

XC21 SERIES UNITS

The XC21 is a high efficiency residential split-system condensing unit, which features a two-stage scroll compressor and R-410A refrigerant. Units are available in 2, 3, 4 and 5 ton sizes. The series is designed for use with an expansion valve only (approved for use with R-410A) in the indoor unit. This manual is divided into sections which discuss the major components, refrigerant system, charging procedure, maintenance and operation sequence.

Information contained in this manual is intended for use by qualified service technicians only. All specifications are subject to change.



⚠ CAUTION
Physical contact with metal edges and corners while applying excessive force or rapid motion can result in personal injury. Be aware of, and use caution when working nearby these areas during installation or while servicing this equipment.

⚠ IMPORTANT
Operating pressures of this R-410A unit are higher than pressures in R-22 units. Always use service equipment rated for R-410A.

⚠ WARNING
Improper installation, adjustment, alteration, service or maintenance can cause property damage, personal injury or loss of life. Installation and service must be performed by a qualified installer or service agency.

⚠ WARNING
 Electric shock hazard. Can cause injury or death. Before attempting to perform any service or maintenance, turn the electrical power to unit OFF at disconnect switch(es). Unit may have multiple power supplies.

⚠ CAUTION
To prevent personal injury, or damage to panels, unit or structure, be sure to observe the following:
While installing or servicing this unit, carefully stow all removed panels out of the way, so that the panels will not cause injury to personnel, nor cause damage to objects or structures nearby, nor will the panels be subjected to damage (e.g., being bent or scratched).
While handling or stowing the panels, consider any weather conditions, especially windy conditions, that may cause panels to be blown around and battered.

TABLE OF CONTENTS

General	1
Specifications / Electrical Data	2
I Application	3
II Unit Components	3
III Refrigerant System	14
IV Charging	15
V Service and Recovery	20
VI Maintenance	20
VII Diagrams and Sequence of Operation	21

SPECIFICATIONS						
General Data	Model No.	XC21-024	XC21-036	XC21-048	XC21-060	
	Nominal Tonnage (kW)	2 (7.0)	3 (10.6)	4 (14.1)	5 (17.6)	
Connections (sweat)	Liquid line (o.d.) - in. (mm)	3/8 (9.5)	3/8 (9.5)	3/8 (9.5)	3/8 (9.5)	
	Suction line (o.d.) - in. (mm)	7/8 (22.2)	7/8 (22.2)	7/8 (22.2)	1-1/8 (28.6)	
Refrigerant	¹ R-410A charge furnished	12 lbs. 0 oz. (5.4 kg)	12 lbs. 5 oz. (5.6 kg)	13 lbs. 0 oz. (5.9 kg)	13 lbs. 0 oz. (5.9 kg)	
Outdoor Coil	Net face area - sq. ft. (m ²)	Outer coil	26.92 (2.50)	26.92 (2.50)	26.92 (2.50)	26.92 (2.50)
		Inner coil	26.07 (2.42)	26.07 (2.42)	26.07 (2.42)	26.07 (2.42)
		Tube diameter - in. (mm)	5/16 (0.52)	5/16 (0.52)	5/16 (0.52)	5/16 (0.52)
		No. of rows	2	2	2	2
		Fins per inch (m)	22 (866)	22 (866)	22 (866)	22 (866)
Outdoor Fan	Diameter - in. (mm)	26 (660)	26 (660)	26 (660)	26 (660)	
	No. of blades	3	3	3	3	
	Motor hp (W)	1/3 (249)	1/3 (249)	1/3 (249)	1/3 (249)	
	Cfm (L/s) 1st stage	2800 (1320)	2800 (1320)	2800 (1320)	2800 (1320)	
		2nd stage	3400 (1605)	3400 (1605)	3400 (1605)	3400 (1605)
	Rpm - 1st stage	700	700	700	700	
		2nd stage	820	820	820	820
	Watts - 1st stage	70	96	150	150	
		2nd stage	105	140	220	220
Shipping Data - lbs. (kg) 1 pkg.		314 (142)	331 (150)	337 (153)	357 (162)	
ELECTRICAL DATA						
	Line voltage data - 60hz	208/230V-1ph	208/230V-1ph	208/230V-1ph	208/230V-1ph	
	³ Maximum overcurrent protection (amps)	25	40	50	60	
	² Minimum circuit ampacity	15.7	23.7	29.3	34.9	
Compressor	Rated load amps	10.3	16.7	21.2	25.7	
	Locked rotor amps	52	82	96	118	
	Power factor	0.98	0.98	0.98	0.98	
	Full load amps	2.8	2.8	2.8	2.8	
OPTIONAL ACCESSORIES - must be ordered extra						
Compressor Hard Start Kit	10J42	•	•			
	81J69			•	•	
Compressor Low Ambient Cut-Off	45F08	•	•	•	•	
Compressor Time-Off Control	47J27	•	•	•	•	
Freezestat	3/8 in. tubing 93G35	•	•	•	•	
	1/2 in. tubing 39H29	•	•	•	•	
	5/8 in. tubing 50A93	•	•	•	•	
Indoor Blower Relay	40K58	•	•	•	•	
Low Ambient Kit	68M04	•	•	•	•	
Mounting Base	69J07	•	•	•	•	
SignatureStat™ Home Comfort Controller	81M27	•	•	•	•	
Refrigerant Line Sets	L15-65-15 L15-65-40	•	•	•		
	L15-65-30 L15-65-50					
	Field Fabricate				•	
Time Delay Relay	58M81	•	•	•	•	

NOTE - Extremes of operating range are plus 10% and minus 5% of line voltage.

¹ Refrigerant charge sufficient for 15 ft. (4.6 m) length of refrigerant lines.

² Refer to National or Canadian Electrical Code manual to determine wire, fuse and disconnect size requirements.

³ HACR type breaker or fuse.

I-APPLICATION

All major components (indoor blower and coil) must be matched according to Lennox recommendations for the compressor to be covered under warranty. Refer to the Engineering Handbook for approved system matchups. A misapplied system will cause erratic operation and can result in early compressor failure.

⚠ CAUTION

In order to avoid injury, take precaution when lifting heavy objects.

II-Unit Components

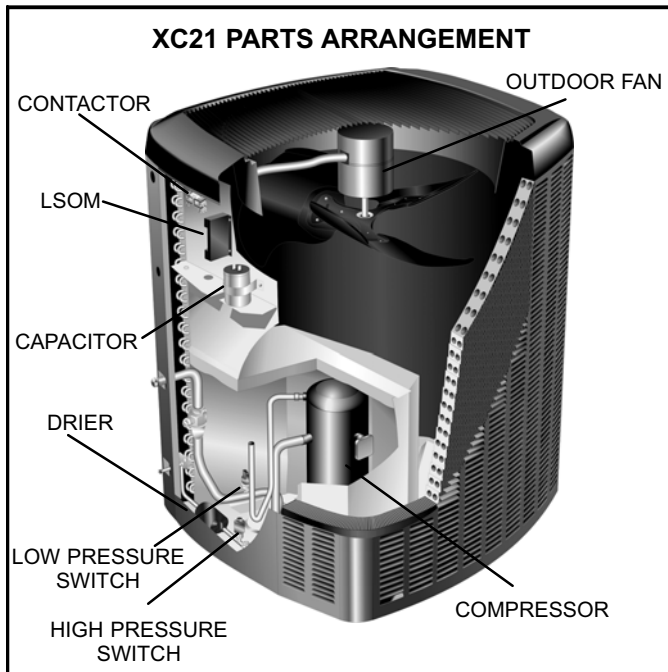

FIGURE 1

Removing/Reinstalling Panels

Open the *access panels* as described in figure 2.

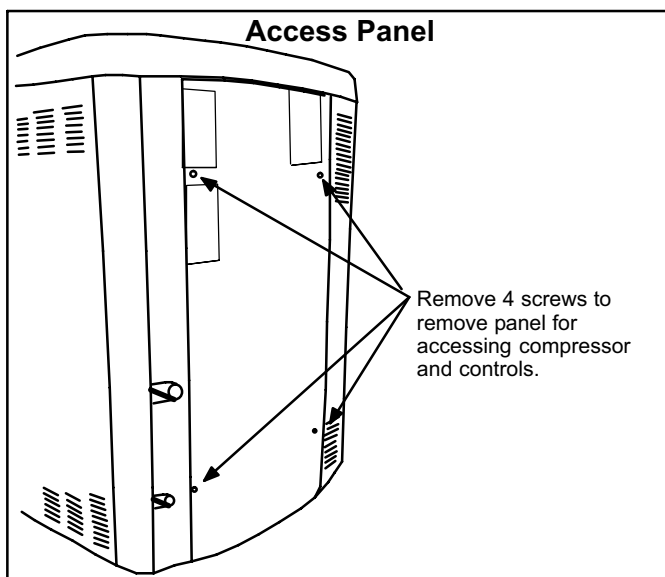

FIGURE 2

Remove the louvered panels as follows:

1. Remove 2 screws, allowing the panel to swing open slightly.
2. **Hold the panel firmly throughout this procedure.** Rotate bottom corner of panel away from hinge corner post until lower 3 tabs clear the slots (see figure 3, Detail B).
3. Move panel down until lip of upper tab clears the top slot in corner post (see figure 3, Detail A).

Removing/Installing Louvered Panels

IMPORTANT! Do not allow panels to hang on unit by top tab. Tab is for alignment and not designed to support weight of panel.

Panel shown slightly rotated to allow top tab to exit (or enter) top slot for removing (or installing) panel.

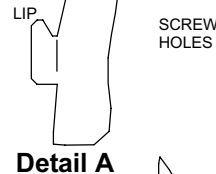

Detail A

LIP

SCREW HOLES

Detail B

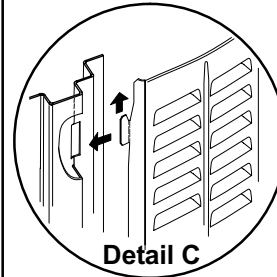

Detail C

ROTATE IN THIS DIRECTION; THEN DOWN TO REMOVE PANEL

MAINTAIN MINIMUM PANEL ANGLE (AS CLOSE TO PARALLEL WITH THE UNIT AS POSSIBLE) WHILE INSTALLING PANEL.

ANGLE MAY BE TOO EXTREME

HOLD DOOR FIRMLY TO THE HINGED SIDE TO MAINTAIN FULLY-ENGAGED TABS

PREFERRED ANGLE FOR INSTALLATION

Detail D

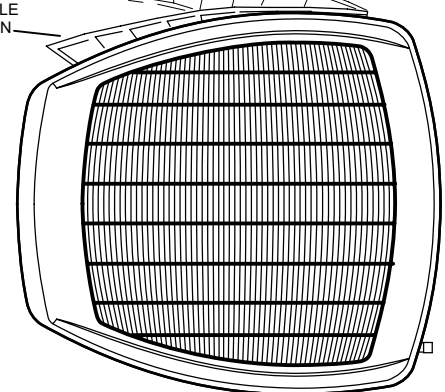

FIGURE 3

**ELECTROSTATIC DISCHARGE (ESD)
Precautions and Procedures**

⚠ CAUTION

Electrostatic discharge can affect electronic components. Take precautions during unit installation and service to protect the unit's electronic controls. Precautions will help to avoid control exposure to electrostatic discharge by putting the unit, the control and the technician at the same electrostatic potential. Neutralize electrostatic charge by touching hand and all tools on an unpainted unit surface before performing any service procedure.

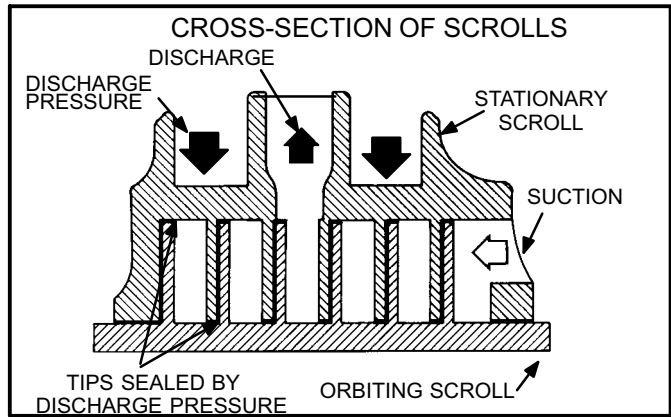

FIGURE 6

The counterclockwise orbiting scroll draws gas into the outer crescent shaped gas pocket created by the two scrolls (figure 7- 1). The centrifugal action of the orbiting scroll seals off the flanks of the scrolls (figure 7- 2). As the orbiting motion continues, the gas is forced toward the center of the scroll and the gas pocket becomes compressed (figure 7-3). When the compressed gas reaches the center, it is discharged vertically into a chamber and discharge port in the top of the compressor. The discharge pressure forcing down on the top scroll helps seal off the upper and lower edges (tips) of the scrolls (figure 6). During a single orbit, several pockets of gas are compressed simultaneously providing smooth continuous compression.

The scroll compressor is tolerant to the effects of liquid return. If liquid enters the scrolls, the orbiting scroll is allowed to separate from the stationary scroll. The liquid is worked toward the center of the scroll and is discharged. If the compressor is replaced, conventional Lennox cleanup practices must be used.

Due to its efficiency, the scroll compressor is capable of drawing a much deeper vacuum than reciprocating compressors. Deep vacuum operation can cause internal fusite arcing resulting in damaged internal parts and will result in compressor failure. This type of damage can be detected and will result in denial of warranty claims. The scroll compressor can be used to pump down refrigerant as long as the pressure is not reduced below 7 psig.

NOTE - During operation, the head of a scroll compressor may be hot since it is in constant contact with discharge gas.

The scroll compressors in all XC21 model units are designed for use with R-410A refrigerant and operation at high pressures. Compressors are shipped from the factory with 3MA (32MMMA) P.O.E. oil. See electrical section in this manual for compressor specifications.

A-Two-Stage Scroll Compressor (B1)

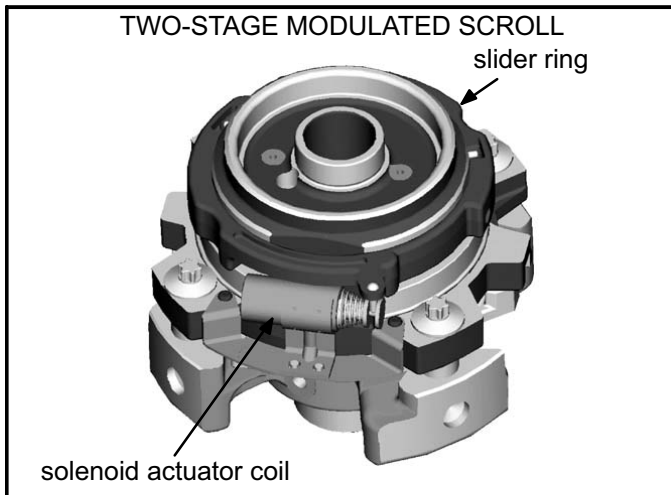

FIGURE 4

The scroll compressor design is simple, efficient and requires few moving parts. A cutaway diagram of the scroll compressor is shown in figure 1. The scrolls are located in the top of the compressor can and the motor is located just below. The oil level is immediately below the motor.

The scroll is a simple compression concept centered around the unique spiral shape of the scroll and its inherent properties. Figure 5 shows the basic scroll form. Two identical scrolls are mated together forming concentric spiral shapes (figure 6). One scroll remains stationary, while the other is allowed to "orbit" (figure 7). Note that the orbiting scroll does not rotate or turn but merely "orbits" the stationary scroll.

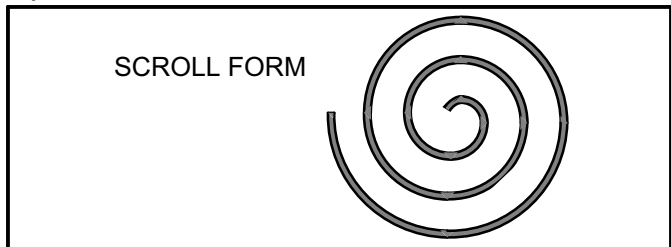

FIGURE 5

TWO-STAGE OPERATION

The two-stage scroll compressor operates like any standard scroll compressor with the exception the two-stage compressor modulates between first stage (low capacity approximately 67%) and second stage (high capacity). Modulation occurs when gas is bypassed through bypass ports (figure 8 bypass ports open) in the first suction pocket. This bypassing of gas allows the compressor to operate on first stage (low capacity) if thermostat demand allows. Indoor thermostat setting will determine first or second stage operation. The compressor will operate on first-stage until demand is satisfied or the indoor temperature reaches the thermostat set point calling for second-stage.

Second-stage (high capacity) is achieved by blocking the bypass ports (figure 8 bypass ports closed) with a slider ring. The slider ring begins in the open position and is controlled by a **24VDC** internal solenoid. On a Y2 call the internal solenoid closes the slider ring, blocking the bypass ports and bringing the compressor to high capacity. Two-stage modulation can occur during a single thermostat demand as the motor runs continuously while the compressor modulates from first-stage to second-stage.

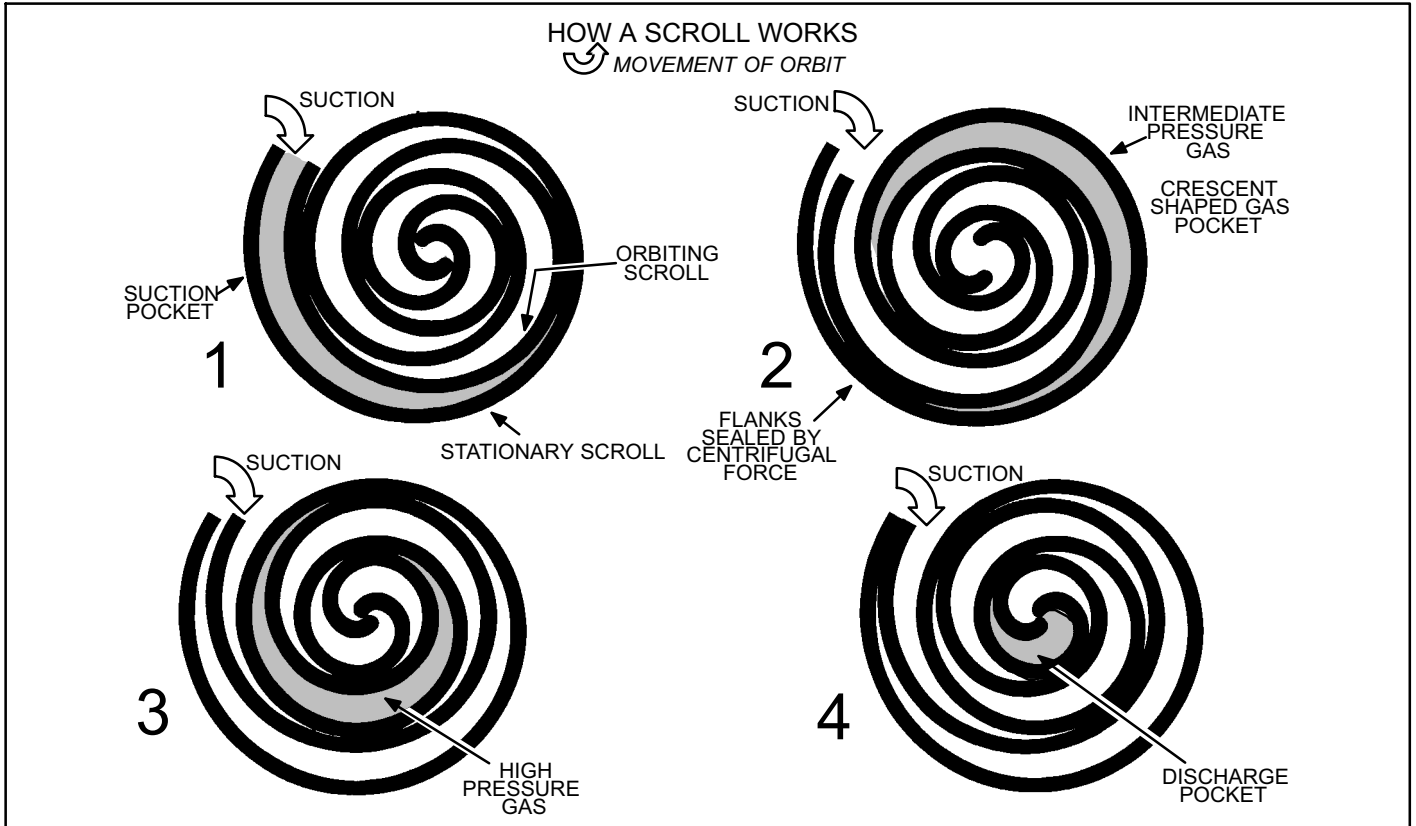

FIGURE 7

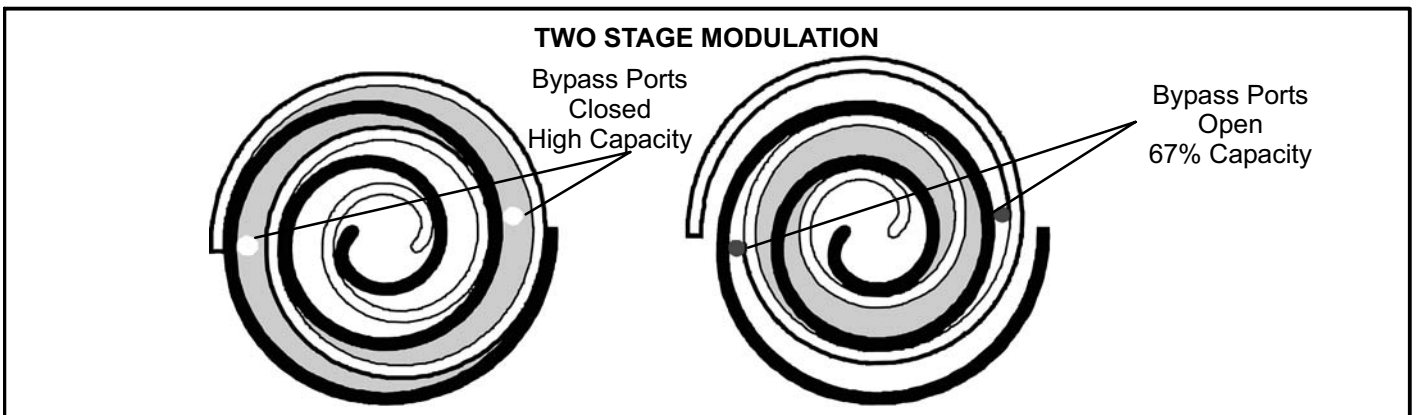

FIGURE 8

TABLE 1

Unit Readings	Cooling Operation		
	Y1 - 1st-Stage	Expected Results	Y2 - 2nd-Stage
Compressor			
Voltage		Same	
Amperage		Higher	
Condenser Fan motor			
Amperage		Same or Higher	
Temperature			
Ambient		Same	
Outdoor Coil Discharge Air		Higher	
Compressor Discharge Line		Higher	
Indoor Return Air		Same	
Indoor Coil Discharge Air		Lower	
Pressures			
Suction (Vapor)		Lower	
Liquid		Higher	

INTERNAL SOLENOID (L34)

The internal unloader solenoid controls the two-stage operation of the compressor by shifting a slide ring mechanism to open (low capacity) or close (high capacity), two by-pass ports in the first compression pocket of the scrolls in the compressor. The internal solenoid is activated by a **24 volt direct current solenoid coil**. The internal wires from the solenoid in the compressor are routed to a 2 pin fuse connection on the side of the compressor shell. The external electrical connection is made to the compressor with a molded plug assembly. The molded plug receives 24 volt DC power from the LSOM II.

If it is suspected the unloader is not operating properly, check the following

⚠ IMPORTANT

This performance check is ONLY valid on systems that have clean indoor and outdoor coils, proper air-flow over coils, and correct system refrigerant charge. All components in the system must be functioning proper to correctly perform compressor modulation operational check. (Accurate measurements are critical to this test as indoor system loading and outdoor ambient can affect variations between low and high capacity readings).

STEP 1 Confirm low to high capacity compressor operation

Tools required

- Refrigeration gauge set
- Digital volt/amp meter
- Electronic temperature thermometer

On-off toggle switch

Procedure

1. Turn main power "OFF" to outdoor unit.
2. Adjust room thermostat set point above (heating operation on heat pump) or below (cooling operation) the room temperature 5°F.
3. Remove control access panel. Install refrigeration gauges on unit. Attach the amp meter to the common (black wire) wire of the compressor harness. Attach thermometer to discharge line as close as possible to the compressor.
4. Turn toggle switch "OFF" and install switch in series with Y2 wire from room thermostat.
5. Cycle main power "ON."
6. Allow pressures and temperatures to stabilize before taking any measured reading (may take up to 10 minutes).

NOTE - Block outdoor coil to maintain a minimum of 375 psig during testing).

7. Record all of the readings for the Y1 demand on table 1.
8. Close switch to energize Y2 demand.
9. Allow pressures and temperatures to stabilize before taking any measured reading (this may take up to 10 minutes).
10. Record all of the readings of Y2 demand on table 1.

NOTE - On new installations or installations that have shut down for an extended period of time, if the compressor does not cycle from low stage to high stage on the first attempt, it may be necessary to recycle the compressor back down to low stage and back up to high stage a few times in order to get the bypass seals to properly seat

Compare Y1 readings with Y2 readings in table 1. Some readings should be higher, lower or the same. If the readings follow what table 1 specifies, the compressor is operating and shifting to high capacity as designed. If the readings do not follow what table 1 specifies, continue to step 2 to determine if problem is with external solenoid plug power.

STEP 2 Confirm DC voltage output on compressor solenoid plug

1. Shut power off to the outdoor unit.
2. Insert lead wires from voltmeter into back of the red and black wire plug jack that feeds power to compressor solenoid coil. Set voltmeter to DC volt scale to read DC voltage output from LSOM II plug. See figure 9.

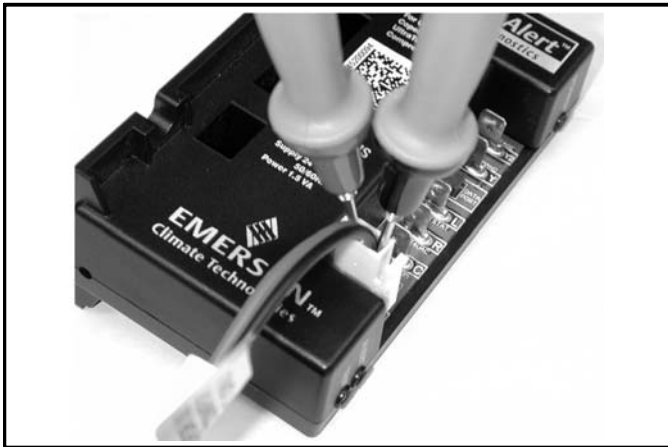

FIGURE 9

3. Apply a Y1 and Y2 demand from the indoor thermostat to the LSOM II.
4. Turn power back on to unit.
5. Compressor should cycle “ON” when Y1 is calling.
6. With Y2 calling, 5 seconds after compressor cycles “ON”, LSOM II will output 24 volt DC signal to the compressor solenoid plug. Once the solenoid has pulled in, the LSOM II will reduce the DC voltage to a pulsating 6 to 18 volt DC output to the solenoid to allow the solenoid to remain energized.

⚠ IMPORTANT
 When checking compressor for two-stage operation, always cycle Y1 to Y2 from terminals on the LSOMII or room thermostat connections. **DO NOT** cycle second stage (Y2) of compressor by unplugging the 24VDC solenoid LSOM II end of plug. The LSOM II will only output a 6 to 18VDC signal which will be insufficient voltage to pull the solenoid coil in for second stage.

If compressor solenoid is still not shifting to high capacity, this check will verify that DC power is being fed from the LSOM II.

1. Shut power off to unit (main and low voltage)
2. Unplug the 2 pin solenoid plug from the fusite connection on the compressor and the plug end from the LSOM II.
3. Using an OHM meter, check for continuity on the plug harness wire ends (red to red, black to black). Wires should have continuity between same colors and no continuity between opposite color wires.

If the above checks verify that the solenoid plug is providing power to cycle into high capacity operation, continue to step 3 to determine if problem is with solenoid coil in compressor

STEP 3 Confirm internal unloader solenoid has proper resistance

1. Shut all power off to unit (main and low voltage)
2. Unplug the molded plug from the compressor solenoid 2-pin fusite.
3. Using a volt meter set on the 200 ohm scale

Replace the Compressor under these conditions:

Bad Solenoid

- a. Measure the resistance at the 2-pin fusite. The resistance should be 32 to 60 ohms depending on compressor temperature. If no resistance, replace compressor.
- b. Measure the resistance from each fusite pin to ground. There should **not be** continuity to ground. If solenoid coil is grounded, replace compressor.

Good Solenoid

- a. Seals not shifting, replace compressor
- b. Slider ring not shifting, replace compressor.

B-Capacitor (C5)

The compressor uses a permanent split capacitor (see unit wiring diagram). The capacitor is located inside the unit control box. Ratings are on capacitor side.

C-High Pressure Switch (S4)

⚠ IMPORTANT
 Pressure switch settings for R-410A refrigerant will be significantly higher than units with R-22.

A manual-reset, single-pole/single-throw high pressure switch is located in the liquid line. The switch shuts off the compressor by de-energizing K1 when liquid line pressure rises above the factory setting. The switch is normally closed and is permanently adjusted to trip (open) at 590 ± 10 psi. See figure 1 for switch location.

D-Low Pressure Switch (S87)

All XC21 units are equipped with an auto-reset, single-pole/single-throw low pressure switch is located in the vapor line. This switch shuts off the compressor by de-energizing K1 when vapor line pressure drops below the factory setting. The switch is closed during normal operating pressure conditions and is permanently adjusted to trip (open) at 40 ± 5 psi. The switch automatically resets when vapor line pressure rises above 90 ± 5 psi. See figure 1 for switch location.

E-Contactor (K1)

The compressor is energized by a contactor located in the control box. XC21 units are single-phase with single-pole contactors. See figure 1 for location.

⚠ DANGER



Shock Hazard
Remove all power at disconnect before removing access panel. XC21 units use single-pole contactors. Potential exists for electrical shock resulting in injury or death. Line voltage exists at all components (even when unit is not in operation).

F-Crankcase Heater (HR1) and Thermostat

The compressor in the unit is equipped with a 70 watt, belly band type crankcase heater. HR1 prevents liquid from accumulating in the compressor. HR1 is controlled by a thermostat located on the liquid line. When liquid line temperature drops below 50° F the thermostat closes energizing HR1. The thermostat will open, de-energizing HR1 once liquid line temperature reaches 70° F .

G-Condenser Fan with Variable Speed Motor (B4)

The condenser fan motor (figure 10) used in all units is a three-phase, electronically controlled d.c. brushless motor (controller converts single phase a.c. to three phase d.c.), with a permanent-magnet-type rotor, manufactured by GE. Because this motor has a permanent magnet rotor it does not need brushes like conventional D.C. motors. The motors consist of a control module and motor . Internal components are

shown in figure 11. The stator windings are split into three poles which are electrically connected to the controller. This arrangement allows motor windings to be turned on and off in sequence by the controller.

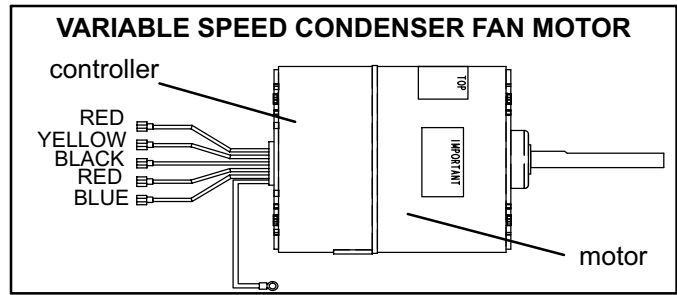

FIGURE 10

The controller is primarily an a.c. to d.c. converter. Converted d.c. power is used to drive the motor. The controller contains a microprocessor which monitors varying conditions inside the motor (such as motor workload).

The controller uses sensing devices to know what position the rotor is in at any given time. By sensing the position of the rotor and then switching the motor windings on and off in sequence, the rotor shaft turns the blower.

Internal Operation

The condenser fan motor is a variable speed motor with RPM settings at 700 (Y1) and 820 (Y2). The variation in speed is accomplished each time the controller switches a stator winding (figure 11) on and off, it is called a "pulse." The length of time each pulse stays on is called the "pulse width." By varying the pulse width the controller varies motor speed (called "pulse-width modulation"). This allows for precise control of motor speed and allows the motor to compensate for varying load conditions as sensed by the controller. In this case, the controller monitors the static workload on the motor and varies motor rpm in order to maintain constant airflow (cfm).

Motor rpm is continually adjusted internally to maintain constant static pressure against the fan blade. The controller monitors the static work load on the motor and motor amp-draw to determine the amount of rpm adjustment. Blower rpm may be adjusted any amount in order to maintain a constant cfm. The amount of adjustment is determined by the incremental taps which are used and the amount of motor loading sensed internally. The motor constantly adjusts rpm to maintain a specified cfm.

Initial Power Up

When line voltage is applied to the motor, there will be a large inrush of power lasting less than 1/4 second. This inrush charges a bank of DC filter capacitors inside the controller. If the disconnect switch is bounced when the disconnect is closed, the disconnect contacts may become welded. Try not to bounce the disconnect switch when applying power to the unit.

The DC filter capacitors inside the controller are connected electrically to the speed tap wires. The capacitors take approximately 5 minutes to discharge when the disconnect is opened. For this reason it is necessary to wait at least 5 minutes after turning off power to the unit before attempting to change speed taps.

DANGER

Disconnect power from unit and wait at least five minutes to allow capacitors to discharge before attempting to adjust motor speed tap settings. Failure to wait may cause personal injury or death.

Motor Start-Up

At start-up, the motor may gently rock back and forth for a moment. This is normal. During this time the electronic controller is determining the exact position of the rotor. Once the motor begins turning, the controller slowly eases the motor up to speed (this is called "soft-start"). The motor may take as long as 10-15 seconds to reach full speed. If the motor does not reach 200 rpm within 13 seconds, the motor shuts down. Then the motor will immediately attempt a restart. The shutdown feature provides protection in case of a frozen bearing or blocked fan blade. The motor may attempt to start eight times. If the motor does not start after the eighth try, the controller locks out. Reset controller by momentarily turning off main power to unit.

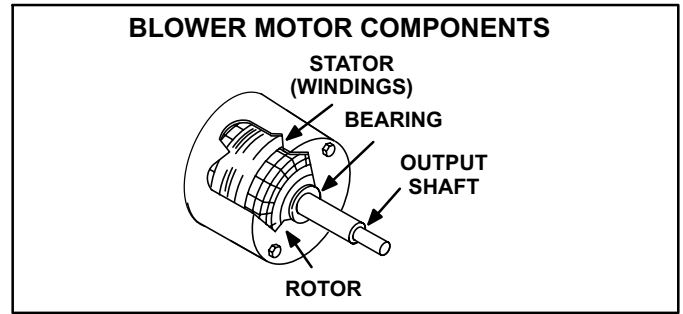

FIGURE 11

Troubleshooting

If first or second stage thermostat call for cool is present and the variable speed condenser fan motor does not energize, check voltage at the breaker box. If voltage is present do the following.

- 1- Check for 240 volts between the fan motor RED wires.
- 2- Initiate a first stage call for cool. Check for 24 volts between the fan motor YELLOW wire and fan motor BLACK wire.
- 3- Initiate a second stage call for cool. Check for 24 volts between the fan motor YELLOW wire and fan motor BLACK wire, then check for 24 volts between the fan motor BLUE wire and fan motor BLACK.

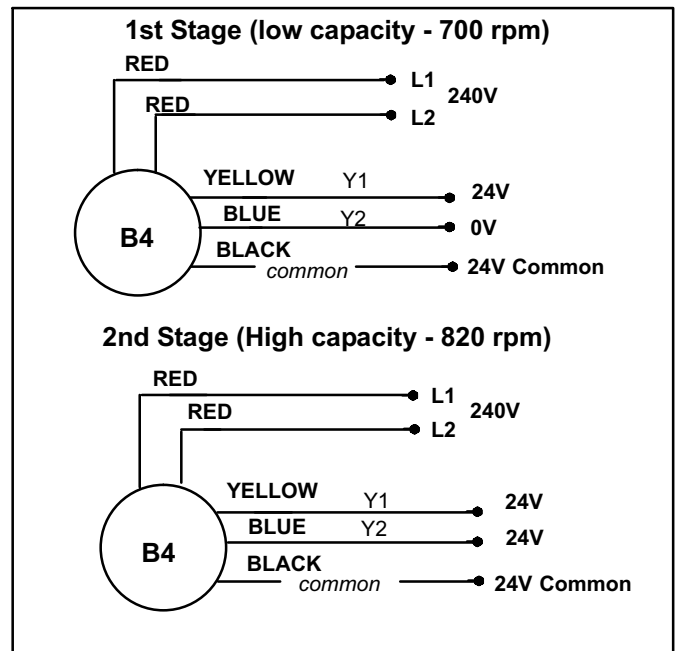

FIGURE 12

Replacement

See figure 13 if condenser fan motor replacement is necessary.

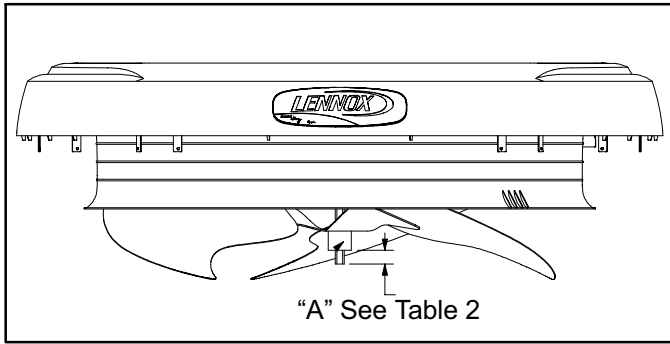

FIGURE 13

TABLE 2

XC21 UNIT	"A" DIM. \pm 1/8"
-024, -036	3/4"
-048, -060	Flush

H-Drier

A filter drier designed for all XC21 model units is factory installed in the liquid line. The filter drier is designed to remove moisture and foreign matter, which can lead to compressor failure.

Moisture and / or Acid Check

Because POE oils absorb moisture, the dryness of the system must be verified any time the refrigerant system is exposed to open air. A compressor oil sample must be taken to determine if excessive moisture has been introduced to the oil. Table 3 lists kits available from Lennox to check POE oils.

If oil sample taken from a system that has been exposed to open air does not test in the dry color range, the filter drier **MUST** be replaced.

! IMPORTANT

Replacement filter drier **MUST be approved for R-410A refrigerant and POE application.**

Foreign Matter Check

It is recommended that a liquid line filter drier be replaced when the pressure drop across the filter drier is greater than 4 psig.

TABLE 3

KIT	CONTENTS	TUBE SHELF LIFE
10N46 - Refrigerant Analysis	Checkmate-RT700	
10N45 - Acid Test Tubes	Checkmate-RT750A (three pack)	2 - 3 years @ room temperature. 3+ years refrigerated
10N44 - Moisture Test Tubes	Checkmate - RT751 Tubes (three pack)	6 - 12 months @ room temperature. 2 years refrigerated
74N40 - Easy Oil Test Tubes	Checkmate - RT752C Tubes (three pack)	2 - 3 years @ room temperature. 3+ years refrigerated
74N39 - Acid Test Kit	Sporlan One Shot - TA-1	

MEASURING FILTER DRIER PRESSURE DROP

- 1- Shut off power to unit.
- 2- Remove high pressure switch from fitting next to filter drier.
(A schrader core is located under the high pressure switch).
- 3- Install high pressure gauge hose onto high pressure switch fitting.
- 4- Turn power on to unit and turn room thermostat to call for cooling.
- 5- Record pressure reading on gauge.
- 6- Remove hose from high pressure fitting and install on liquid line valve.
- 7- Read liquid line valve pressure.
- 8- High pressure fitting pressure - liquid line valve pressure = filter drier pressure drop.
- 9- If pressure drop is greater than 4 psig replace filter drier. See figure 15.
- 10- Re-install high pressure switch.

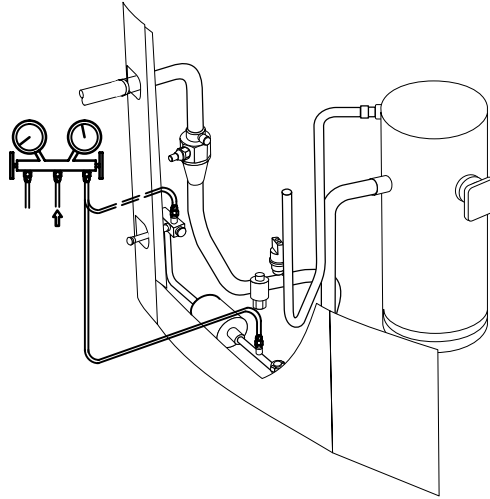

FIGURE 14

REPLACING FILTER DRIER

- 1- Recover all refrigerant from unit.
- 2- Remove original filter drier.
- 3- Install new filter drier in existing location or alternate location as shown. *Proper brazing procedures should be followed.*
- 4- Evacuate system. See section IV- part B-.
- 5- Recharge system. See section IV- part C-.

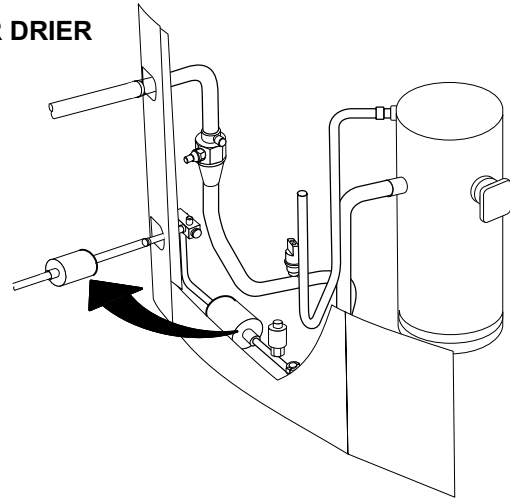

FIGURE 15

I-Lennox System Operation Monitor (A132)

The Lennox system operation monitor (LSOM) is a 24 volt powered module, (see diagnostic module A132 on wiring diagram and figure 16) wired directly to the indoor unit. The LSOM is located in the control box and is used to troubleshoot problems in the system. The module has three LED's for troubleshooting: GREEN indicates power status, YELLOW indicates an abnormal condition and RED indicates thermostat demand, but compressor not operating. See table 4 for troubleshooting codes.

The diagnostic indicator detects the most common fault conditions in the air conditioning system. When an abnormal condition is detected, the module communicates the specific condition through its ALERT and TRIP lights. The module is capable of detecting both mechanical and electrical system problems. See figure 16 for the system operation monitor.

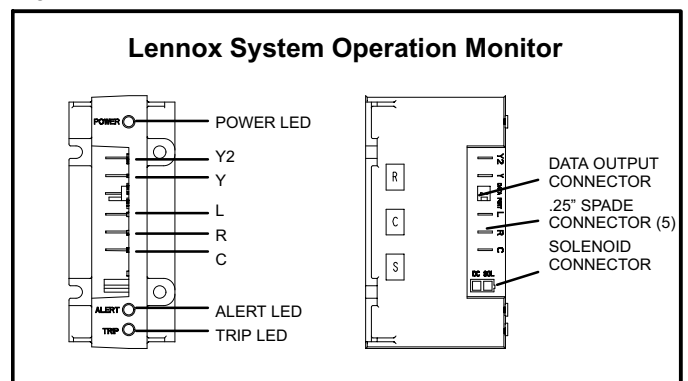

FIGURE 16

IMPORTANT

This monitor does not provide safety protection. The monitor is a monitoring device only and cannot control or shut down other devices.

LED Functions

Alert LED (green) - Indicates voltage within the range of 19-28VAC is present at the system monitor connections.

Alert LED (yellow) - communicates an abnormal system condition through a unique Flash Code— the alert LED flashes a number of times consecutively; then pauses; then repeats the process. This consecutive flashing correlates to a particular abnormal condition.

Trip LED (red) - indicates there is a demand signal from the thermostat but no current to the compressor is detected by the module.

Flash code number - corresponds to a number of LED flashes, followed by a pause, and then repeated.

Trip & Alert LEDs flashing simultaneously - indicates that the control circuit voltage is too low for operation.

Reset ALERT flash code by removing 24VAC power from monitor. Last ALERT flash code will display for 1 minute after monitor is powered on.

Thermostat Second-Stage Cooling

The Lennox system operation monitor (LSOM) requires a two-stage room thermostat to operate properly.

Y2 room thermostat connection—While the compressor is not running, LSOM will not power the solenoid, regardless of the state of Y2. If alert codes 1 or 9 (see table 4) appear while the compressor is running, LSOM will turn off the solenoid to prevent solenoid damage from overheating conditions.

L terminal connection—The L connection is used to communicate alert codes to the room thermostat. On selected Lennox SignatureStat™ thermostats, a blinking “check” LED will display on the room thermostat and on select White-Rodgers room thermostats, an icon on the display will flash. Either will flash at the same rate as the LSOM yellow alert LED.

NOTE - ROOM THERMOSTAT WITH SERVICE OR CHECK LIGHT FEATURE - The room thermostat may blink the “Check” or “Service” LED or it may come on solid. Confirm fault by observing and interpreting the code from the LSOM yellow alert LED at the unit.

Y2 DC Solenoid Connector (DC SOL)—The 24VDC solenoid, which is internal to the compressor, will not operate properly if 24VAC is applied to the compressor solenoid terminals. A voltmeter attached to the DC SOL output will measure 4-18 VDC when the solenoid is energized.

Installation verification-LSOM—To verify correct LSOM installation, two functional tests can be performed. Disconnect power from the compressor and force a thermostat call for cooling. The red trip LED should turn on indicating a compressor trip as long as 24VAC is measured at the Y terminal. If the red LED does not function as described, refer to table 4 to verify the wiring. Disconnect power from the compressor and 24VAC power from LSOM. Remove the wire from the Y terminal of LSOM and reapply power to the compressor, allowing the compressor to run. The yellow alert LED will begin flashing a code 8 indicating a welded contactor. Disconnect power from the compressor and 24VAC power from the LSOM. While the LSOM is off, reattach the wire to the Y terminal. Reapply power to the compressor and 24VAC power to the LSOM; the yellow alert LED will flash the previous code 8 for one minute and then turn off. If the yellow LED does not function as described, refer to table 4 to verify the wiring.

Resetting alert codes—Alert codes can be reset manually or automatically:

Manual reset: Cycle the 24VAC power to LSOM off and on.

Automatic reset: After an alert is detected, the LSOM continues to monitor the compressor and system. When/if conditions return to normal, the alert code is turned off automatically.

TABLE 4

Lennox System Operation Monitor LED Troubleshooting Codes		
Status LED Condition	Status LED Description	Status LED Troubleshooting Information
Green "Power" LED ON	Module has power	24VAC control power is present at the module terminal.
Green "Power" LED OFF	Module not powering up	Determine/verify that both R and C module terminals are connected and voltage is present between both terminals.
Red "Trip" LED ON	System and compressor check out OK Thermostat demand signal Y1 is present, but compressor not running	<ol style="list-style-type: none"> 1 Verify Y terminal is connected to 24VAC at contactor coil. 2 Verify voltage at contactor coil falls below 0.5VAC when off. 3 Verify 24VAC is present across Y and C when thermostat demand signal is present; if not present, R and C wires are reversed. 4 Compressor protector is open. 5 Outdoor unit power disconnect is open. 6 Compressor circuit breaker or fuse(s) is open. 7 Broken wire or connector is not making contact. 8 Low pressure switch open if present in the system. 9 Compressor contactor has failed to close.
Red "Trip" & Yellow "Alert" LEDs Flashing	Simultaneous flashing.	Indicates that the control circuit voltage is too low for operation.
Yellow "Alert" Flash Code 1*	Long Run Time - Compressor is running extremely long run cycles	<ol style="list-style-type: none"> 1 Low refrigerant charge. 2 Evaporator blower is not running. 3 Evaporator coil is frozen. 4 Faulty metering device. 5 Condenser coil is dirty. 6 Liquid line restriction (filter drier blocked if present). 7 Thermostat is malfunctioning.
Yellow "Alert" Flash Code 2*	System Pressure Trip - Discharge or suction pressure out of limits or compressor overloaded	<ol style="list-style-type: none"> 1 High head pressure. 2 Condenser coil poor air circulation (dirty, blocked, damaged). 3 Condenser fan is not running. 4 Return air duct has substantial leakage. 5 If low pressure switch is present, see Flash Code 1 information.
Yellow "Alert" Flash Code 3*	Short Cycling - Compressor is running only briefly	<ol style="list-style-type: none"> 1 Thermostat demand signal is intermittent. 2 Time delay relay or control board is defective. 3 If high pressure switch is present, see Flash Code 2 information. 4 If low pressure switch is present, see Flash Code 1 information.
Yellow "Alert" Flash Code 4*	Locked Rotor	<ol style="list-style-type: none"> 1 Run capacitor has failed. 2 Low line voltage (contact utility if voltage at disconnect is low). 3 Excessive liquid refrigerant in the compressor. 4 Compressor bearings are seized.
Yellow "Alert" Flash Code 5*	Open Circuit	<ol style="list-style-type: none"> 1 Outdoor unit power disconnect is open. 2 Unit circuit breaker or fuse(s) is open. 3 Unit contactor has failed to close. 4 High pressure switch is open and requires manual reset. 5 Open circuit in compressor supply wiring or connections. 6 Unusually long compressor protector reset time due to extreme ambient temperature. 7 Compressor windings are damaged.
Yellow "Alert" Flash Code 6*	Open Start Circuit - Current only in run circuit	<ol style="list-style-type: none"> 1 Run capacitor has failed. 2 Open circuit in compressor start wiring or connections. 3 Compressor start winding is damaged.
Yellow "Alert" Flash Code 7*	Open Run Circuit - Current only in start circuit	<ol style="list-style-type: none"> 1 Open circuit in compressor start wiring or connections. 2 Compressor start winding is damaged.
Yellow "Alert" Flash Code 8*	Welded Contactor - Compressor always runs	<ol style="list-style-type: none"> 1 Compressor contactor failed to open. 2 Thermostat demand signal not connected to module.
Yellow "Alert" Flash Code 9*	Low Voltage - Control circuit <17VAC	<ol style="list-style-type: none"> 1 Control circuit transformer is overloaded. 2 Low line voltage (contact utility if voltage at disconnect is low).

*Flash code number corresponds to a number of LED flashes, followed by a pause, and then repeated. Reset ALERT flash code by removing 24VAC power from monitor; last code will display for 1 minute after monitor is powered on.

III-REFRIGERANT SYSTEM

⚠ WARNING

R-410A refrigerant can be harmful if it is inhaled. R-410A refrigerant must be used and recovered responsibly.

Failure to follow this warning may result in personal injury or death.

A-Plumbing

Field refrigerant piping consists of liquid and vapor lines from the outdoor unit (sweat connections) to the indoor coil (flare or sweat connections). Use Lennox L15 (sweat, non-flare) series line sets as shown in table 5 or use field-fabricated refrigerant lines. Valve sizes are also listed in table 5.

TABLE 5

XC21	Valve Size Connections		Recommended Line Set		
	Liquid Line	Vapor Line	Liquid Line	Vapor Line	L15 Line Sets
-024, -036	3/8 in. (10 mm)	7/8 in. (22 mm)	3/8 in. (10 mm)	7/8 in. (22 mm)	L15-65 15 ft. - 50 ft. (4.6 m - 15 m)
-048	3/8 in. (10 mm)	7/8 in. (22 mm)	3/8 in. (10 mm)	7/8 in. (22 mm)	L15-65 15 ft. - 50 ft. (4.6 m - 15 m)
-060	3/8 in. (10 mm)	1-1/8 in. (29 mm)	3/8 in. (10 mm)	1-1/8 in. (29 mm)	Field Fabricated

NOTE - When installing refrigerant lines, refer to Lennox Technical Support Product Applications for assistance. In addition, be sure to consider the following points:

Select line set diameters from table 5 to ensure that oil returns to the compressor.

Units are designed for line sets of up to fifty feet (15 m); for longer line sets, consult piping guidelines.

Size vertical vapor riser to maintain minimum velocity at minimum capacity.

B-Service Valves

The liquid line and vapor line service valves (figures 17 and 18) and gauge ports are used for leak testing, evacuating, charging and checking charge. See table 6 for torque requirements.

Each valve is equipped with a service port which has a factory-installed Schrader valve. A service port cap protects the Schrader valve from contamination and serves as the primary leak seal.

TABLE 6

Part	Recommended Torque	
Service valve cap	8 ft.- lb.	11 NM
Sheet metal screws	16 in.- lb.	2 NM
Machine screws #10	28 in.- lb.	3 NM
Compressor bolts	90 in.- lb.	10 NM
Gauge port seal cap	8 ft.- lb.	11 NM

To Access Schrader Port:

- 1 - Remove service port cap with an adjustable wrench.
- 2 - Connect gauge to the service port.
- 3 - When testing is complete, replace service port cap. Tighten finger tight, then an additional 1/6 turn.

To Open Service Valve:

- 1 - Remove the stem cap with an adjustable wrench.
- 2 - Use a service wrench with a hex-head extension to back the stem out counterclockwise as far as it will go.
NOTE - Use a 3/16" hex head extension for 3/8" line sizes.
- 3 - Replace the stem cap. Tighten finger tight, then tighten an additional 1/6 turn.

To Close Service Valve:

- 1 - Remove the stem cap with an adjustable wrench.
- 2 - Use a service wrench with a hex-head extension to turn the stem clockwise to seat the valve. Tighten the stem firmly.
NOTE - Use a 3/16" hex head extension for 3/8" line sizes.
- 3 - Replace the stem cap. Tighten finger tight, then tighten an additional 1/6 turn.

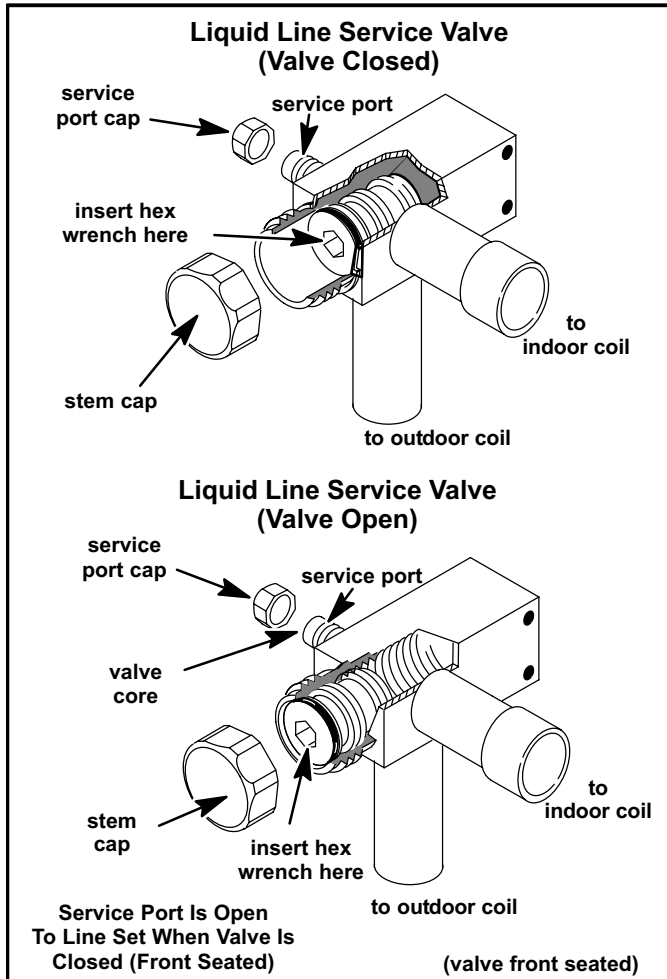

FIGURE 17

Vapor Line Ball Valve – All Units

Vapor line service valves function the same way as the other valves, the difference is in the construction. These valves are not rebuildable. If a valve has failed, you must replace it. A ball valve is illustrated in figure 18.

The ball valve is equipped with a service port with a factory-installed Schrader valve. A service port cap protects the Schrader valve from contamination and assures a leak-free seal.

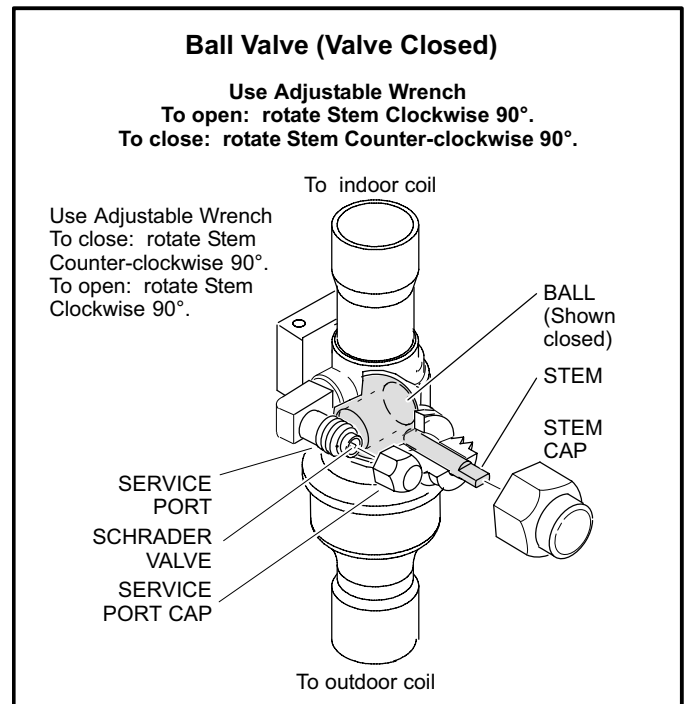

FIGURE 18

IV-CHARGING

▲ IMPORTANT

The Clean Air Act of 1990 bans the intentional venting of (CFC's and HFC's) as of July 1, 1992. Approved methods of recovery, recycling or reclaiming must be followed. Fines and/or incarceration may be levied for noncompliance.

Units are factory charged with the amount of R-410A refrigerant indicated on the unit rating plate. This charge is based on a matching indoor coil and outdoor coil with 15 ft. (4.6m) line set. For varying lengths of line set, refer to table 7 for refrigerant charge adjustment.

TABLE 7

Liquid Line Set Diameter	Oz. per 5 ft. (grams per 1.5m) adjust from 15 ft. (4.6 m) line set*
3/8 in. (9.5 mm)	3 ounces per 5 feet (85 g per 1.5 m)

**If line length is greater than 15 ft. (4.6 m), add this amount. If line length is less than 15 ft. (4.6 m), subtract this amount.*

A-Leak Testing

After the line set has been connected to the indoor and outdoor units, check the line set connections and indoor unit for leaks.

⚠ WARNING



Fire, Explosion and Personal Safety Hazard.
Failure to follow this warning could result in damage, personal injury or death.
Never use oxygen to pressurize or purge refrigeration lines. Oxygen, when exposed to a spark or open flame, can cause damage by fire and / or an explosion, that can result in personal injury or death.

⚠ WARNING



Danger of explosion!
When using a high pressure gas such as dry nitrogen to pressurize a refrigerant or air conditioning system, use a regulator that can control the pressure down to 1 or 2 psig (6.9 to 13.8 kPa).

Using an Electronic Leak Detector

- 1 - Connect the high pressure hose of the manifold gauge set to the vapor valve service port. (*Normally, the high pressure hose is connected to the liquid line port, however, connecting it to the vapor port helps to protect the manifold gauge set from damage caused by high pressure.*)
- 2 - With both manifold valves closed, connect the cylinder of R-410A refrigerant. Open the valve on the R-410A cylinder (vapor only).
- 3 - Open the high pressure side of the manifold to allow R-410A into the line set and indoor unit. Weigh in a trace amount of R-410A. [*A trace amount is a maximum of 2 ounces (57 g) refrigerant or 3 pounds (31 kPa) pressure.*] Close the valve on the R-410A cylinder and the valve on the high pressure side of the manifold gauge set. Disconnect R-410A cylinder.
- 4 - Connect a cylinder of nitrogen with a pressure regulating valve to the center port of the manifold gauge set.
- 5 - Adjust nitrogen pressure to 150 psig (1034 kPa). Open the valve on the high side of the manifold gauge set in order to pressurize the line set and the indoor coil.
- 6 - After a few minutes, open a refrigerant port to check that an adequate amount of refrigerant has been added for detection (refrigerant requirements will vary with line lengths). Check all joints for leaks. Purge nitrogen and R-410A mixture. Correct any leaks and re-check.

B-Evacuating the System

Evacuating the system of noncondensables is critical for proper operation of the unit. Noncondensables are defined as any gas that will not condense under temperatures and pressures present during operation of an air conditioning system. Noncondensables and water vapor combine with refrigerant to produce substances that corrode copper piping and compressor parts.

NOTE - This evacuation process is adequate for a new installation with clean and dry lines. If excessive moisture is present, the evacuation process may be required more than once.

⚠ IMPORTANT

Use a thermocouple or thermistor electronic vacuum gauge that is calibrated in microns. Use an instrument that reads from 50 microns to at least 10,000 microns.

- 1 - Connect manifold gauge set to the service valve ports:
 - low pressure gauge to *vapor* line service valve
 - high pressure gauge to *liquid* line service valve
- 2 - Connect micron gauge.
- 3 - Connect the vacuum pump (with vacuum gauge) to the center port of the manifold gauge set.
- 4 - Open both manifold valves and start the vacuum pump.
- 5 - Evacuate the line set and indoor unit to an **absolute pressure** of 23,000 microns (29.01 inches of mercury). During the early stages of evacuation, it is desirable to close the manifold gauge valve at least once to determine if there is a rapid rise in **absolute pressure**. A rapid rise in pressure indicates a relatively large leak. If this occurs, repeat the leak testing procedure.
*NOTE - The term **absolute pressure** means the total actual pressure within a given volume or system, above the absolute zero of pressure. Absolute pressure in a vacuum is equal to atmospheric pressure minus vacuum pressure.*
- 6 - When the absolute pressure reaches 23,000 microns (29.01 inches of mercury), close the manifold gauge valves, turn off the vacuum pump and disconnect the manifold gauge center port hose from vacuum pump. Attach the manifold center port hose to a nitrogen cylinder with pressure regulator set to 150 psig (1034 kPa) and purge the hose. Open the manifold gauge valves to break the vacuum in the line set and indoor unit. Close the manifold gauge valves.

⚠ CAUTION

Danger of Equipment Damage.
Avoid deep vacuum operation. Do not use compressors to evacuate a system.
Extremely low vacuums can cause internal arcing and compressor failure.
Damage caused by deep vacuum operation will void warranty.

- 7 - Shut off the nitrogen cylinder and remove the manifold gauge hose from the cylinder. Open the manifold gauge valves to release the nitrogen from the line set and indoor unit.
- 8 - Reconnect the manifold gauge to the vacuum pump, turn the pump on, and continue to evacuate the line set and indoor unit until the absolute pressure does not rise above 500 microns (29.9 inches of mercury) within a 20-minute period after shutting off the vacuum pump and closing the manifold gauge valves.
- 9 - When the absolute pressure requirement above has been met, disconnect the manifold hose from the vacuum pump and connect it to an upright cylinder of R-410A refrigerant. Open the manifold gauge valves to break the vacuum from 1 to 2 psig positive pressure in the line set and indoor unit. Close manifold gauge valves and shut off the R-410A cylinder and remove the manifold gauge set.

C-Charging

⚠ IMPORTANT

Mineral oils are not compatible with R-410A. If oil must be added, it must be a polyol ester oil.

Weighing in the Charge TXV Systems – Outdoor Temp < 65°F (18°C)

If the system is void of refrigerant, or if the outdoor ambient temperature is cool, the refrigerant charge should be weighed into the unit. Do this after any leaks have been repaired.

- 1 - Recover the refrigerant from the unit.
- 2 - Conduct a leak check, then evacuate as previously outlined.
- 3 - Weigh in the unit nameplate charge.

If weighing facilities are not available or if you are charging the unit during warm weather, follow one of the other procedures outlined below.

Subcooling Method Outdoor Temp. < 65°F (18°C)

When the outdoor ambient temperature is below 65°F (18°C), use the subcooling method to charge the unit. It may be necessary to restrict the air flow through the outdoor coil to achieve pressures in the 325-375 psig (2240-2585 kPa) range. These higher pressures are necessary for checking the charge. Block equal sections of air intake panels and move obstructions sideways until the liquid pressure is in the 325-375 psig (2240-2585 kPa) range. See figure 19.

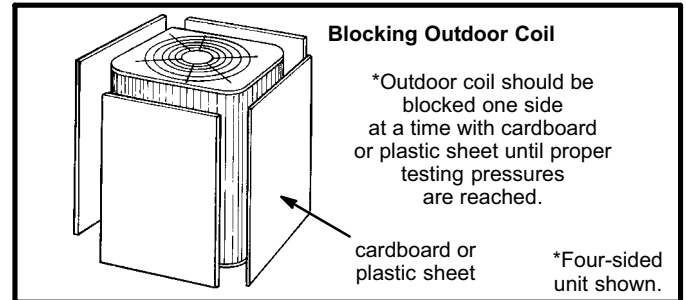

FIGURE 19

- 1 - With the manifold gauge hose still on the liquid service port and the unit operating stably, use a digital thermometer to record the liquid line temperature.
- 2 - At the same time, record the liquid line pressure reading.
- 3 - Use a temperature/pressure chart for R-410A to determine the saturation temperature for the liquid line pressure reading. See table 11.
- 4 - Subtract the liquid line temperature from the saturation temperature (according to the chart) to determine subcooling. **(Saturation temperature - Liquid line temperature = Subcooling)**
- 5 - Compare the subcooling value with those in table 8. If subcooling is greater than shown, recover some refrigerant. If subcooling is less than shown, add some refrigerant. Be aware of the R-410A refrigerant cylinder. It will be light maroon-colored. Refrigerant should be added through the vapor line valve in the liquid state. **Some R-410A cylinders are equipped with a dip tube that allows you to draw liquid refrigerant from the bottom of the cylinder without turning the cylinder upside-down. The cylinder will be marked if it is equipped with a dip tube.**

TABLE 8
Subcooling Values for Charging

Model Number	Second Stage (High Capacity) Saturation Temp. - Liquid Line Temp. °F (°C)
XC21-024	7.0 ± 1 (3.9 ± .5)
XC21-036	8.2 ± 1 (4.56 ± .5)
XC21-048	6.0 ± 1 (3.33 ± .5)
XC21-060	6.0 ± 1 (3.33 ± .5)

The following procedure is intended as a general guide and is for use on expansion valve systems only. For best results, indoor temperature should be 70°F (21°C) to 80°F (26°C). Monitor system pressures while charging.

- 1 - Record outdoor ambient temperature using a digital thermometer.
- 2 - Attach high pressure gauge set and operate unit for several minutes to allow system pressures to stabilize.
- 3 - Compare stabilized pressures with those provided in table 10, "Normal Operating Pressures." Minor variations in these pressures may be expected due to differences in installations. Significant differences could mean that the system is not properly charged or that a problem exists with some component in the system. Pressures higher than those listed indicate that the system is overcharged. Pressures lower than those listed indicate that the system is undercharged. A temperature/pressure chart for R-410A refrigerant is provided in table 5 for your convenience. Verify adjusted charge using the approach method.

Approach Method

- 4 - Use the same digital thermometer you used to check the outdoor ambient temperature to check the liquid line temperature.
- 5 - The difference between the ambient and liquid temperatures should match values given in table 9. If the values don't agree with those in table 9, add refrigerant to lower the approach temperature, or recover refrigerant from the system to increase the approach temperature. Be aware of the R-410A refrigerant cylinder. It will be light maroon-colored. Refrigerant should be added through the vapor valve in the liquid state. **Some R-410A cylinders are equipped with a dip tube which allows you to draw liquid refrigerant from the bottom of the cylinder without turning the cylinder upside-down. The cylinder will be marked if it is equipped with a dip tube.**

TABLE 9
APPROACH TEMPERATURES

Model No.	Second Stage (High Capacity) Liquid Line - Outdoor Ambient °F (°C)
XC21-024	2.5 ± 1 (1.48 ± .5)
XC21-036	4.5 ± 1 (2.50 ± .5)
XC21-048	4.5 ± 1 (2.50 ± .5)
XC21-060	10.0 ± 1 (5.56 ± .5)

NOTE - For best results, the same electronic thermometer should be used to check both outdoor ambient and liquid line temperatures.

⚠ IMPORTANT

Use table 10 to perform maintenance checks. Table 10 is not a procedure for charging the system. Minor variations in these pressures may be due to differences in installations. Significant deviations could mean that the system is not properly charged or that a problem exists with some component in the system.

⚠ IMPORTANT

REFRIGERANT SHOULD BE ADDED THROUGH THE VAPOR VALVE IN THE LIQUID STATE.

D-Oil Charge

Refer to compressor nameplate.

TABLE 10
NORMAL OPERATING PRESSURES
(Liquid ±10 and Suction ±5 psig)

Temp. of air entering outdoor coil °F (°C)	-024		-036		-048		-060	
	Liq-uid	Suc-tion	Liq-uid	Suc-tion	Liq-uid	Suc-tion	Liq-uid	Suc-tion
First Stage (Low Capacity)								
65 (18.3)	205	148	214	148	215	140	228	137
75 (23.9)	242	150	247	151	250	142	265	139
85 (29.4)	281	152	286	152	288	144	296	142
95 (35.0)	323	154	341	154	338	146	353	146
105 (40.6)	372	156	381	156	387	149	400	149
115 (46.1)	428	159	441	158	459	152	472	151
Second Stage (High Capacity)								
65 (18.3)	217	145	218	131	217	124	234	116
75 (23.9)	250	147	253	141	251	133	273	125
85 (29.4)	289	149	290	146	289	138	314	132
95 (35.0)	336	151	339	149	336	141	360	139
105 (40.6)	383	153	387	152	385	144	405	143
115 (46.1)	438	155	443	154	437	146	461	147

**These are typical pressures only. Indoor match up, indoor air, and indoor load will cause the pressures to vary.*

TABLE 11
R-410A Temperature/Pressure Chart

Temperature °F	Pressure Psig	Temperature °F	Pressure Psig	Temperature °F	Pressure Psig	Temperature °F	Pressure Psig
32	100.8	63	178.5	94	290.8	125	445.9
33	102.9	64	181.6	95	295.1	126	451.8
34	105.0	65	184.3	96	299.4	127	457.6
35	107.1	66	187.7	97	303.8	128	463.5
36	109.2	67	190.9	98	308.2	129	469.5
37	111.4	68	194.1	99	312.7	130	475.6
38	113.6	69	197.3	100	317.2	131	481.6
39	115.8	70	200.6	101	321.8	132	487.8
40	118.0	71	203.9	102	326.4	133	494.0
41	120.3	72	207.2	103	331.0	134	500.2
42	122.6	73	210.6	104	335.7	135	506.5
43	125.0	74	214.0	105	340.5	136	512.9
44	127.3	75	217.4	106	345.3	137	519.3
45	129.7	76	220.9	107	350.1	138	525.8
46	132.2	77	224.4	108	355.0	139	532.4
47	134.6	78	228.0	109	360.0	140	539.0
48	137.1	79	231.6	110	365.0	141	545.6
49	139.6	80	235.3	111	370.0	142	552.3
50	142.2	81	239.0	112	375.1	143	559.1
51	144.8	82	242.7	113	380.2	144	565.9
52	147.4	83	246.5	114	385.4	145	572.8
53	150.1	84	250.3	115	390.7	146	579.8
54	152.8	85	254.1	116	396.0	147	586.8
55	155.5	86	258.0	117	401.3	148	593.8
56	158.2	87	262.0	118	406.7	149	601.0
57	161.0	88	266.0	119	412.2	150	608.1
58	163.9	89	270.0	120	417.7	151	615.4
59	166.7	90	274.1	121	423.2	152	622.7
60	169.6	91	278.2	122	428.8	153	630.1
61	172.6	92	282.3	123	434.5	154	637.5
62	195.5	93	286.5	124	440.2	155	645.0

V-SERVICE AND RECOVERY

⚠ WARNING

Polyol ester (POE) oils used with R-410A refrigerant absorb moisture very quickly. It is very important that the refrigerant system be kept closed as much as possible. **DO NOT** remove line set caps or service valve stub caps until you are ready to make connections.

⚠ IMPORTANT

USE RECOVERY MACHINE RATED FOR R-410A REFRIGERANT.

If the XC21 system must be opened for any kind of service, such as compressor or filter drier replacement, you must take extra precautions to prevent moisture from entering the system. The following steps will help to minimize the amount of moisture that enters the system during recovery of R-410A.

- 1 - Use a regulator-equipped nitrogen cylinder to break the system vacuum. Do not exceed 5 psi. The dry nitrogen will fill the system, purging any moisture.
- 2 - Remove the faulty component and quickly seal the system (using tape or some other means) to prevent additional moisture from entering the system.
- 3 - Do not remove the tape until you are ready to install new component. Quickly install the replacement component.
- 4 - Evacuate the system to remove any moisture and other non-condensables.

The XC21 system MUST be checked for moisture anytime the system is opened.

Any moisture not absorbed by the polyol ester oil can be removed by triple evacuation. Moisture that has been absorbed by the compressor oil can be removed by replacing the filter drier.

⚠ IMPORTANT

Evacuation of system only will not remove moisture from oil. Filter drier must be replaced to eliminate moisture from POE oil.

VI-MAINTENANCE

⚠ WARNING



Electric shock hazard. Can cause injury or death. Before attempting to perform any service or maintenance, turn the electrical power to unit OFF at disconnect switch(es). Unit may have multiple power supplies.

See section II- for removing access panels. Maintenance and service must be performed by a qualified installer or service agency. At the beginning of each cooling season, the system should be checked as follows:

- 1 - Clean and inspect the outdoor coil. The coil may be flushed with a water hose. Ensure the power is turned off before you clean the coil.
- 2 - Condenser fan motor is prelubricated and sealed. No further lubrication is needed.
- 3 - Visually inspect connecting lines and coils for evidence of oil leaks.
- 4 - Check wiring for loose connections.
- 5 - Check for correct voltage at unit (unit operating).
- 6 - Check amp-draw on condenser fan motor.

NOTE - If owner complains of insufficient cooling, the unit should be gauged and refrigerant charge checked. Refer to section on refrigerant charging in this instruction.

VII-DIAGRAMS / OPERATING SEQUENCE

A- Unit Diagram XC21-024/060-1P

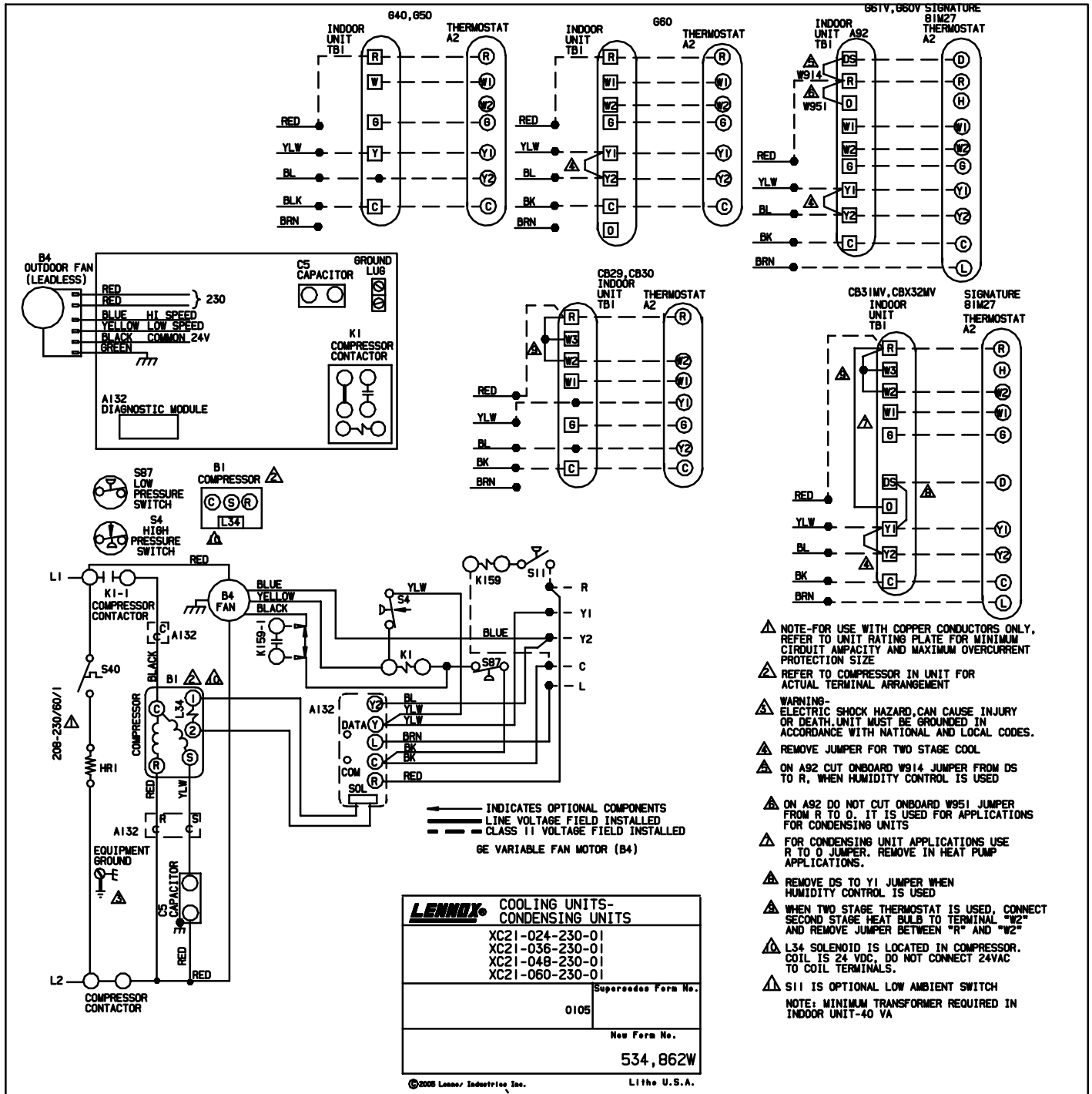

Sequence of Operation

NOTE - First and second stage cool operate independent of each other and can modulate back and forth according to thermostat demand.

First Stage Cool (low capacity)

- Cooling demand initiates at Y1 in the thermostat.
- Voltage from terminal Y passes through S4 high pressure switch, energizes K1 compressor contactor, passes through S87 low pressure switch and returns to common side of the 24VAC power.

- K1 closes energizing compressor B1 and outdoor fan B4. Outdoor fan motor energizes on low speed (yellow tap).
- Solenoid L34 is NOT energized so the slider ring remains open, limiting compressor to low capacity.

Second Stage (high capacity)

NOTE - Compressor is operating in first stage cool

- Second stage cool thermostat demand sends voltage to the LSOM. After 5 second delay the LSOM converts the AC voltage to DC voltage and energizes solenoid L34. L34 then closes slider ring allowing the compressor to operate on high capacity. Variable speed condenser operates on high speed (blue tap).