

TSA*S4 COMMERCIAL SERIES UNITS

The TSA*S4 is a commercial split-system condensing unit with SEER ratings up to 14.80. The series is designed for use with expansion valves (TXV) and R-410A refrigerant. All TSA*S4 units utilize scroll compressors.

TSA*S4 condensing units are available in 3, 3-1/2, 4 and 5 ton capacities. All major components (indoor blower and coil) must be matched according to Lennox recommendations for the compressor to be covered under warranty. Refer to the Engineering Handbook for approved system matchups.

Information contained in this manual is intended for use by qualified service technicians only. All specifications are subject to change.

This manual is divided into sections which discuss the major components, refrigerant system, charging procedure, maintenance and operation sequence.

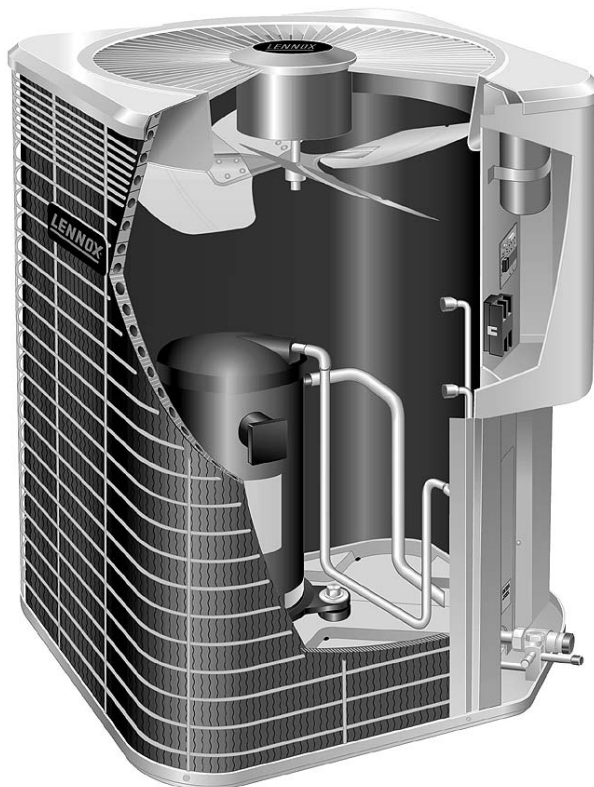

ELECTROSTATIC DISCHARGE (ESD)
Precautions and Procedures

⚠ WARNING

Improper installation, adjustment, alteration, service or maintenance can cause property damage, personal injury or loss of life. Installation and service must be performed by a qualified installer or service agency.

⚠ WARNING

Refrigerant can be harmful if it is inhaled. Refrigerant must be used and recovered responsibly.

Failure to follow this warning may result in personal injury or death.

⚠ CAUTION

Electrostatic discharge can affect electronic components. Take precautions during unit installation and service to protect the unit's electronic controls. Precautions will help to avoid control exposure to electrostatic discharge by putting the unit, the control and the technician at the same electrostatic potential. Neutralize electrostatic charge by touching hand and all tools on an unpainted unit surface before performing any service procedure.

⚠ IMPORTANT

The Clean Air Act of 1990 bans the intentional venting of (CFC's and HFC's) as of July 1, 1992. Approved methods of recovery, recycling or reclaiming must be followed. Fines and/or incarceration may be levied for noncompliance.

TABLE OF CONTENTS

General Page 1
 Specifications / Electrical Data Page 2
 Optional Accessories Page 3
 I Unit Components Page 4
 II Refrigerant System Page 6
 III Charging Page 7
 IV Maintenance Page 12
 V Wiring and Operating Sequence Page 13

SPECIFICATIONS

General Data		Model No.	TSA036S4	TSA042S4	TSA048S4	TSA060S4-2
		Nominal Tonnage	3	3.5	4	5
Connections (sweat)	Liquid line o.d. - in.		3/8	3/8	3/8	3/8
	Suction line o.d. - in.		7/8	7/8	7/8	1-1/8
¹ Refrigerant (R-410A) furnished			6 lbs. 7 oz.	8 lbs. 3 oz.	8 lbs. 4 oz.	10 lbs. 0 oz. -1 units 11 lbs. 2 oz.
Outdoor Coil	Net face area - sq. ft.	Outer coil	13.22	15.11	16.32	21.0
		Inner coil	12.60	14.40	15.71	20.25
	Tube diameter - in.		5/16	5/16	5/16	5/16
	Fins per inch - No. of rows		22 - 2	22 - 2	22 - 2	22 - 2
Outdoor Fan	Diam. - in. - No. of blades		18 - 4	18 - 4	22 - 4	22 - 4
	Motor hp		208/230V - 1/5 460V - 1/6	1/3	1/4	1/4
	Cfm		2450	2930	3500	3830
	Rpm		1100	1100	825	825
	Watts		200	310	320	330
Shipping Data - lbs. 1 package			150	177	200	222

ELECTRICAL DATA

Line voltage data - 60 hz - 3ph		208/230V	460V	208/230V	460V	208/230V	460V	575V	208/230V	460V	575V
² Maximum overcurrent protection (amps)		20	15	30	15	30	15	15	35	15	15
³ Minimum circuit ampacity		14.2	7.8	18.6	8.3	18.8	8.8	7.0	21.3	10.7	8.3
Compressor	Rated load amps	10.4	5.8	13.5	6.0	13.7	6.2	4.8	15.6	7.8	5.8
	Power factor	.85	.84	.83	.81	.90	.92	.88	.90	.91	.90
	Locked rotor amps	88	38	88	44	83.1	41	30.4	110	52	35.5
Outdoor Fan Motor	Full load amps	1.1	.55	1.7	1.0	1.7	1.0	1.0	1.7	1.0	1.0
	Locked rotor amps	1.9	1.1	4.1	2.2	3.1	2.3	2.3	3.1	2.3	2.3

OPTIONAL ACCESSORIES - must be ordered extra

Model No.		TSA036S4	TSA042S4	TSA048S4	TSA060S4
Compressor Low Ambient Cut-Off	45F08	•	•	•	•
Compressor Sound Cover	69J03	•	•	•	•
Compressor Time-Off Control	47J27	•	•	•	•
Freezestat	3/8 in. tubing	93G35	•	•	•
	5/8 in. tubing	50A93	•	•	•
Hail Guards	92M88	•			
	92M89		•		
	45M56			•	
	92M90				•
Loss of Charge Kit	84M23	•	•	•	•
⁴ Low Ambient Kit (down to 30°F)	34M72	•	•	•	•
Low Ambient Control Option (down to 30°F)		See table below	See table below	See table below	See table below
Mounting Base	69J06	•	•		
	69J07			•	•
Refrigerant Line Sets	L15-65-30, L15-65-40, L15-65-50	•	•	•	
	Field Fabricate				•
Time Delay Relay Kit	58M81	•	•	•	•
Unit Stand-Off Kit	94J45	•	•	•	•

NOTE — Extremes of operating range are plus 10% and minus 5% of line voltage.

¹ Refrigerant charge sufficient for 15 ft. (4.6 m) length of refrigerant lines.

² HACR type circuit breaker or fuse.

³ Refer to National or Canadian Electrical Code manual to determine wire, fuse and disconnect size requirements.

⁴ Freezestat is recommended with Low Ambient Kit.

LOW AMBIENT CONTROL Option (Down to 0°F)

Order one each: Speed Control Kit, Weatherproof Kit, Outdoor Fan Motor and Capacitor

Model No.		TSA036S2	TSA042S2	TSA048S2	TSA060S2
Speed Control Kit	X5867	•	•	•	•
Weatherproof Kit	56N41	•	•	•	•
Outdoor Fan Motor	1/2 HP - 230V	69H75	•	•	•
	460V	69H76	•	•	•
Capacitor	with mounting bracket	53H06	•	•	•

I - UNIT COMPONENTS

⚠ DANGER

Electric Shock Hazard.
May cause injury or death.

Disconnect all remote electrical power supplies before opening unit panel.
Unit may have multiple power supplies.

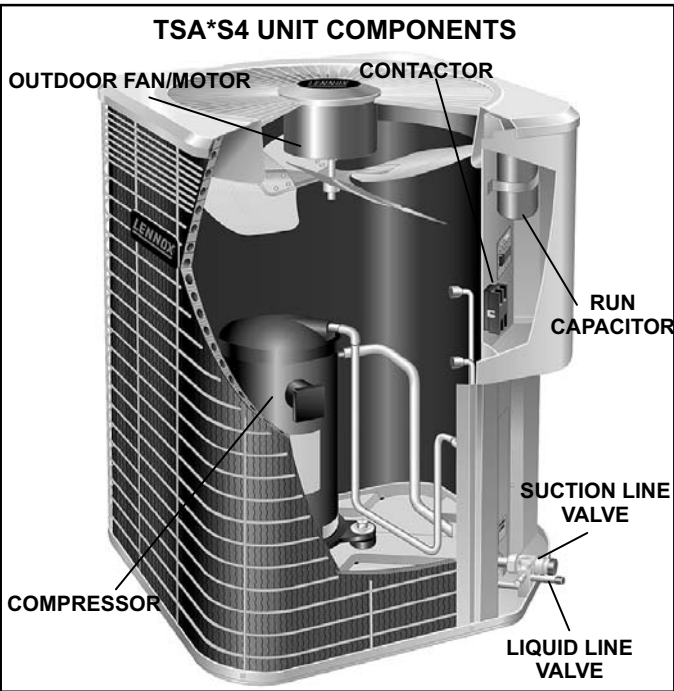

FIGURE 1

Control Box

TSA*S4 units are not equipped with a 24V transformer. All 24 VAC controls are powered by the indoor unit. Refer to wiring diagram.

Electrical openings are provided under the control box cover. Field thermostat wiring is made to color-coded pigtail connections.

1-Compressor Contactor K1

The compressor is energized by a contactor located in the control box. See figure 1. Three-pole contactors are used in TSA*S4 series units. K1 is energized by the indoor thermostat terminal Y1 (24V) when thermostat demand is present.

2-Condenser Fan Motor B4 & Capacitor C1

All units use single-phase PSC fan motors which require a run capacitor C1 located in the control box. Ratings for C1 will be on fan motor nameplate. In all units, the condenser fan is controlled by the compressor contactor.

ELECTRICAL DATA tables in this manual show specifications for condenser fans used in TSA*S4s.

Access to the condenser fan motor on all units is gained by removing the seven screws securing the fan assembly. See figure 2. The condenser fan motor is removed from the fan guard by removing the four nuts found on the top panel. Drip loops should be used in wiring when servicing motor. See figure 3 if condenser fan motor replacement is necessary.

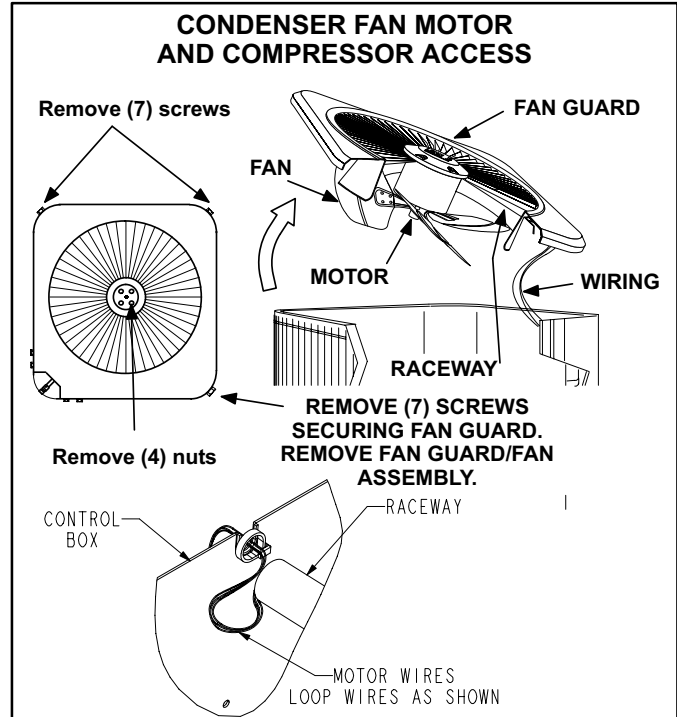

FIGURE 2

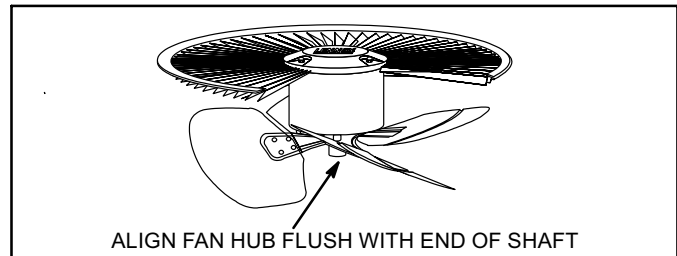

FIGURE 3

3-High Pressure Switch S4

The manual-reset high pressure switch is located in the liquid line. When liquid line pressure exceeds the factory setting of 590 ± 10 psi, the switch opens and shuts off the compressor.

4-Loss of Charge Switch S24 (Field Installed Option)

The loss of charge switch is N.C. auto re-set and located on the liquid line of the compressor. The switch opens when liquid line pressure drops to 25 ± 5 psig and shuts off the compressor. The switch closes on a pressure rise at 55 ± 5 psig. The settings are factory set and cannot be adjusted.

5-Transformer T4 J voltage only

Transformer T4 is located in the control box and is energized anytime the condenser fan motor is operational.

6-Crankcase Heater HR1 & Optional Thermostat S40

Crankcase heater HR1 prevents liquid from accumulating in the compressor. HR1 is controlled by optional crankcase heater thermostat S40, located on the liquid line. When liquid line temperature drops below 50° F, S40 closes energizing HR1. S40 opens when liquid line temperature reaches 70°.

7-Drier

A filter drier designed for all TSA4*S4 model units is located in the liquid line. The field installed drier is designed to remove moisture, which can lead to compressor failure. **Any time unit is exposed to open air due to service, drier must be replaced. All replacement driers must be approved for R410A refrigerant.**

8-Compressor

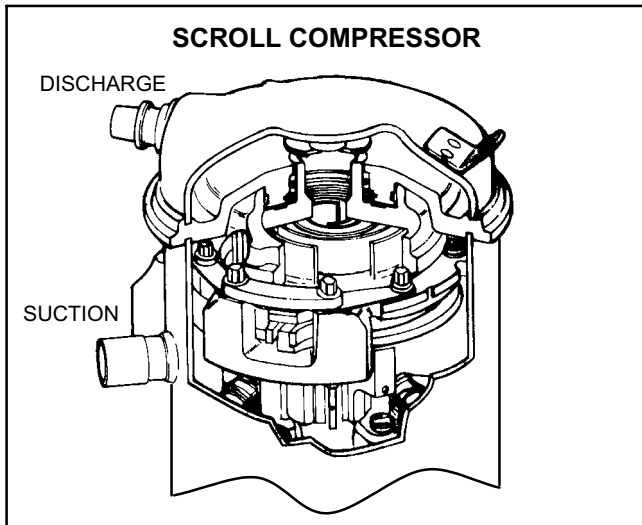

FIGURE 4

All TSA*S4 units utilize a scroll compressor. The scroll compressor design is simple, efficient and requires few moving parts. A cutaway diagram of the scroll compressor is shown in figure 4. The scrolls are located in the top of the compressor can and the motor is located just below. The oil level is immediately below the motor.

The scroll is a simple compression concept centered around the unique spiral shape of the scroll and its inherent properties. Two identical scrolls are mated together forming concentric spiral shapes (figure 5). One scroll remains stationary, while the other is allowed to "orbit" (figure 6). Note that the orbiting scroll does not rotate or turn but merely orbits the stationary scroll.

NOTE - During operation, the head of a scroll compressor may be hot since it is in constant contact with discharge gas.

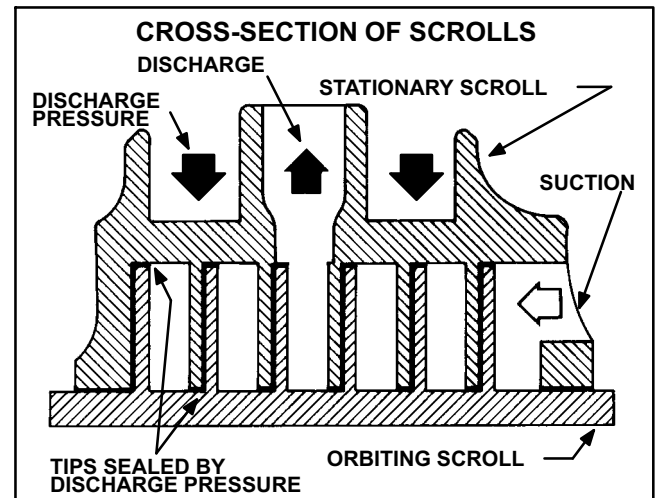

FIGURE 5

The counterclockwise orbiting scroll draws gas into the outer crescent shaped gas pocket created by the two scrolls (figure 6 - 1). The centrifugal action of the orbiting scroll seals off the flanks of the scrolls (figure 6 - 2). As the orbiting motion continues, the gas is forced toward the center of the scroll and the gas pocket becomes compressed (figure 6 - 3). When the compressed gas reaches the center, it is discharged vertically into a chamber and discharge port in the top of the compressor (figure 5). The discharge pressure forcing down on the top scroll helps seal off the upper and lower edges (tips) of the scrolls (figure 5). During a single orbit, several pockets of gas are compressed simultaneously providing smooth continuous compression.

The scroll compressor is tolerant to the effects of liquid return. If liquid enters the scrolls, the orbiting scroll is allowed to separate from the stationary scroll. The liquid is worked toward the center of the scroll and is discharged. If the compressor is replaced, conventional Lennox cleanup practices must be used. Due to its efficiency, the scroll compressor is capable of drawing a much deeper vacuum than reciprocating compressors. Deep vacuum operation can cause internal fusite arcing resulting in damaged internal parts and will result in compressor failure. Never use a scroll compressor for evacuating or to pump system into a vacuum. This type of damage can be detected and will result in denial of warranty claims.

The scroll compressor is quieter than a reciprocating compressor, however, the two compressors have much different sound characteristics. The sounds made by a scroll compressor do not affect system reliability, performance, or indicate damage.

See compressor nameplate or ELECTRICAL DATA for compressor specifications.

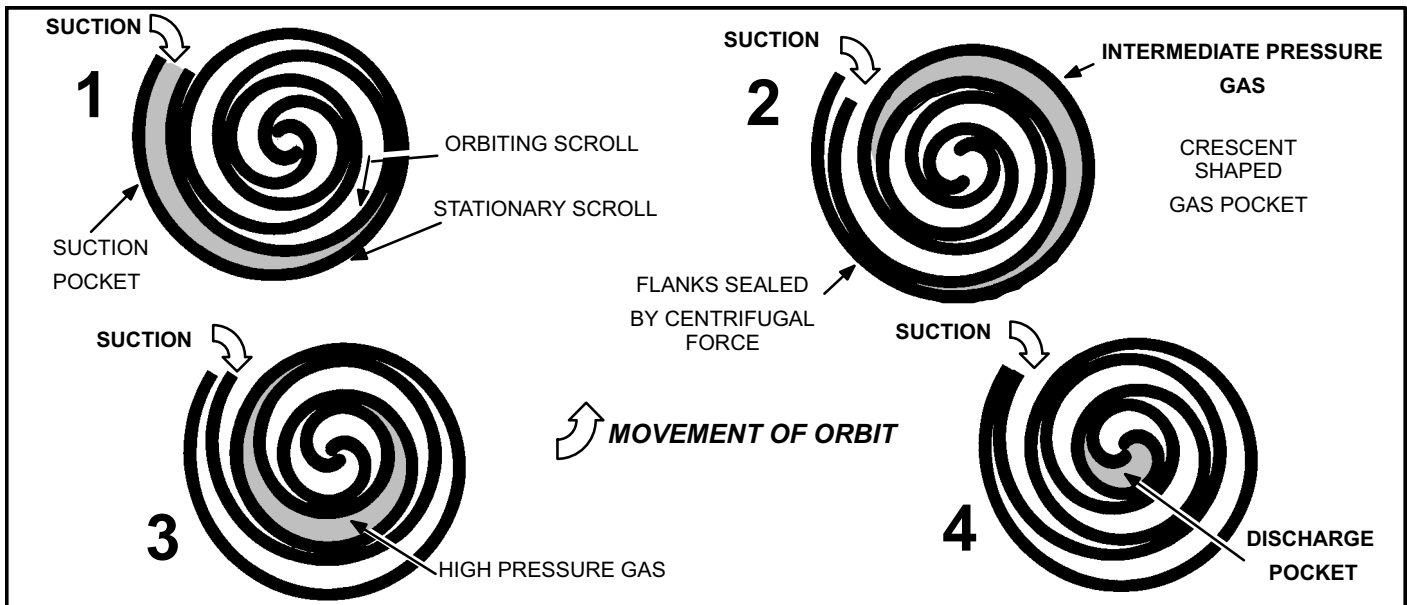

FIGURE 6

II - REFRIGERANT SYSTEM

A - Plumbing

Field refrigerant piping consists of liquid and suction lines from the condensing unit (sweat connections) to the indoor evaporator coil (flare or sweat connections). Use Lennox L15 (sweat) series line sets as shown in table 1.

TABLE 1

Refrigerant Line Sets					
Model	Valve Field Size Connections		Recommended Line Set		
	Liquid Line	Suction Line	Liquid Line	Suction Line	L15 Line Sets
-036 -042 -048	3/8 in. (10 mm)	7/8 in. (22 mm)	3/8 in. (10 mm)	7/8 in. (22 mm)	L15-65 15 ft. - 50 ft. (4.6 m - 15 m)
-060	3/8 in. (10 mm)	1-1/8 in. (29 mm)	3/8 in. (10 mm)	1-1/8 in. (29 mm)	Field Fabricated

B - Service Valves

The liquid line and suction line service valves (figures 7 and 8) and gauge ports are used for leak testing, evacuating, charging and checking charge. Valves cannot be serviced. If a valve has failed, you must replace it.

Each valve is equipped with a service port which has a factory-installed Schrader valve. A service port cap protects the Schrader valve from contamination and serves as the primary leak seal.

To Access Schrader Port:

- 1 - Remove service port cap with an adjustable wrench.
- 2 - Connect gauge to the service port.
- 3 - When testing is complete, replace service port cap. Tighten finger tight, then an additional 1/6 turn.

To Open Service Valve:

- 1 - Remove the stem cap with an adjustable wrench.
- 2 - Use a service wrench with a hex-head extension to back the stem out counterclockwise as far as it will go.
NOTE - Use a 3/16" hex head extension for liquid line sizes or a 5/16" extension for vapor line sizes.
- 3 - Replace the stem cap. Tighten finger tight, then tighten an additional 1/6 turn.

To Close Service Valve:

- 1 - Remove the stem cap with an adjustable wrench.
- 2 - Use a service wrench with a hex-head extension to turn the stem clockwise to seat the valve. Tighten the stem firmly.
NOTE - Use a 3/16" hex head extension for liquid line sizes or a 5/16" extension for vapor line sizes.
- 3 - Replace the stem cap. Tighten finger tight, then tighten an additional 1/6 turn.

Ball Valve (5 ton only)

Ball valves function the same way as the other valves, the difference is in the construction. A ball valve is illustrated in figure 8.

The ball valve is equipped with a service port with a factory-installed Schrader valve. A service port cap protects the Schrader valve from contamination and assures a leak-free seal.

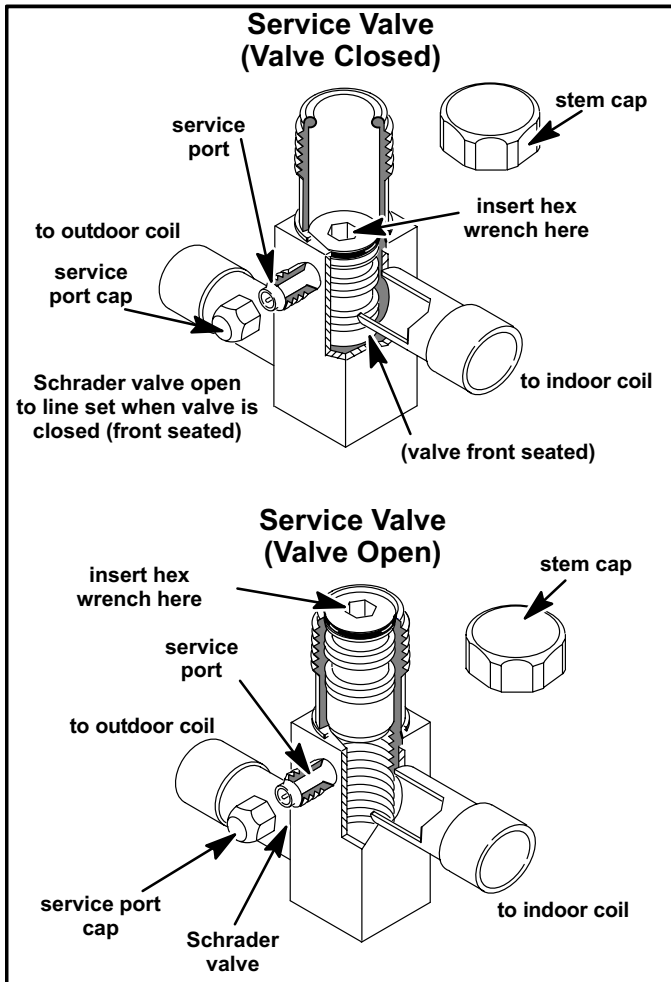

FIGURE 7

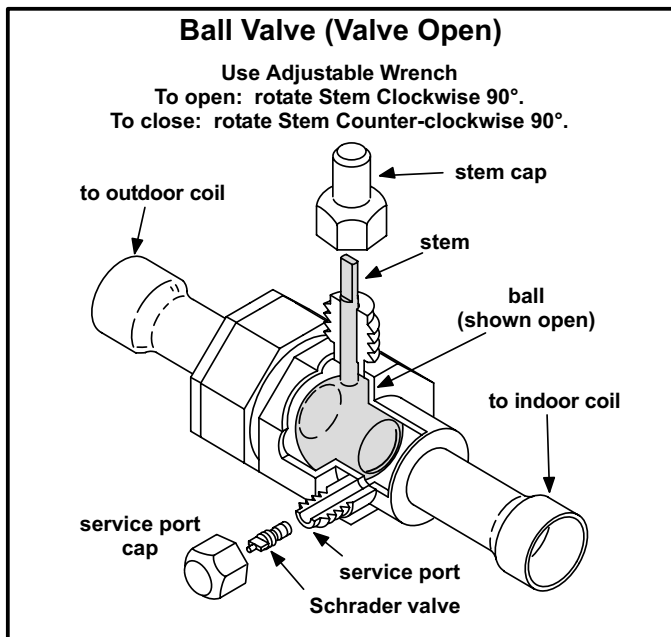

FIGURE 8

III - CHARGING

A - Pumping Down System

⚠ CAUTION

Deep vacuum operation (operating compressor below 0 psig) can cause internal fuse arcing resulting in a damaged or failed compressor. This type of damage will result in denial of warranty claim.

The system may be pumped down when leak checking the line set and indoor coil or making repairs to the line set or indoor coil. Attach gauge manifold then follow below:

- 1- Close liquid line valve.
- 2- Start outdoor unit.
- 3- Monitor suction gauge. Stop unit when 0 psig is reached.
- 4- Close vapor line valve.

B - Leak Testing

After the line set has been connected to the indoor and outdoor units, check the line set connections and indoor unit for leaks.

⚠ WARNING

Refrigerant can be harmful if it is inhaled. Refrigerant must be used and recovered responsibly.

Failure to follow this warning may result in personal injury or death.

⚠ WARNING



Fire, Explosion and Personal Safety Hazard.

Failure to follow this warning could result in damage, personal injury or death.

Never use oxygen to pressurize or purge refrigeration lines. Oxygen, when exposed to a spark or open flame, can cause damage by fire and / or an explosion, that can result in personal injury or death.

WARNING



Danger of explosion!

When using a high pressure gas such as dry nitrogen to pressurize a refrigerant or air conditioning system, use a regulator that can control the pressure down to 1 or 2 psig (6.9 to 13.8 kPa).

Using an Electronic Leak Detector or Halide

- 1 - Connect a cylinder of R-410A to the center port of the manifold gauge set.
- 2 - With both manifold valves closed, open the valve on the R-410A cylinder (vapor only).
- 3 - Open the high pressure side of the manifold to allow the R-410A into the line set and indoor unit. Weigh in a trace amount of R-410A. [A trace amount is a maximum of 2 ounces (57 g) or 3 pounds (31 kPa) pressure.] Close the valve on the R-410A cylinder and the valve on the high pressure side of the manifold gauge set. Disconnect the R-410A cylinder.
- 4 - Connect a cylinder of nitrogen with a pressure regulating valve to the center port of the manifold gauge set.
- 5 - Connect the manifold gauge set high pressure hose to the vapor valve service port. (*Normally, the high pressure hose is connected to the liquid line port; however, connecting it to the vapor port better protects the manifold gauge set from high pressure damage.*)
- 6 - Adjust the nitrogen pressure to 150 psig (1034 kPa). Open the valve on the high side of the manifold gauge set which will pressurize line set and indoor unit.
- 7 - After a few minutes, open a refrigerant port to ensure the refrigerant you added is adequate to be detected. (Amounts of refrigerant will vary with line lengths.) Check all joints for leaks. Purge nitrogen and R-410A mixture. Correct any leaks and recheck.

C - Evacuating the System

Evacuating the system of noncondensables is critical for proper operation of the unit. Noncondensables are defined as any gas that will not condense under temperatures and pressures present during operation of an air conditioning system. Noncondensables and water vapor combine with refrigerant to produce substances that corrode copper piping and compressor parts.

NOTE - This evacuation process is adequate for a new installation with clean and dry lines. If excessive moisture is present, the evacuation process may be required more than once.

IMPORTANT

Use a thermocouple or thermistor electronic vacuum gauge that is calibrated in microns. Use an instrument that reads from 50 microns to at least 10,000 microns.

- 1 - Connect manifold gauge set to the service valve ports :
 - low pressure gauge to *vapor* line service valve
 - high pressure gauge to *liquid* line service valve
- 2 - Connect micron gauge.
- 3 - Connect the vacuum pump (with vacuum gauge) to the center port of the manifold gauge set.
- 4 - Open both manifold valves and start the vacuum pump.
- 5 - Evacuate the line set and indoor unit to an **absolute pressure** of 23,000 microns (29.01 inches of mercury). During the early stages of evacuation, it is desirable to close the manifold gauge valve at least once to determine if there is a rapid rise in **absolute pressure**. A rapid rise in pressure indicates a relatively large leak. If this occurs, repeat the leak testing procedure.

*NOTE - The term **absolute pressure** means the total actual pressure within a given volume or system, above the absolute zero of pressure. Absolute pressure in a vacuum is equal to atmospheric pressure minus vacuum pressure.*
- 6 - When the absolute pressure reaches 23,000 microns (29.01 inches of mercury), close the manifold gauge valves, turn off the vacuum pump and disconnect the manifold gauge center port hose from vacuum pump. Attach the manifold center port hose to a nitrogen cylinder with pressure regulator set to 150 psig (1034 kPa) and purge the hose. Open the manifold gauge valves to break the vacuum in the line set and indoor unit. Close the manifold gauge valves.

CAUTION

Danger of Equipment Damage.
Avoid deep vacuum operation. Do not use compressors to evacuate a system.
Extremely low vacuums can cause internal arcing and compressor failure.
Damage caused by deep vacuum operation will void warranty.

- 7 - Shut off the nitrogen cylinder and remove the manifold gauge hose from the cylinder. Open the manifold gauge valves to release the nitrogen from the line set and indoor unit.
- 8 - Reconnect the manifold gauge to the vacuum pump, turn the pump on, and continue to evacuate the line set and indoor unit until the absolute pressure does not rise above 500 microns (29.9 inches of mercury) within a 20-minute period after shutting off the vacuum pump and closing the manifold gauge valves.
- 9 - When the absolute pressure requirement above has been met, disconnect the manifold hose from the vacuum pump and connect it to an upright cylinder of R-410A refrigerant. Open the manifold gauge valves to break the vacuum from 1 to 2 psig positive pressure in the line set and indoor unit. Close manifold gauge valves and shut off the R-410A cylinder and remove the manifold gauge set.

D - Charging

This system is charged with R-410A refrigerant which operates at much higher pressures than HCFC-22. The recommended check expansion valve is approved for use with R-410A. Do not replace it with a valve that is designed to be used with HCFC-22. This unit is NOT approved for use with coils that include metering orifices or capillary tubes.

Check Indoor Airflow before Charging

NOTE - Be sure that filters and indoor and outdoor coils are clean before testing.

Check indoor airflow using the step procedures as illustrated in figure 9.

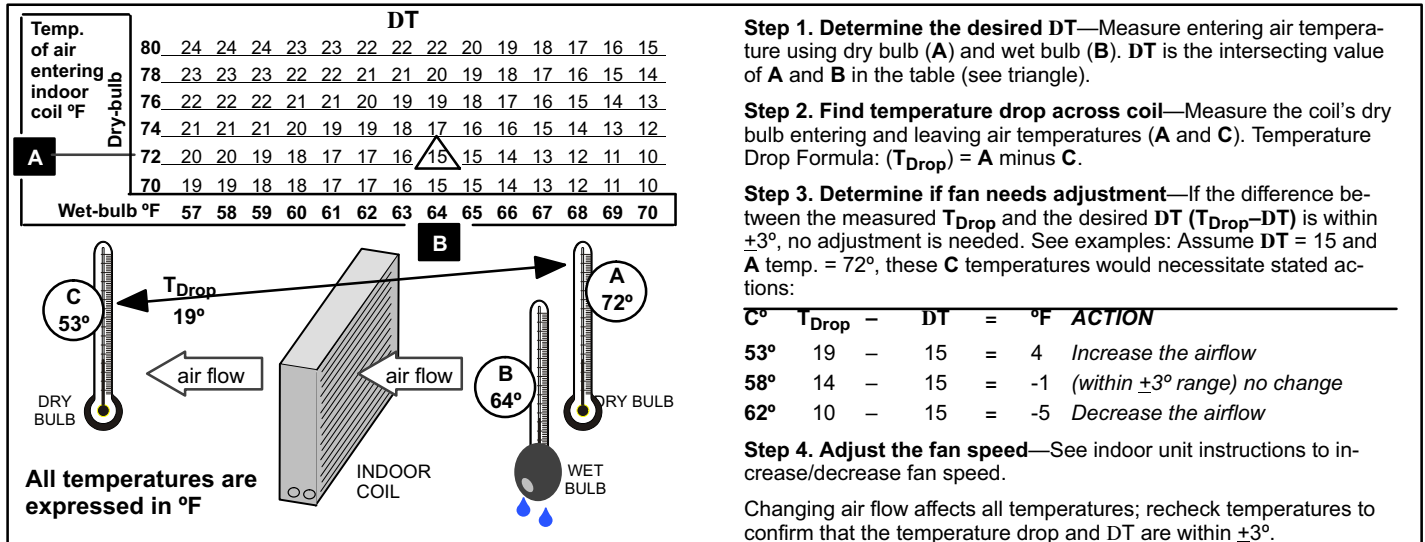

FIGURE 9

Pre-Charge Maintenance Checks

! IMPORTANT

Use this table to perform maintenance checks; it is not a procedure for charging the system. Minor variations in these pressures may be due to differences in installations. Significant deviations could mean that the system is not properly charged or that a problem exists with some component in the system.

Table 2
Normal Operating Pressures - Expansion Valve (TXV)

TSA*S4	-036	-042	-048	-060-1	-060-2
°F (°C)*	Liquid / Vapor	Liquid / Vapor	Liquid / Vapor	Liquid / Vapor	Liquid / Vapor
65 (18)	253 / 134	250 / 135	240 / 130	247 / 129	242 / 130
70 (21)	274 / 135	268 / 137	257 / 131	265 / 130	266 / 131
75 (24)	293 / 136	288 / 138	278 / 132	286 / 131	286 / 132
80 (27)	315 / 137	310 / 139	299 / 133	310 / 132	309 / 133
85 (29)	338 / 139	332 / 140	323 / 134	330 / 132	332 / 134
90 (32)	361 / 139	356 / 140	344 / 135	353 / 133	357 / 135
95 (35)	385 / 141	381 / 141	369 / 136	375 / 134	381 / 136
100 (38)	410 / 142	406 / 143	394 / 137	400 / 136	407 / 137
105 (41)	436 / 143	432 / 143	418 / 139	426 / 137	433 / 138
110 (43)	463 / 145	459 / 145	446 / 140	451 / 139	459 / 140
115 (45)	491 / 146	490 / 145	477 / 141	482 / 141	488 / 141

Determining Charge Method

START: Determine the correct charge method:

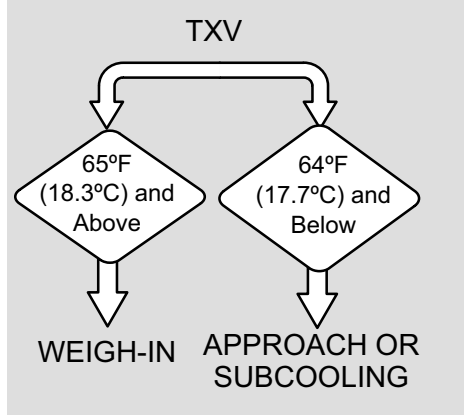

WHEN TO CHARGE?

- Warm weather best
- Can charge in colder weather

CHARGE METHOD? Determine by:

- Outdoor ambient temperature

REQUIREMENTS:

- Sufficient heat load in structure
- Indoor temperature between 70-80°F (21-26°C)
- Manifold gauge set connected to unit
- Thermometers:
 - to measure outdoor ambient temperature
 - to measure liquid line temperature
 - to measure vapor line temperature

FIGURE 10

Weigh in Charging Method

- 1-. Confirm proper airflow across coil as (see page 9).
- 2-. Check Liquid and Vapor line pressures.
- 3-. Compare unit pressures with Normal Operating Pressures table 2.

NOTE - Table 2 is a general guide. Expect minor pressures variations. Significant differences may mean improper charge or other system problem.)

- 4-. Recover the refrigerant from the unit.
- 5-. Conduct leak check; evacuate as previously outlined.

- 6-. Weigh in the unit nameplate charge plus any charge required for linesets differences from 15 feet and any extra indoor unit match-up amount. (If weighing facilities are not available, use the subcooling method.)

Table 3
Charge per Line Set Lengths

Liquid Line Set Diameter	Ounces per 5 feet (g per 1.5 m) adjust from 15 feet (4.6 m) line set*
3/8 in. (9.5 mm)	3 ounce per 5 ft. (85 g per 1.5 m)

*NOTE - *If line length is greater than 15 ft. (4.6 m), add this amount. If line length is less than 15 ft. (4.6 m), subtract this amount.*

Approach TXV Charge Procedure

START: Measure outdoor ambient temperature

USE WEIGH-IN METHOD
Weigh-in or remove refrigerant based upon line length

ABOVE

Outdoor Ambient 65°F (18°C)?

BELOW

- 1-. Confirm proper airflow across coil using figure 9 on page 9.
- 2-. Check liquid and vapor line pressures and compare unit pressures with Normal Operating Pressures listed in table 2. (Table 2 is a general guide. Expect minor pressures variations. Significant differences may mean improper charge or other system problem.)
- 3-. Use APPROACH to correctly charge unit or to verify the charge is correct.

APPROACH TXV

If value is greater than shown (high approach), add refrigerant; if less than shown (liquid temp too close to ambient temp, low approach), remove refrigerant.

If refrigerant added or removed, retest to confirm that unit is properly charged

APPROACH METHOD

- 4-. Set thermostat to call for heat (must have a cooling load between 70-80°F (21-26°C)
- 5-. Connect gauge set
- 6-. When heat demand is satisfied, set thermostat to call for cooling
- 7-. Allow temperatures and pressures to stabilize
- 8-. Record outdoor ambient temperature AMB° = _____
- 9-. Record line temp. LIQ° = _____
- 10-. Subtract to determine approach (APP°):
- 11-. LIQ° _____ - AMB° _____ = APP° _____
- 12-. Compare results with table to the left

APP° (Approach) Values(F: +/-1.0°; [C: +/-0.6°])

	Models			
°F (°C)*	-036	-042	-048	-060
Any	15 (8.3)	10 (5.6)	6 (3.3)	9 (5.0)

*Temperature of air entering outdoor coil

FIGURE 11

Subcooling TXV Charge Procedure

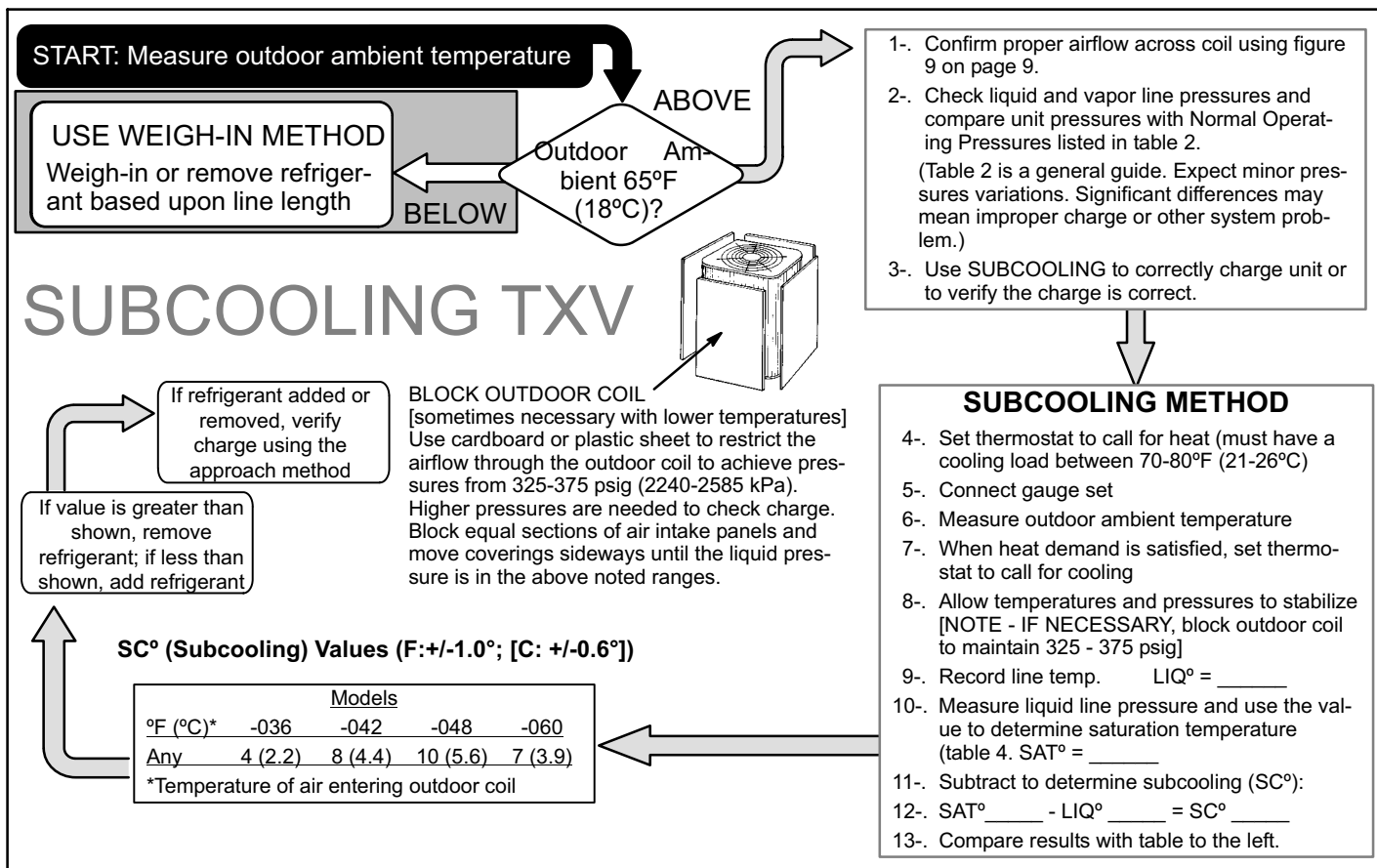

FIGURE 12

Table 4
HFC-410A Temperature (°F) - Pressure (Psig)

°F	Psig	°F	Psig	°F	Psig	°F	Psig	°F	Psig	°F	Psig	°F	Psig	°F	Psig
32	100.8	48	137.1	63	178.5	79	231.6	94	290.8	110	365.0	125	445.9	141	545.6
33	102.9	49	139.6	64	181.6	80	235.3	95	295.1	111	370.0	126	451.8	142	552.3
34	105.0	50	142.2	65	184.3	81	239.0	96	299.4	112	375.1	127	457.6	143	559.1
35	107.1	51	144.8	66	187.7	82	242.7	97	303.8	113	380.2	128	463.5	144	565.9
36	109.2	52	147.4	67	190.9	83	246.5	98	308.2	114	385.4	129	469.5	145	572.8
37	111.4	53	150.1	68	194.1	84	250.3	99	312.7	115	390.7	130	475.6	146	579.8
38	113.6	54	152.8	69	197.3	85	254.1	100	317.2	116	396.0	131	481.6	147	586.8
39	115.8	55	155.5	70	200.6	86	258.0	101	321.8	117	401.3	132	487.8	148	593.8
40	118.0	56	158.2	71	203.9	87	262.0	102	326.4	118	406.7	133	494.0	149	601.0
41	120.3	57	161.0	72	207.2	88	266.0	103	331.0	119	412.2	134	500.2	150	608.1
42	122.6	58	163.9	73	210.6	89	270.0	104	335.7	120	417.7	135	506.5	151	615.4
43	125.0	59	166.7	74	214.0	90	274.1	105	340.5	121	423.2	136	512.9	152	622.7
44	127.3	60	169.6	75	217.4	91	278.2	106	345.3	122	428.8	137	519.3	153	630.1
45	129.7	61	172.6	76	220.9	92	282.3	107	350.1	123	434.5	138	525.8	154	637.5
46	132.2	62	175.4	77	224.4	93	286.5	108	355.0	124	440.2	139	532.4	155	645.0
47	134.6			78	228.0			109	360.0			140	539.0		

IV - MAINTENANCE

⚠ WARNING



Electric shock hazard. Can cause injury or death. Before attempting to perform any service or maintenance, turn the electrical power to unit OFF at disconnect switch(es). Unit may have multiple power supplies.

Maintenance and service must be performed by a qualified installer or service agency. At the beginning of each cooling season, the system should be checked as follows:

- 1 - Clean and inspect outdoor coil. The coil may be flushed with a water hose. Make sure power is off before cleaning.

The outdoor coil is protected by an inner mesh screen and a wire cage (see figure 13).

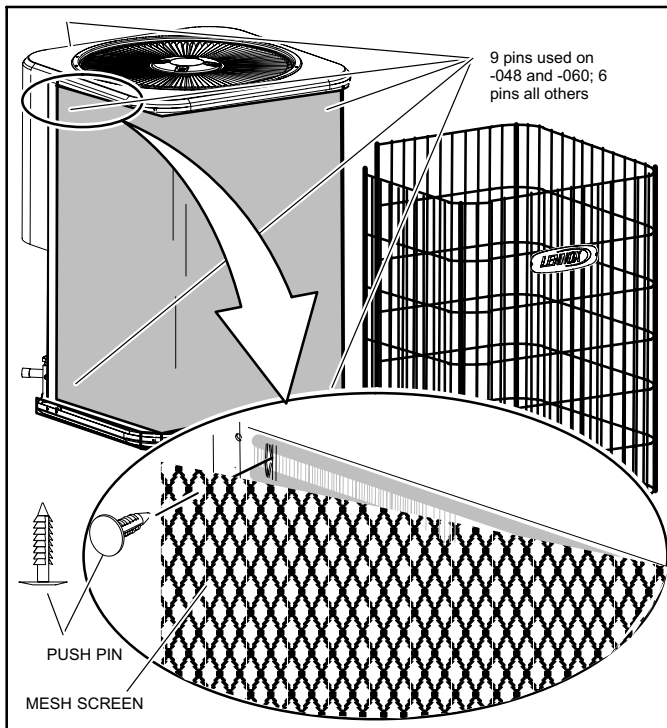

FIGURE 13

If debris has collected between the mesh screen and the coil and cannot be dislodged by spraying unpressurized water from inside coil surface to the outside, the mesh may be removed by first removing the top of the unit which will allow for removal of the wire cage.

Then, using pliers to grip the head of the push pins, pull straight out to extract the push pins along one side of the coil. If necessary, remove the push pins along the back of the unit; it is usually unnecessary to fully remove the inner mesh screen.

Drape the mesh screen back and wash the coil. When all the debris has been removed from the coil, reinstall the mesh screen by positioning it in its original position and reinserting the push pin. No tool is required to push the pin back into the same slot in the fins.

If the push pin is loose and tends not to stay in place, brush the fins with a fin brush (22 fins/in). Line up the push pin a couple fins to the right or left of the original hole and re-insert the pin.

- 2 - Condenser fan motor is prelubricated and sealed. No further lubrication is needed.
- 3 - Visually inspect connecting lines and coils for evidence of oil leaks.
- 4 - Check wiring for loose connections.
- 5 - Check for correct voltage at unit (unit operating).
- 6 - Check amp-draw condenser fan motor.
Unit nameplate _____ Actual _____ .

NOTE - If owner complains of insufficient cooling, the unit should be gauged and refrigerant charge checked. Refer to section on refrigerant charging in this instruction.

Indoor Coil

- 1 - Clean coil, if necessary.
- 2 - Check connecting lines and coils for evidence of oil leaks.
- 3 - Check the condensate line and clean it if necessary.

Indoor Unit

- 1 - Clean or change filters.
- 2 - Adjust blower speed for cooling. Measure the pressure drop over the coil to determine the correct blower CFM. Refer to the unit information service manual for pressure drop tables and procedure.
- 3 - *Belt Drive Blowers* - Check belt for wear and proper tension.
- 4 - Check all wiring for loose connections
- 5 - Check for correct voltage at unit (blower operating).
- 6 - Check amp-draw on blower motor
Unit nameplate _____ Actual _____ .

V - WIRING DIAGRAMS AND SEQUENCE OF OPERATION

TSA*S4 Y & G Voltage

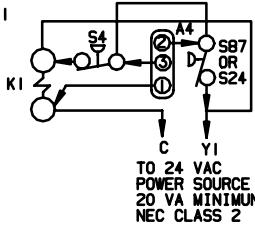
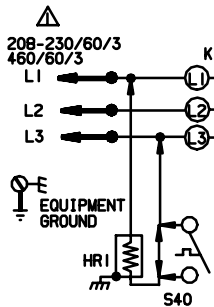
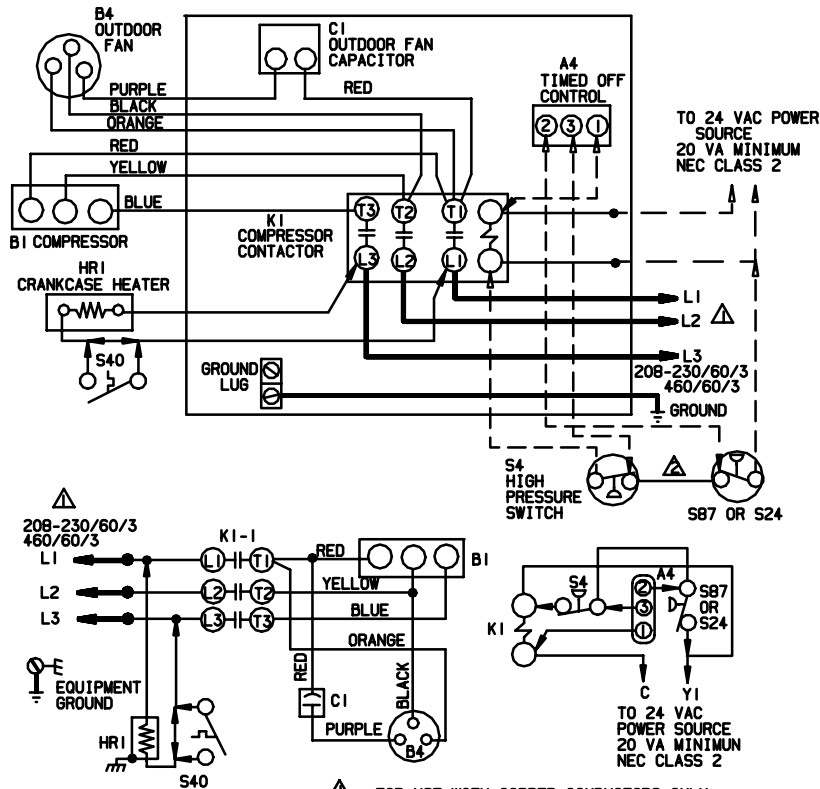

KEY	DESCRIPTION
A4	CONTROL-TIMED OFF
B1	COMPRESSOR
B4	MOTOR-OUTDOOR FAN
C1	CAPACITOR-OUTDOOR FAN
HRI	HEATER-COMPRESSOR
K1	CONTACTOR-COMPRESSOR
S4	SWITCH-HIGH PRESSURE
S24	SWITCH-LOSS OF CHARGE
S40	THERMOSTAT-CRANKCASE

⚠ FOR USE WITH COPPER CONDUCTORS ONLY. REFER TO UNIT RATING PLATE FOR MINIMUM CIRCUIT AMPACITY AND MAXIMUM OVER-CURRENT PROTECTION SIZE

⚡ JUMPER IS USED WHEN TOC IS NOT USED

WARNING-
ELECTRIC SHOCK HAZARD, CAN CAUSE INJURY OR DEATH. UNIT MUST BE GROUND IN ACCORDANCE WITH NATIONAL AND LOCAL CODES.

— LINE VOLTAGE FIELD INSTALLED
- - - CLASS II VOLTAGE FIELD INSTALLED

1105	Supersedes Form No.
	New Form No.
	535,274W

© 2005 Litho U.S.A.

NOTE- The thermostat used may be electromechanical or electronic.
NOTE- Transformer in indoor unit supplies power (24 VAC) to the thermostat and outdoor unit controls.

COOLING:

- 1- Cooling demand initiates at Y1 in the thermostat.
- 2- 24VAC from indoor unit (Y1) energizes contactor K1.
- 3- K1-1 N.O. closes, energizing compressor (B1) and outdoor fan motor (B4).

END OF COOLING DEMAND:

- 4- Cooling demand is satisfied. Terminal Y1 is de-energized.
- 5- Compressor contactor K1 is de-energized.
- 6- K1-1 opens and compressor (B1) and outdoor fan motor (B4) are de-energized and stop immediately.

TSA*S4 J Voltage

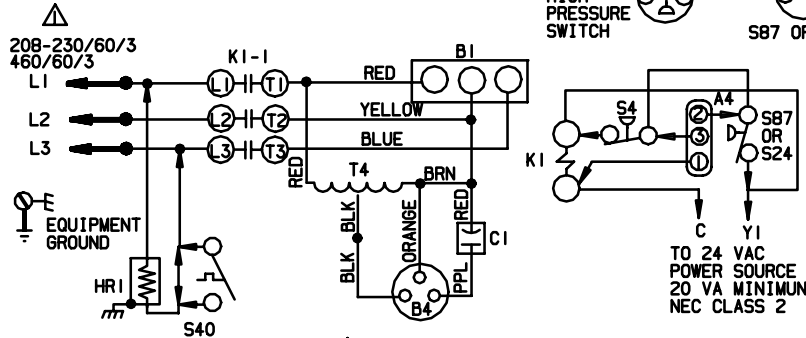
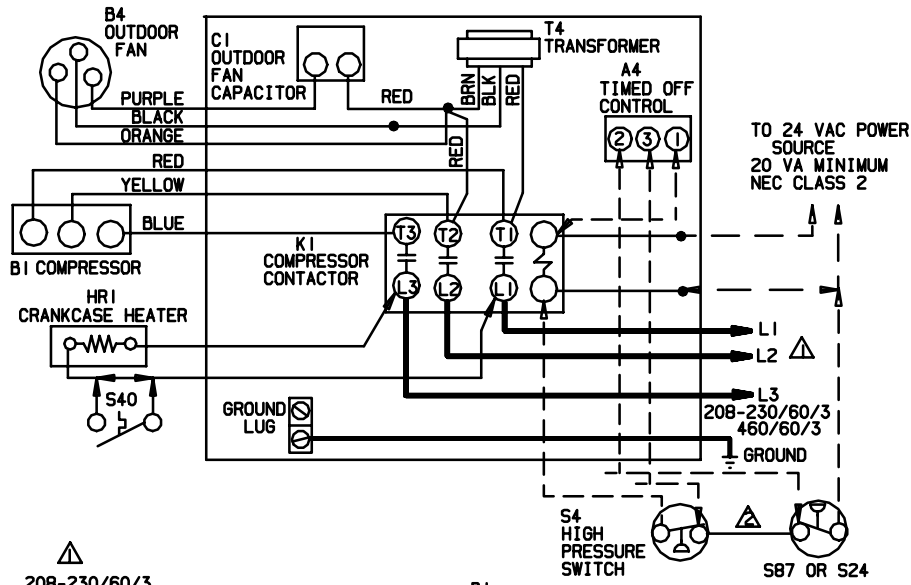

KEY	DESCRIPTION
A4	CONTROL-TIMED OFF
B1	COMPRESSOR
B4	MOTOR-OUTDOOR FAN
C1	CAPACITOR-OUTDOOR FAN
HR1	HEATER-COMPRESSOR
K1-1	CONTACTOR-COMPRESSOR
S4	SWITCH-HIGH PRESSURE
S24	SWITCH-LOSS OF CHARGE
S40	THERMOSTAT-CRANKCASE
T4	TRANSFORMER-BLWR MTR

⚠ FOR USE WITH COPPER CONDUCTORS ONLY. REFER TO UNIT RATING PLATE FOR MINIMUM CIRCUIT AMPACITY AND MAXIMUM OVER-CURRENT PROTECTION SIZE

⚠ JUMPER IS USED WHEN TOC IS NOT USED

WARNING- ELECTRIC SHOCK HAZARD, CAN CAUSE INJURY OR DEATH. UNIT MUST BE GROUND IN ACCORDANCE WITH NATIONAL AND LOCAL CODES.

———— LINE VOLTAGE FIELD INSTALLED
 - - - - CLASS II VOLTAGE FIELD INSTALLED

0106	Supersedes Form No.
New Form No.	
535, 332W	

© 2006

Litho U.S.A.

NOTE- The thermostat used may be electromechanical or electronic.

NOTE- Transformer in indoor unit supplies power (24 VAC) to the thermostat and outdoor unit controls.

COOLING:

- 1- Cooling demand initiates at Y1 in the thermostat.
- 2- 24VAC from indoor unit (Y1) energizes contactor K1.
- 3- K1-1 N.O. closes, energizing compressor (B1) and outdoor fan motor (B4).

END OF COOLING DEMAND:

- 4- Cooling demand is satisfied. Terminal Y1 is de-energized.
- 5- Compressor contactor K1 is de-energized.
- 6- K1-1 opens and compressor (B1) and outdoor fan motor (B4) are de-energized and stop immediately.