

GHR32Q/V SERIES UNITS

This manual contains information pertaining to GHR32-1 through -6 model units. GHR32 series units are high-efficiency horizontal or down flow gas furnaces manufactured with Lennox DuralokPlus™ aluminized and stainless steel clamshell-type heat exchangers. GHR32Q units are available in heating input capacities of 50,000 to 120,000 Btuh (14.7 to 35.2 kW) and cooling applications from 2 through 5 tons (7.0 through 17.6 kW). GHR32V units are available in heating capacities of 75,000 and 100,000 Btuh (22.0 and 29.3 kW) and 3 and 5 tons (10.5 and 17.5) for cooling. Refer to Engineering Handbook for proper sizing.

Units are factory equipped for use with natural gas. A kit is available for conversion to LPG operation. GHR32-1 through -4 units are equipped with the Lennox SureLight silicon nitride ignition system. GHR32-5 units are equipped with the two stage (V models will have the variable speed control) integrated control board. Each GHR32 unit meets the California Nitrogen Oxides (NO_x) Standards and California Seasonal Efficiency requirements. The gas valve is redundant to assure safety shut-off as required by A.G.A. and C.G.A.

The heat exchanger, burners and manifold assembly can be removed for inspection and service. The maintenance section gives a detailed description on how this is done.

Information contained in this manual is intended for use by qualified service technicians only. All specifications are subject to change. Procedures outlined in this manual are presented as a recommendation only and do not supersede or replace local or state codes.



DOWN FLOW POSITION

GHR32Q MODEL SHOWN

TABLE OF CONTENTS

General	1	VII Wiring Diagram and Sequence of Operation	54
Specifications Q Models	2	GHR32Q-1	54
Blower performance Q Models	3	GHR32Q-3	55
Specifications V Models	4	GHR32Q-5	57
Blower performance V Models	5	GHR32V-1	59
Parts Arrangement	7	GHR32V-3	60
I Unit Components	8	GHR32V-4	61
II Placement and Installation	41	GHR32V-5	63
III Start Up	46	VIII Operating Flow Charts	65
IV Heating System Service Checks	47	IX Troubleshooting	76
V Typical Operating Characteristics	49	X Blower Control Board Jumper Summary	87
VI Maintenance	51		

SPECIFICATIONS GHR32Q MODELS

Model No.		GHR32Q2/3-50	GHR32Q3-75	GHR32Q4/5-100	GHR32Q4/5-120	
Input — Btuh (kW)	High Fire	50,000 (14.7)	72,000 (21.1)	100,000 (29.3)	118,000 (34.6)	
	Low Fire	34,000 (10.0)	51,000 (14.9)	68,000 (19.9)	81,600 (23.9)	
Output — Btuh (kW)	High Fire	47,000 (13.8)	67,000 (19.6)	93,000 (27.2)	111,000 (32.5)	
	Low Fire	31,600 (9.3)	47,000 (13.8)	63,000 (18.4)	75,900 (22.2)	
① A.F.U.E.		90.0%				
California Seasonal Efficiency		83.7%	83.9%	85.3%	84.0%	
② Exhaust pipe connection (PVC) diameter — in. (mm)		2 (51)				
② Intake pipe connection (PVC) diameter — in. (mm)		2 (51)				
Condensate drain connection (PVC) — in. (mm)		1/2 (12.7)				
Temperature rise range — °F (°C)	High Fire	30 - 60 (17 - 33)	40 - 70 (22 - 39)	45 - 75 (25 - 42)		
	Low Fire	25 - 55 (14 - 31)	35 - 65 (20 - 36)	40 - 70 (22 - 39)		
High static certified by (A.G.A./C.G.A.) — in wg. (Pa)		.50 (125)				
Gas Piping Size I.P.S. — in. (mm)		1/2 (12.7)				
Blower wheel nominal diameter x width	in.	10 x 8		11-1/2 x 9		
	mm	254 x 203		292 x 229		
③ Number and size of filters - in. (mm)		(1) 14 x 25 x 1 (356 x 635 x 25)		(1) 20 x 25 x 1 (508 x 635 x 25)		
Blower motor output — hp (W)		1/3 (249)	1/2 (373)	3/4 (560)		
Nominal cooling that can be added	Tons	2 to 3	2 to 3.5	3.5 to 5		
	kW	7.0 to 10.6	7.0 to 12.3	12.3 to 17.6		
Shipping weight — lbs. (kg) 1 package		147 (67)	155 (70)	196 (89)	205 (93)	
Electrical characteristics		120 volts — 60 hertz — 1 phase (less than 12 amps)				
Optional Accessories (Must Be Ordered Extra)						
LPG/Propane kit		59L81 (-1 and -2 models) 11M57 (-3 and later models)				
Down-Flow Additive Base		32K52		32K53		
Horizontal Support Frame Kit — Ship. Wt. - lbs. (kg.)		56J18 — 18 lbs. (8 kg)				
② Vent/ Intake Kits	Concentric Roof/Wall Termination Kits		60G77 - For 1 1/2 inch (38 mm) venting	33K97 - For 2 inch (51 mm) venting	60L46 - For 3 inch (76 mm) venting	
	Roof Termination Kits	For 2 inch (51 mm) venting	15F75			
		For 3 inch (76 mm) venting	Not Available	44J41		
	Wall Termination Kits	For 2 inch (51 mm) venting	15F74 (ring kit) - 22G44 (close couple) - 30G28 (WTK Close Couple) - 30G79 (WTKX close couple with extension riser)			Not Available
		For 3 inch (76 mm) venting	Not Available	44J40 (close couple) — 81J20 (WTK close couple)		
Twinning Kit		15L38 (all models)				
Condensate Drain Heat Cable		26K68 6 ft. (1.8 m) — 26K69 24 ft. (7.3 m) — 26K70 50 ft. (15.2 m)				
Heat Cable Tape		39G04 1/2 inch (13 mm) wide or 39G03 2 inch (51 mm) wide				

① Annual Fuel Utilization Efficiency based on U.S. DOE test procedures and FTC labeling regulations. Isolated combustion system rating for non-weatherized furnaces.

② Determine from venting tables proper intake and exhaust pipe size and termination kit required.

③ Cleanable polyurethane frame type filter.

HIGH ALTITUDE

No gas pressure adjustment is needed when operating from 0 to 4500 ft. (0 to 1372m). See table below for correct manifold pressure and prove switch for altitudes greater than 4500 ft. (1372m).

Model No.	Prove Switch	Manifold Pressure (outlet) in. w.g. (kPa)		
		4501 to 5500 ft. (1373 to 1676m)	5501 to 6500 ft. (1677 to 1981m)	6501 to 7500 ft. (1982 to 2286m)
GHR32-50 nat	no change	3.5 (0.87)	3.5 (0.87)	3.5 (0.87)
GHR32-75 nat	Kit #67K27	3.4 (0.85)	3.3 (0.82)	3.2 (0.80)
GHR32-100 nat				
GHR32-120 L.P.	no change	10.0 (2.49)	10.0 (2.49)	10.0 (2.49)
GHR32-50 L.P.				
GHR32-75 L.P.				
GHR32-100 L.P.	Kit #67K27	10.0 (2.49)	10.0 (2.49)	10.0 (2.49)
HGR32-120 L.P.				

BLOWER PERFORMANCE DATA Q MODELS

GHR32Q2/3-50 BLOWER PERFORMANCE													
External Static Pressure		Air Volume and Motor Watts at Specific Blower Taps											
		High			Medium-High			Medium-Low			Low		
in. w.g.	Pa	cfm	L/s	Watts	cfm	L/s	Watts	cfm	L/s	Watts	cfm	L/s	Watts
0	0	1480	700	640	1330	630	520	1070	505	435	900	425	355
.10	25	1430	675	615	1290	610	500	1050	495	420	880	415	346
.20	50	1380	650	595	1240	585	480	1040	490	400	870	410	330
.30	75	1320	625	570	1200	565	455	1010	475	380	850	400	320
.40	100	1260	595	545	1140	540	430	980	460	370	820	385	300
.50	125	1200	565	520	1080	510	410	930	440	320	790	375	280
.60	150	1100	520	500	1000	470	385	860	405	300	740	350	265
.70	175	1000	470	470	890	420	370	750	355	290	660	310	250
.80	200	800	380	440	700	330	340	590	280	280	550	260	240

NOTE — All air data is measured external to unit with air filter in place.

GHR32Q3-75 BLOWER PERFORMANCE													
External Static Pressure		Air Volume and Motor Watts at Specific Blower Taps											
		High			Medium-High			Medium-Low			Low		
in. w.g.	Pa	cfm	L/s	Watts	cfm	L/s	Watts	cfm	L/s	Watts	cfm	L/s	Watts
0	0	1650	780	720	1540	725	585	1450	685	540	1230	580	450
.10	25	1590	750	660	1490	705	550	1400	660	505	1200	565	420
.20	50	1520	715	645	1430	675	520	1350	635	485	1170	550	405
.30	75	1440	680	630	1370	645	490	1300	615	450	1130	535	390
.40	100	1370	645	610	1300	615	470	1240	585	430	1090	515	370
.50	125	1300	615	590	1240	585	450	1170	550	410	1040	490	330
.60	150	1210	570	560	1170	550	430	1100	520	375	970	460	320
.70	175	1120	530	540	1080	510	410	1020	480	350	890	420	280
.80	200	1020	480	515	980	460	380	900	425	325	750	355	260
.90	225	880	415	500	820	385	350	750	355	300	600	285	240

NOTE — All air data is measured external to unit with air filter in place.

GHR32Q4/5-100 BLOWER PERFORMANCE																
External Static Pressure		Air Volume and Motor Watts at Specific Blower Taps														
		High			Medium-High			Medium			Medium-Low			Low		
in. w.g.	Pa	cfm	L/s	Watts	cfm	L/s	Watts	cfm	L/s	Watts	cfm	L/s	Watts	cfm	L/s	Watts
0	0	2530	1195	1360	2300	1085	1210	2030	960	1050	1780	840	885	1540	725	745
.10	25	2460	1160	1290	2250	1060	1140	2010	950	1010	1760	830	850	1530	720	730
.20	50	2380	1125	1270	2200	1040	1100	1990	940	990	1740	820	830	1520	715	720
.30	75	2310	1090	1250	2150	1015	1080	1950	920	970	1720	810	805	1510	715	710
.40	100	2250	1060	1200	2090	985	1060	1910	900	950	1690	800	790	1500	710	690
.50	125	2180	1030	1150	2020	955	1020	1870	880	910	1660	785	780	1480	700	670
.60	150	2100	990	1100	1960	925	980	1810	855	870	1620	765	760	1430	675	650
.70	175	2010	950	1070	1880	885	940	1750	825	855	1570	740	730	1380	650	630
.80	200	1910	900	1040	1800	850	920	1680	795	840	1500	710	710	1320	625	615
.90	225	1800	850	1010	1700	800	890	1580	745	800	1420	670	690	1240	585	600
1.00	250	1700	800	980	1600	755	870	1500	710	780	1320	625	670	1120	530	590

NOTE — All air data is measured external to unit with air filter in place.

GHR32Q4/5-120 BLOWER PERFORMANCE																
External Static Pressure		Air Volume and Motor Watts at Specific Blower Taps														
		High			Medium-High			Medium			Medium-Low			Low		
in. w.g.	Pa	cfm	L/s	Watts	cfm	L/s	Watts	cfm	L/s	Watts	cfm	L/s	Watts	cfm	L/s	Watts
0	0	2400	1135	1250	2270	1070	1140	2060	970	1010	1800	850	860	1560	735	720
.10	25	2350	1110	1220	2220	1050	1100	2040	965	980	1780	840	830	1550	730	705
.20	50	2290	1080	1200	2170	1025	1080	2000	945	960	1750	825	815	1540	725	685
.30	75	2220	1050	1180	2120	1000	1060	1960	925	940	1720	810	800	1520	715	675
.40	100	2150	1015	1130	2050	965	1020	1900	895	920	1680	795	770	1500	710	660
.50	125	2080	980	1100	1980	935	980	1850	875	880	1640	775	750	1460	690	650
.60	150	2000	945	1050	1910	900	940	1780	840	840	1590	750	720	1420	670	630
.70	175	1900	895	1010	1830	865	920	1710	805	810	1530	720	690	1380	650	610
.80	200	1800	850	980	1740	820	900	1630	770	790	1460	690	675	1320	625	595
.90	225	1700	800	960	1630	770	860	1540	725	770	1380	650	660	1250	590	580
1.00	250	1600	755	940	1530	720	840	1430	675	750	1300	615	640	1150	545	560

NOTE — All air data is measured external to unit with air filter in place.

SPECIFICATIONS GHR32V MODELS

Model No.		GHR32V3-75	GHR32V5-100
Input — Btuh (kW)	High Fire	72,000 (21.1)	100,000 (29.3)
	Low Fire	51,000 (14.9)	68,000 (19.9)
Output — Btuh (kW)	High Fire	67,000 (19.6)	93,000 (27.2)
	Low Fire	47,000 (13.8)	63,000 (18.4)
①A.F.U.E.		90.0%	90.0%
California Seasonal Efficiency		83.9	85.3
②Exhaust pipe connection (PVC) diameter — in. (mm)		2 (51)	
②Intake pipe connection (PVC) diameter — in. (mm)		2 (51)	
Condensate drain connection (PVC) — in. (mm)		1/2 (12.7)	
Temperature rise range — °F (°C)	High Fire	40 - 70 (22 - 39)	
	Low Fire	35 - 65 (19 - 36)	
High static certified by (A.G.A./C.G.A.) — in wg. (Pa)		.80 (200)	
Gas Piping Size I.P.S. — in. (mm)		1/2 (12.7)	
Blower wheel nominal diameter x width	in.	10 x 8	11-1/2 x 9
	mm	254 x 203	292 x 229
Blower motor output — hp (W)		1/2 (373)	1 (746)
③Number and size of filters - in. (mm)		(1) 14 x 25 x 1 (356 x 635 x 25)	(1) 20 x 25 x 1 (508 x 635 x 25)
Nominal cooling that can be added	Tons	2 to 3.5	3.5 to 5
	kW	7.0 to 12.3	12.3 to 17.6
Shipping weight — lbs. (kg) 1 package		160 (73)	201 (91)
Electrical characteristics		120 volts — 60 hertz — 1 phase (less than 12 amps)	
Optional Accessories (Must Be Ordered Extra)			
LPG/Propane kit		59L81	
Down-Flow Additive Base		32K52	32K53
Horizontal Support Frame Kit — Ship. Wt. - lbs. (kg.)		56J18 — 18 lbs. (8 kg)	
②Vent/ Intake Kits	Concentric Roof/Wall Termination Kits		60G77 - For 1 1/2 inch (38 mm) venting 33K97 - For 2 inch (51 mm) venting
	Roof Termination Kits	For 2 inch (51 mm) venting	15F75
		For 3 inch (76 mm) venting	44J41
	Wall Termination Kits	For 2 inch (51 mm) venting	15F74 (ring kit) 22G44 (close couple) 30G28 (WTK Close Couple) 30G79 (WTKX close couple w/ extension riser)
For 3 inch (76 mm) venting		44J40 (close couple) — 81J20 (WTK close couple)	
Condensate Drain Heat Cable		26K68 6 ft. (1.8 m) — 26K69 24 ft. (7.3 m) — 26K70 50 ft. (15.2 m)	
Heat Cable Tape		39G04 1/2 inch (13 mm) wide or 39G03 2 inch (51 mm) wide	

①Annual Fuel Utilization Efficiency based on U.S. DOE test procedures and FTC labeling regulations. Isolated combustion system rating for non-weatherized furnaces.

②Determine from venting tables proper intake and exhaust pipe size and termination kit required.

③Cleanable polyurethane frame type filter.

BLOWER PERFORMANCE DATA -1 through -3 V MODELS

GHR32V3-75 BLOWER PERFORMANCE																								
0 through 0.80 in. w.g. (0 Through 200 Pa) External Static Pressure Range																								
VSP2-1 Blower Control Factory Settings												Low Speed — 3												
												High Speed — 4												
												Heat Speed — 3												
“ADJUST” Jumper Setting	VSP Jumper Speed Positions																							
	“LOW” Speed (Cool, Low Heat Or Continuous Fan)								“HIGH” Speed (Cool)								“HEAT” Speed							
	1		2		3		4		1		2		3		4		1		2		3		4	
	cfm	L/s	cfm	L/s	cfm	L/s	cfm	L/s	cfm	L/s	cfm	L/s	cfm	L/s	cfm	L/s	cfm	L/s	cfm	L/s	cfm	L/s	cfm	L/s
NORM	875	415	940	445	985	465	1060	500	1070	505	1130	535	1270	600	1290	610	1090	515	1175	555	1285	605	1330	630
minus 15% less motor speed	750	355	795	375	850	400	915	430	900	425	940	445	1055	500	1120	530	940	445	995	470	1095	515	1180	555

NOTE — The effect of static pressure and filter resistance is included in the air volumes listed.

GHR32V5-100 BLOWER PERFORMANCE																								
0 through 0.80 in. w.g. (0 Through 200 Pa) External Static Pressure Range																								
VSP2-1 Blower Control Factory Settings												Low Speed — 2												
												High Speed — 4												
												Heat Speed — 1												
“ADJUST” Jumper Setting	VSP Jumper Speed Positions																							
	“LOW” Speed (Cool Or Continuous Fan)								“HIGH” Speed (Cool)								“HEAT” Speed							
	1		2		3		4		1		2		3		4		1		2		3		4	
	cfm	L/s	cfm	L/s	cfm	L/s	cfm	L/s	cfm	L/s	cfm	L/s	cfm	L/s	cfm	L/s	cfm	L/s	cfm	L/s	cfm	L/s	cfm	L/s
NORM	1100	520	1260	595	1445	680	1635	770	1670	790	1960	925	2165	1020	2285	1075	1640	775	1825	860	2150	1015	2315	1090
minus 15% less motor speed	935	440	1015	480	1195	565	1355	640	1335	630	1495	705	1690	800	1800	850	1360	640	1465	690	1770	835	1905	900

NOTE — The effect of static pressure and filter resistance is included in the air volumes listed.

BLOWER PERFORMANCE DATA -4 V MODELS

GHR32V3-75 BLOWER PERFORMANCE																								
0 through 0.80 in. w.g. (0 Through 200 Pa) External Static Pressure Range																								
VSP3-1 Blower Control Factory Settings												ADJUST - NORM												
												Heat Speed - 3												
												Cool Speed - 4												
“ADJUST” Jumper Positions	VSP Jumper Speed Positions																							
	“HEAT”																							
	Low Speed												High Speed											
	1		2		3		4		1		2		3		4									
cfm	L/s	cfm	L/s	cfm	L/s	cfm	L/s	cfm	L/s	cfm	L/s	cfm	L/s	cfm	L/s	cfm	L/s	cfm	L/s	cfm	L/s	cfm	L/s	
“NORM” (Normal)	875	415	940	445	985	465	1060	500	1090	515	1175	555	1285	605	1330	630								
☐ “—” (Minus) 15%	750	355	795	375	850	400	915	430	940	445	995	470	1095	515	1180	555								
“ADJUST” Jumper Positions	“COOL”																							
	Low Speed												High Speed											
	1		2		3		4		1		2		3		4									
	cfm	L/s	cfm	L/s	cfm	L/s	cfm	L/s	cfm	L/s	cfm	L/s	cfm	L/s	cfm	L/s	cfm	L/s	cfm	L/s	cfm	L/s	cfm	L/s
“NORM” (Normal)	875	415	940	445	985	465	1060	500	1070	505	1130	535	1270	600	1290	610								
☐ “—” (Minus) 15%	750	355	795	375	850	400	915	430	900	425	940	445	1055	500	1120	530								

☐ 15% lower motor speed than NORM jumper setting.

NOTE - The effect of static pressure and filter resistance is included in air volumes shown.

NOTE - Continuous Fan only speed is approximately 825 cfm (390 L/s) - non adjustable.

NOTE - Lennox Harmony II™ zone control applications - MAX CFM is determined by COOL jumper placement with a minimum of approximately 875 cfm (415 L/s) for all positions.

GHR32V5-100 BLOWER PERFORMANCE																								
0 through 0.80 in. w.g. (0 Through 200 Pa) External Static Pressure Range																								
VSP3-1 Blower Control Factory Settings												ADJUST - NORM												
												Heat Speed - 2												
												Cool Speed - 4												
“ADJUST” Jumper Positions	VSP Jumper Speed Positions																							
	“HEAT”																							
	Low Speed												High Speed											
	1		2		3		4		1		2		3		4									
cfm	L/s	cfm	L/s	cfm	L/s	cfm	L/s	cfm	L/s	cfm	L/s	cfm	L/s	cfm	L/s	cfm	L/s	cfm	L/s	cfm	L/s	cfm	L/s	
“NORM” (Normal)	1100	520	1260	595	1445	680	1635	770	1640	775	1825	860	2150	1015	2315	1090								
☐ “—” (Minus) 15%	935	440	1015	480	1195	565	1355	640	1360	640	1465	690	1770	835	1905	900								
“ADJUST” Jumper Positions	“COOL”																							
	Low Speed												High Speed											
	1		2		3		4		1		2		3		4									
	cfm	L/s	cfm	L/s	cfm	L/s	cfm	L/s	cfm	L/s	cfm	L/s	cfm	L/s	cfm	L/s	cfm	L/s	cfm	L/s	cfm	L/s	cfm	L/s
“NORM” (Normal)	1100	520	1260	595	1445	680	1635	770	1670	790	1960	925	2165	1020	2285	1075								
☐ “—” (Minus) 15%	935	440	1015	480	1195	565	1355	640	1335	630	1495	705	1690	800	1800	850								

☐ 15% lower motor speed than NORM jumper setting.

NOTE - The effect of static pressure and filter resistance is included in air volumes shown.

NOTE - Continuous Fan only speed is approximately 1050 cfm (495 L/s) - non adjustable.

NOTE - Lennox Harmony II™ zone control applications - MAX CFM is determined by COOL jumper placement with a minimum of approximately 1100 cfm (520 L/s) for all positions.

**GHR32V3-75-5 Blower Motor Performance
(For Static Pressure 0.0" to 0.8" w.g.)**

"Adjust" Jumper Setting	Blower Speed Adjustment Settings (Switches 5 and 6)															
	Cooling															
	Low								High							
	1		2		3		4		1		2		3		4	
cfm	L/s	cfm	L/s	cfm	L/s	cfm	L/s	cfm	L/s	cfm	L/s	cfm	L/s	cfm	L/s	
Norm	875	415	940	445	985	465	1060	500	1070	505	1130	535	1270	600	1290	610
— [†]	750	355	795	375	850	400	915	430	900	425	940	445	1055	500	1120	530

"Adjust" Jumper Setting	Blower Speed Adjustment Settings (Switches 7 and 8)															
	Heating															
	Low								High							
	1		2		3		4		1		2		3		4	
cfm	L/s	cfm	L/s	cfm	L/s	cfm	L/s	cfm	L/s	cfm	L/s	cfm	L/s	cfm	L/s	
Norm	945	446	1025	484	1125	531	1270	599	1080	510	1172	533	1286	607	1452	685
— [†]	803	379	871	411	956	451	1080	510	918	433	996	470	1093	516	1234	582

[†] 15% lower motor speed than NORM switch setting.

NOTE - The effect of static pressure and filter resistance is included in air volumes shown.

NOTE - Continuous Fan only speed is approximately 825 cfm (390 L/s) - non adjustable.

NOTE - Lennox Harmony II™ zone control applications - MAX CFM is determined by COOL switch setting with a minimum of approximately 875 cfm (415 L/s) for all positions.

**GHR32V5-100/125-5 Blower Motor Performance
(For Static Pressure 0.0" to 0.8" w.g.)**

"Adjust" Jumper Setting	Blower Speed Adjustment Settings (Switches 5 and 6)															
	Cooling															
	Low								High							
	1		2		3		4		1		2		3		4	
cfm	L/s	cfm	L/s	cfm	L/s	cfm	L/s	cfm	L/s	cfm	L/s	cfm	L/s	cfm	L/s	
Norm	1100	520	1260	595	1445	680	1635	770	1670	790	1960	925	2165	1020	2285	1075
— [†]	935	440	1015	480	1195	565	1355	640	1335	630	1495	705	1690	800	1800	850

"Adjust" Jumper Setting	Blower Speed Adjustment Settings (Switches 7 and 8)															
	Heating															
	Low								High							
	1*		2		3		4		1*		2		3		4	
cfm	L/s	cfm	L/s	cfm	L/s	cfm	L/s	cfm	L/s	cfm	L/s	cfm	L/s	cfm	L/s	
Norm	1100	520	1260	595	1445	680	1635	770	1640	775	1825	860	2150	1015	2315	1090
— [†]	935	440	1015	480	1195	565	1355	640	1360	640	1465	690	1770	835	1905	900

[†] 15% lower motor speed than NORM switch setting.

NOTE - The effect of static pressure and filter resistance is included in air volumes shown.

NOTE - Continuous Fan only speed is approximately 1050 cfm (495 L/s) - non adjustable.

NOTE - Lennox Harmony II™ zone control applications - MAX CFM is determined by COOL switch setting with a minimum of approximately 1100 cfm (520 L/s) for all positions.

GHR32Q-5 PARTS IDENTIFICATION (Downflow Application Shown)

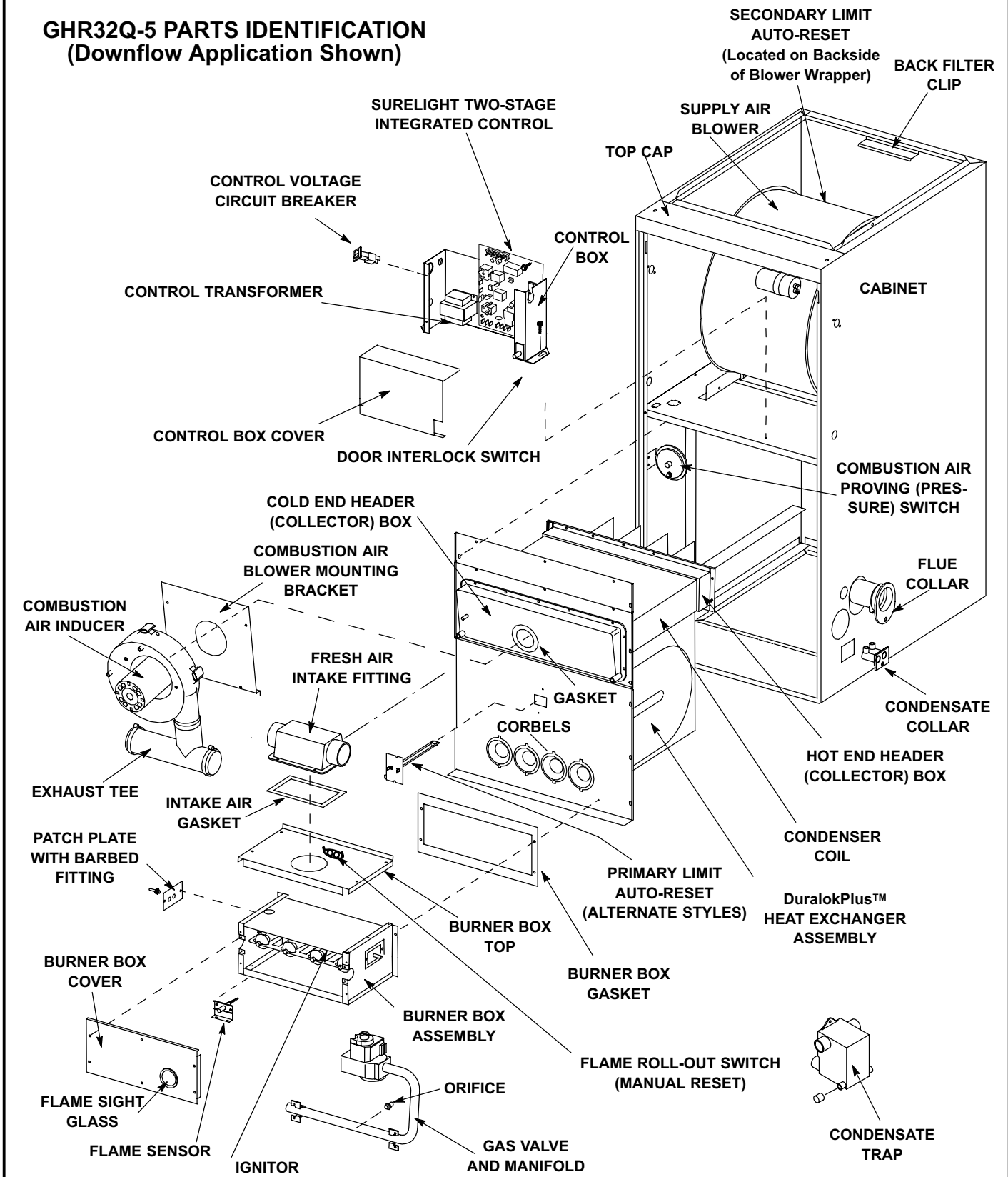

FIGURE 1

I-UNIT COMPONENTS

GHR32 unit components are shown in figure 1. The combustion air blower, gas valve and burners can be accessed by removing the burner access panel. The blower and control box can be accessed by removing the blower access door.

⚠ WARNING

Before attempting to perform any service or maintenance, turn the electrical power to unit OFF at disconnect switch

A-Make-Up Box (Figure 2)

⚠ WARNING

Unit must be grounded in accordance with national and local codes. Electric Shock Hazard. Can cause injury or death.

A field make-up box (see figure 2) is provided for line voltage wiring. Line voltage wiring to unit is done through the J96 jack from the field make-up box to plug P96 from the control box. The box may be installed inside or outside the unit (see figures 3 and 4) and may be installed on the unit left or right side.

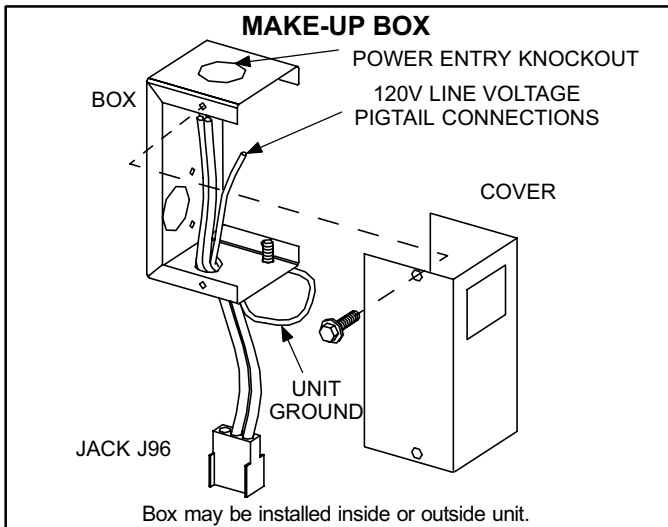

FIGURE 2

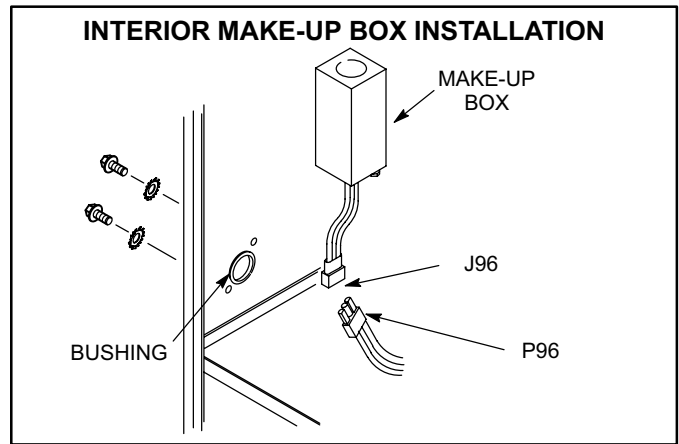

FIGURE 3

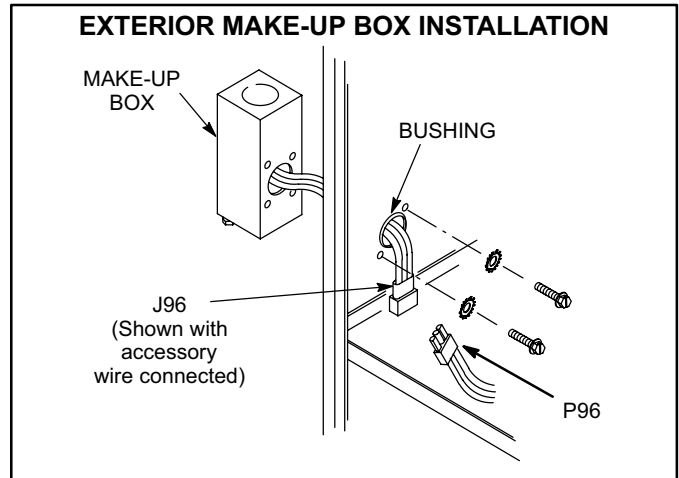

FIGURE 4

An accessory (brown) output wire is provided with the make-up box. The wire provides a 120V connection for optional accessories such as electronic air cleaner or humidifier. If used, the wire is field installed in J96 jack plug by inserting the pin of the brown wire into the open socket of the jack. See figure 5. 120V accessories rated up to 4 amps total may be connected to this wire. The neutral leg of the accessory is connected to the neutral white wire in the make-up box. The accessory terminal is energized whenever the indoor blower is in operation.

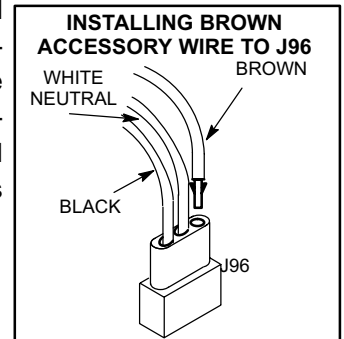

FIGURE 5

B-Control Box (Figure 6)
ELECTROSTATIC DISCHARGE (ESD)
Precautions and Procedures

⚠ CAUTION

Electrostatic discharge can affect electronic components. Take precautions during furnace installation and service to protect the furnace's electronic controls. Precautions will help to avoid control exposure to electrostatic discharge by putting the furnace, the control and the technician at the same electrostatic potential. Neutralize electrostatic charge by touching hand and all tools on an unpainted unit surface, such as the gas valve or blower deck, before performing any service procedure.

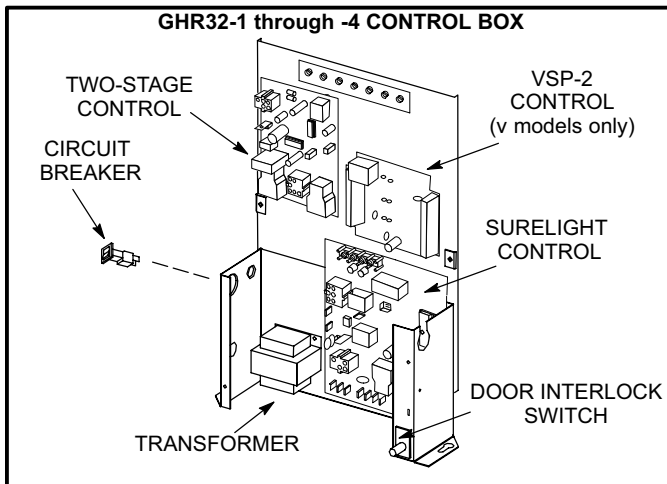

FIGURE 6

Unit transformer (T1), circuit breaker (CB8), SureLight control (A92), VSP-2 control (A24) and Two-stage control (A86) are located in the control box. In addition, a door interlock switch (S51) is located in the control box. Jackplugs and a "snap-off" terminal strip allow the control box to be easily removed for blower service.

1. Control Transformer (T1)

A transformer located in the control box provides power to the low voltage 24 volt section of the unit. Transformers on all models are rated 40VA with a 120V primary and a 24V secondary.

2. Circuit Breaker (CB8)

A 24V circuit breaker is also located in the control box. The switch provides overcurrent protection to the transformer (T1). The breaker is rated 3 amps at 32V. If the current exceeds this limit the breaker will trip and all unit operation will shut down. The breaker can be manually reset by pressing the button on the face (figure 7).

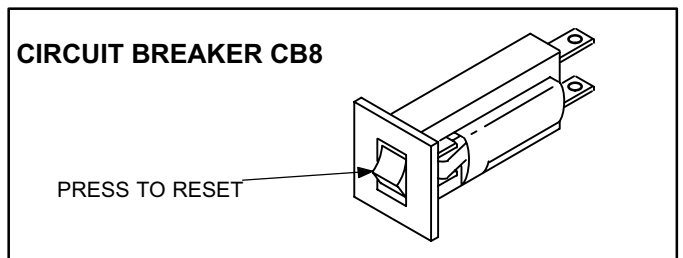

FIGURE 7

3. Door Interlock Switch (S51)

A door interlock switch rated 14 amps at 125VAC is located on the control box. The switch is wired in series with line voltage. When the blower door is removed the unit will shut down.

⚠ DANGER

Shock hazard.

Disconnect power before servicing. Control is not field repairable. If control is inoperable, simply replace entire control.

Can cause injury or death. Unsafe operation will result if repair is attempted.

4. SureLight Ignition System A92

All GHR32-1 through -4 units are equipped with the Lennox SureLight ignition system. The system consists of ignitor (figure 8) and ignition control board (figure 9 and table 3). The board and ignitor work in combination to ensure furnace ignition and ignitor durability. The SureLight integrated board controls all major furnace operations. Table 1 and 2 show jack plug terminal designations. shows control board terminations. The board also features two LED lights for troubleshooting and two accessory terminals rated at (1) one amp. See table 4 for troubleshooting diagnostic codes. Units equipped with the SureLight board can be used with either electronic or electro-mechanical thermostats without modification. The SureLight ignitor is made of durable silicon nitride. Ignitor longevity is also enhanced by voltage ramping by the control board. The board finds the lowest ignitor temperature which will successfully light the burner, thus increasing the life of the ignitor.

NOTE - Do not remove blower access panel to read Surelight LED lights. A sight glass is provided on the access panel for viewing.

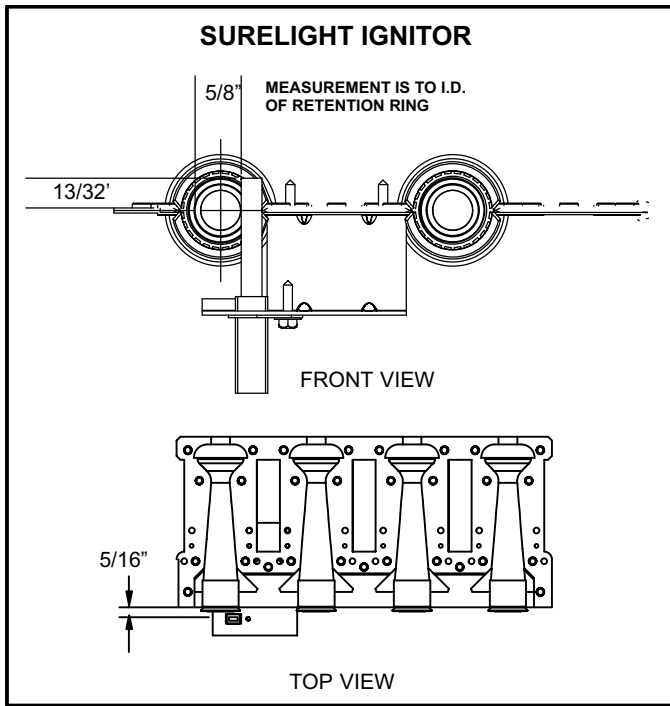

FIGURE 8

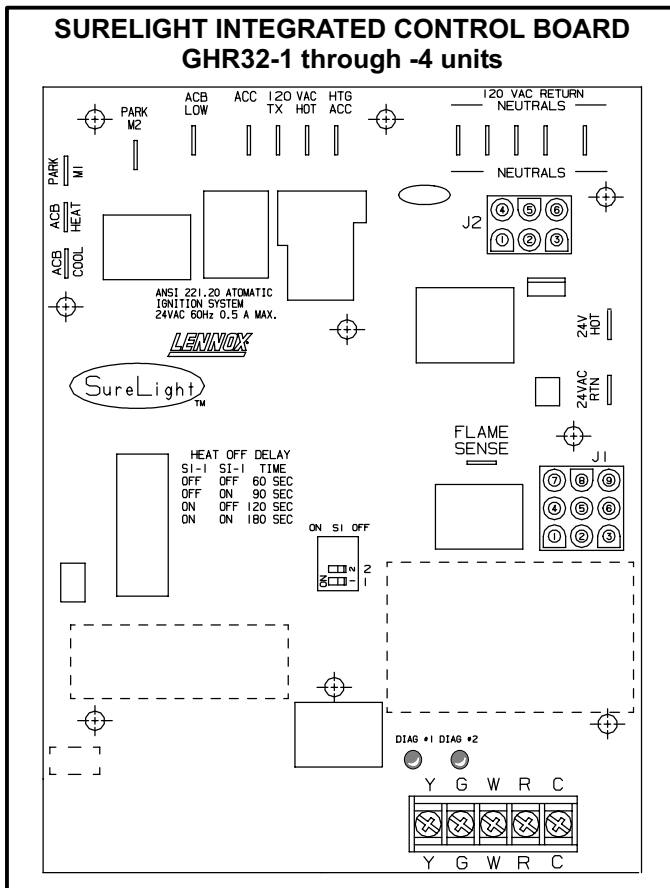

FIGURE 9

TABLE 1

SureLight BOARD J156 (J2) TERMINAL DESIGNATIONS	
PIN #	FUNCTION
1	Ignitor
2	Not Used
3	Ignitor Neutral
4	Combustion Air Blower Line Voltage
5	Not Used
6	Combustion Air Blower Neutral

TABLE 2

SureLight BOARD J58 (J1) TERMINAL DESIGNATIONS	
PIN #	FUNCTION
1	Primary Limit In
2	Gas Valve Common
3	Roll Out Switch Out
4	Gas Valve 24V
5	Pressure Switch In
6	Pressure Switch and Primary Limit Out
7	Not Used
8	Roll Out Switch In
9	Ground

TABLE 3

TERMINAL DESIGNATIONS	
ACB COOL	Blower - Cooling Speed (Line Volt)
ACB HEAT	Blower - Heating Speed (Line Volt)
PARK	Alternate Blower Speeds (Dead)
ACB LOW	Continuous Low Speed Blower
ACC	Accessory Terminal (Line Volt)
TX	120VAC Hot to Transformer
HOT	120VAC Hot Input
HTG ACC	Heat Only Accessory (Line Volt)
NEUTRALS	120VAC Neutrals
24VAC HOT	24VAC Hot from Transformer
24VAC RTN	24VAC Return from Transformer
FLAME SENSE	Flame Sense Terminal

TABLE 4

DIAGNOSTIC CODES		
MAKE SURE TO ID LED'S CORRECTLY: REFER TO INSTALLATION INSTRUCTIONS FOR CONTROL BOARD LAYOUT.		
LED #1	LED #2	DESCRIPTION
SIMULTANEOUS SLOW FLASH	SIMULTANEOUS SLOW FLASH	Power - Normal operation Also signaled during cooling and continuous fan.
SIMULTANEOUS FAST FLASH	SIMULTANEOUS FAST FLASH	Normal operation - signaled when heating demand initiated at thermostat.
SLOW FLASH	ON	Primary or Secondary limit open. Limit must close within 3 minutes or board goes into one hour limit Watchguard.
OFF	SLOW FLASH	Watchguard pressure switch - 5 minutes. Pressure switch open or has opened 5 times during a single call for heat; OR: Blocked inlet/exhaust vent; OR: Condensate line blocked; OR: Pressure switch closed prior to activation of combustion air blower.
ALTERNATING SLOW FLASH	ALTERNATING SLOW FLASH	Watchguard 60 minute delay - burners fail to ignite.
SLOW FLASH	OFF	Flame sensed without gas valve energized.
ON	SLOW FLASH	Rollout switch open. OR: 9 pin connector improperly attached.
ON ON OFF	ON OFF ON	Circuit board failure or control wired incorrectly.
FAST FLASH	SLOW FLASH	Main power polarity reversed. Switch line and neutral.
SLOW FLASH	FAST FLASH	Low flame signal. Measures below .61 microAmps. Replace flame sense rod.
ALTERNATING FAST FLASH	ALTERNATING FAST FLASH	Improper main ground or line voltage below 75 volts; OR: Broken ignitor; OR: Open ignitor circuit.

NOTE - Slow flash equals 1 Hz (one flash per second). Fast flash equals 3 Hz (three flashes per second). Drop out flame sense current < 0.21 microAmps

a-Electronic Ignition Figures 12 and 13

On a call for heat the SureLight control monitors the combustion air blower pressure switch. The control will not begin the heating cycle if the pressure switch is closed (bypassed). Once the pressure switch is determined to be open, the combustion air blower is energized. When the differential in the pressure switch is great enough, the pressure switch closes and a 15-second pre-purge begins. If the pressure switch is not proven within 2-1/2 minutes, the control goes into Watchguard-Pressure Switch mode for a 5-minute re-set period.

After the 15-second pre-purge period, the SureLight ignitor warms up for 20 seconds after which the gas valve opens for a 4-second trial for ignition. Units with control 97L48: ignitor stays energized during the trial or until flame is sensed. Units with control 56L83: ignitor stays energized for the first second of the 4-second trial. If ignition is not proved during the 4-second period, the control (97L48 or 56L83) will try four more times with an inter purge and warm-up time between trials of 35 seconds. After a total of five trials for ignition (including the initial trial), the control goes into Watchguard-Flame Failure mode. After a 60-minute reset period, the control will begin the ignition sequence again.

The SureLight control board has an added feature that prolongs the life of the ignitor. After a successful ignition, the SureLight control utilizes less power to energize the ignitor on successive calls for heat. The control continues to ramp down the voltage to the ignitor until it finds the lowest amount of power that will provide a successful ignition. This amount of power is used for 255 cycles. On the 256th call for heat, the control will again ramp down until the lowest power is determined and the cycle begins again.

b-Fan Time Control Q Models Only

The fan on time of 45 seconds is not adjustable. Fan off time (time that the blower operates after the heat demand has been satisfied) can be adjusted by flipping the dip switches located on the SureLight integrated control. The unit is shipped with a factory fan off setting of 90 seconds. Fan off time will affect comfort and is adjustable to satisfy individual applications. See figure 10.

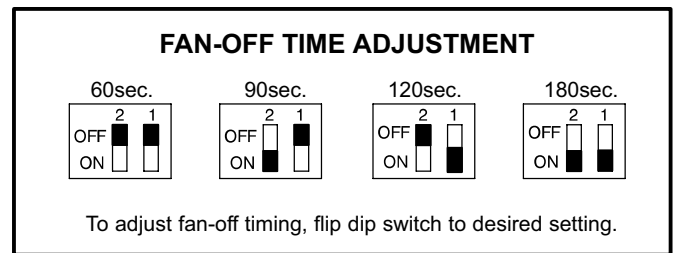

FIGURE 10

c-Flame Sensor

A flame sensor is located on the left side of the burner support. See figure 11. The sensor is mounted on a bracket in the burner support and the tip protrudes into the flame envelope of the left-most burner. The sensor is fastened to burner supports and can be removed for service without removing any part of the burners. During operation, flame is sensed by current passed through the flame and sensing electrode. The SureLight control allows the gas valve to remain open as long as flame signal is sensed.

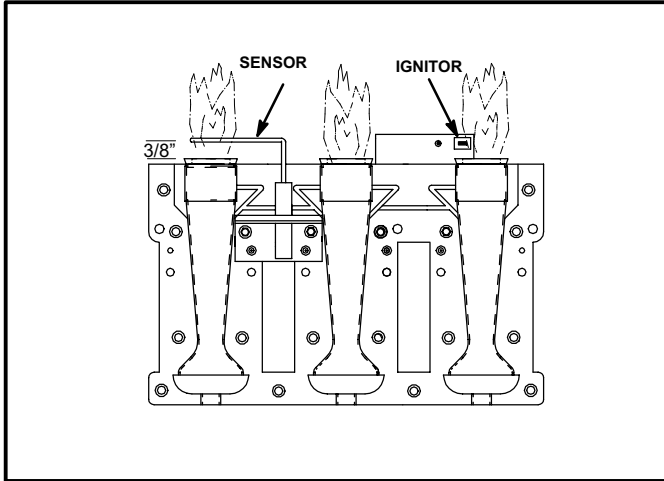

FIGURE 11

NOTE - The GHR32 furnace contains electronic components that are polarity sensitive. Make sure that the furnace is wired correctly and is properly grounded.

5. Two-Stage Control (A86)

All GHR32-1 through -4 units are equipped with a two-stage control board. Two different boards have been used. Boards 43K9001 and 29M9201 (figure 14) are identical, except the 9 pin connector on 43K9001 is replaced by two relays with quick connect terminals on board 29M9201. The two-stage board acts as a go between from the indoor thermostat to the SureLight ignition board. The board can be utilized in three modes: with a SINGLE-STAGE thermostat, a TWO-STAGE thermostat or with a second-stage (high fire) delay called W2 TIMED. The two-stage board is equipped with a jumper (see figure 14) which changes operating modes and a jumper which adjusts second-stage heat delay during W2 TIMED mode.

NOTE-The mode of operation jumper on the two-stage control board is factory set in the "TWO-STAGE" position.

While in the single-stage thermostat mode (one-stage jumper setting), the unit will always operate on second-stage heat. The combustion air blower (B6) will operate on high speed and indoor blower (B3) will operate on heating speed. While in the two-stage thermostat mode the unit will operate on first-stage heat (low fire). The combustion air blower (B6) and indoor blower will operate on low speed. The unit will switch to second-stage heat (high fire) on call from the indoor thermostat W2. While in the W2 TIMED mode (factory setting 8 minutes) the unit will fire on first-stage heat (low fire) with the combustion air blower (B6) and indoor blower (B3) operating on low speed. After a set time delay the unit switches to second-stage heat (high fire). The combustion air blower and indoor blower also switch to second-stage heat mode.

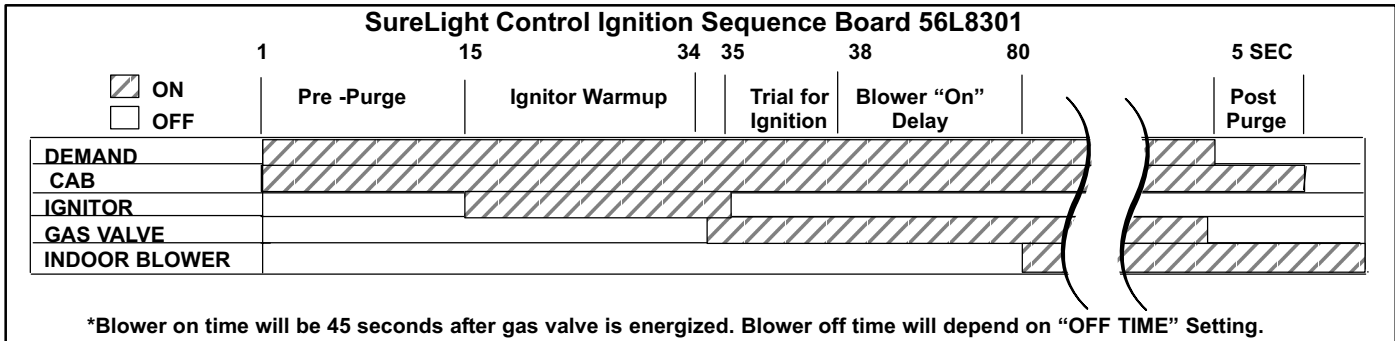

FIGURE 12

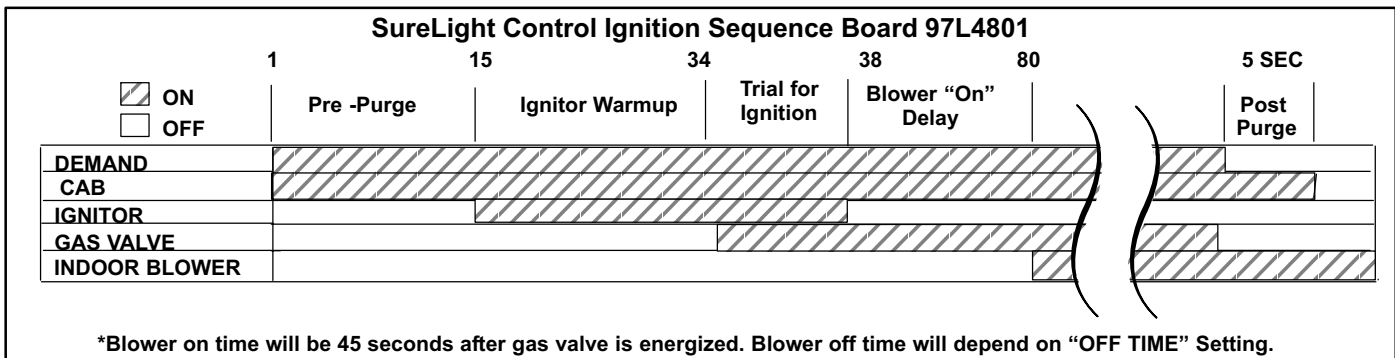

FIGURE 13

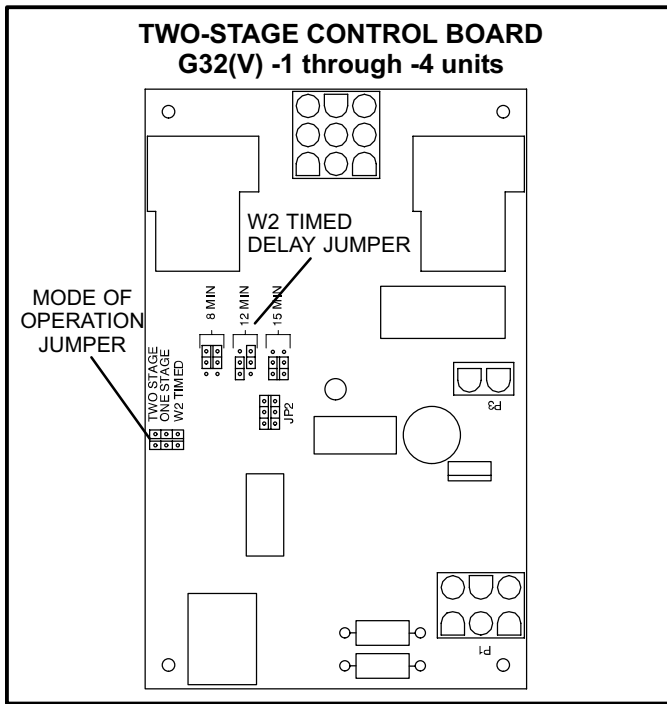

FIGURE 14

6.VSP2-1 Blower Control Board (A24) -1 through -3 V Models only

GHR32V-1 through -3 units are equipped with a variable speed motor that is capable of maintaining a specified CFM throughout the external static range. The unit uses the VSP2-1 variable speed control board, located in the blower compartment, which controls the blower speed and provides diagnostic LEDs. The control has a non-adjustable, factory preset "ON" fan timing delay and an adjustable "OFF" fan timing delay (see figure 17).

The VSP2-1 also senses limit trip condition and turns on the blower. The GHR32 primary limit switch is located in the middle of the vestibule wall and the secondary limit switch is located in the blower compartment. When excess heat is sensed in the heat exchanger, or blower compartment, the respective switch will open and interrupt the current to the gas valve, while at the same time the VSP2-1 energizes the blower on heating speed. The limit automatically resets when the unit temperature returns to normal and the blower is de-energized.

Diagnostic LEDs located on the VSP2-1 control board are provided to aid in identifying the unit's mode of operation. Certain scenarios will arise depending on the jumper positions. Refer to figure 15 for identification.

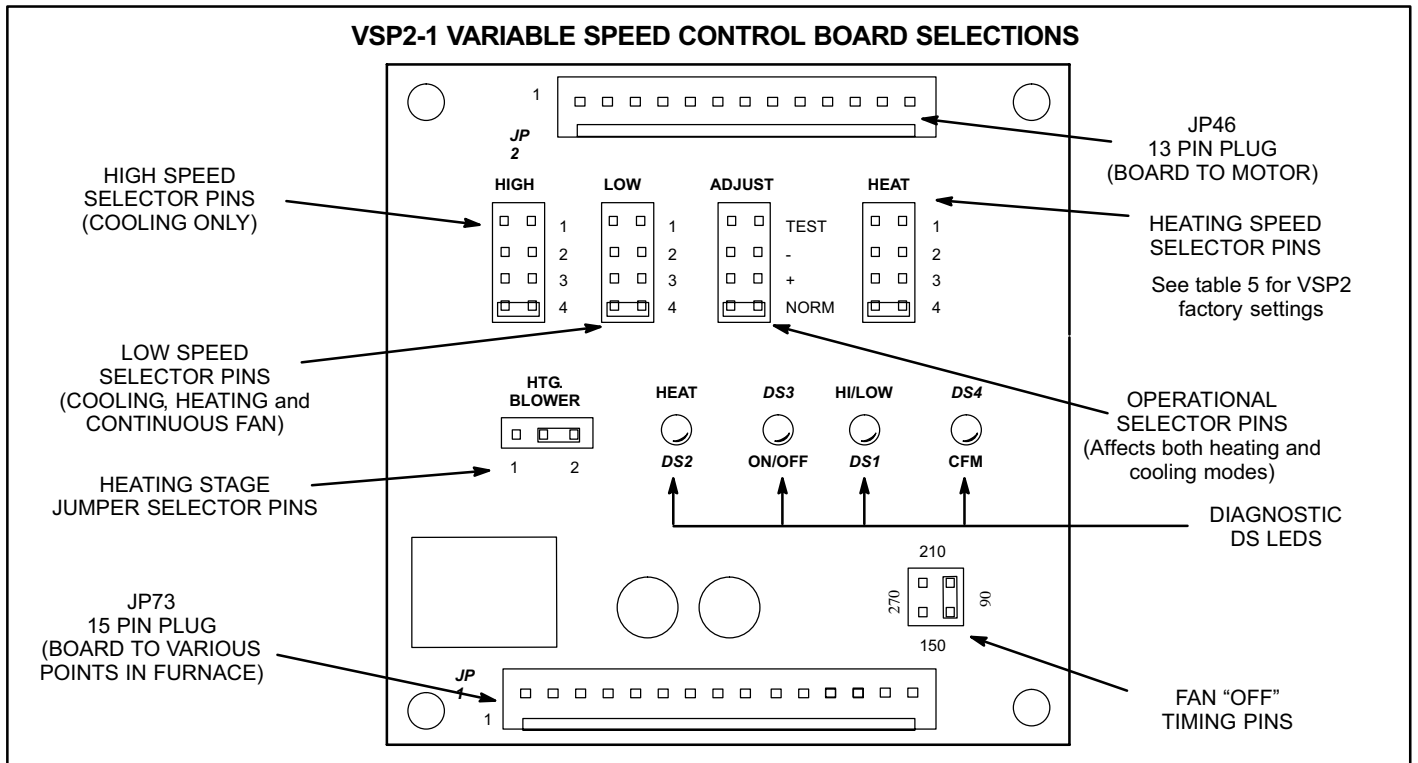

FIGURE 15

⚠ IMPORTANT

24 VAC half wave rectified (DC pulse), when measured with a meter, may appear as a lower or higher voltage depending on the make of the meter. Rather than attempting to measure the output voltage of the VSP2 board, see GHR32 BLOWER & VSP2 BLOWER CONTROL BOARD TROUBLESHOOTING FLOW CHART in the TROUBLESHOOTING section of this manual.

Diagnostic LED Lights

a - DS3 "ON/OFF"

ON/OFF-DS3 indicates there is a demand for the blower motor to run. When the **ON/OFF LED-DS3** is lit, a demand is being sent to the motor. In heating mode only, there is a 45 second fan "ON" delay in energizing **ON/OFF LED-DS3**. The light will not go off until adjustable fan "OFF" delay has expired.

If **ON/OFF LED-DS3** is on and both **HIGH/LOW LED-DS1** & **HEAT LED-DS2** are off, the motor will operate in low speed.

b - DS2 "HEAT"

If **HEAT LED-DS2** is on, the blower is running in the heat speed according to the "HEAT" jumper setting. The **HEAT LED-DS2** comes on instantaneous and switches off when the call for heat is satisfied.

NOTE-When the blower is in "OFF" delay mode, the motor runs at low speed, therefore the HEAT LED-DS2 is off. It switches off when the call for heat is satisfied.

c - DS1 "HI/LOW"

HIGH/LOW LED-DS1 indicates whether the blower is operating in high or low speed. When the light is off, the blower is running in low speed according to the "LOW" jumper setting. When **HIGH/LOW LED-DS1** is on, the blower is operating in high speed according to the "HIGH" jumper setting.

d - DS4 "CFM"

CFM LED-DS4 indicates the CFM the unit is operating, according to the jumper settings. The light flashes once for approximately every 100 CFM. For example, if the unit is operating at 1000 CFM, **CFM LED-DS4** will flash 10 times. If the CFM is 2050, **CFM LED-DS4** will flash 20 full times plus one fast or half flash.

At times the light may appear to flicker or glow. This takes place when the control is communicating with the motor between cycles. This is normal operation.

The appropriate speed according to application and CFM need is selected by moving jumper pins.

VSP2-1 BLOWER CONTROL BOARD (A24)

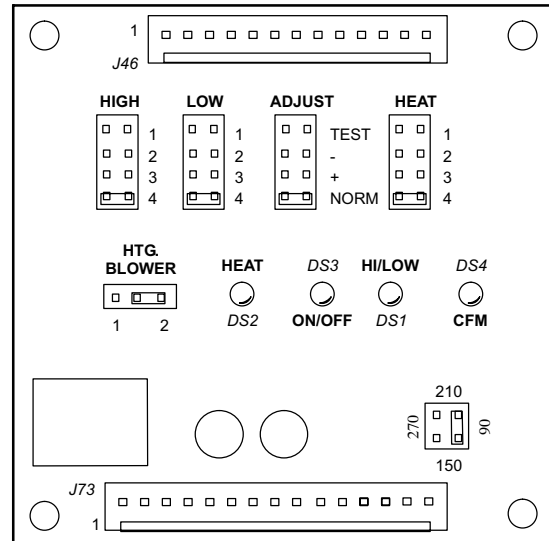

- J73**
- PIN 1 - C - 24 VAC common.
 - PIN 2 - G - Input signal from thermostat's fan signal.
 - PIN 3 - W2 - Input signal for second stage heat from the thermostat.
 - PIN 4 - DS - Input signal for the blower speed regulation.
 - PIN 5 - Limit - Input signal from the external limit.
 - PIN 6 - R - 24 VAC power to the thermostat.
 - PIN 7 - C - 24 VAC common.
 - PIN 8 - C - 24 VAC common.
 - PIN 9 - CI - Input signal from the fan limit control.
 - PIN 10 - CO - Output signal to the burner control.
 - PIN 11 - HT - Input signal from the fan limit control.
 - PIN 12 - ACC - 24 VAC accessory output.
 - PIN 13 - 24V - Input 24 VAC power for the VSP2-1.
 - PIN 14 - 24V - Input 24 VAC power for the VSP2-1.
 - PIN 15 - V - Input signal from the gas line.

- J46**
- PIN 1 - Heat - Heat speed input signal to the ICM2 motor.
 - PIN 2 - C - 24 VAC common.
 - PIN 3 - C - 24 VAC common.
 - PIN 4 - High Tap - High Speed programming input.
 - PIN 5 - Low Tap - Low speed programming input.
 - PIN 6 - On / Off - On / off output signal to the ICM2 motor.
 - PIN 7 - Adjust Tap - ICM2 mode selection.
 - PIN 8 - Hi / Low - Speed regulate input signal to the ICM2 motor.
 - PIN 9 - Hi / Low - Speed regulate input signal to the ICM2 motor.
 - PIN 10 - Ref. V - ICM2 reference voltage.
 - PIN 11 - Heat Tap - Heating blower speed programming.
 - PIN 12 - C - 24 VAC common.
 - PIN 13 - cfm - Motor speed diagnostic signal.

VOLTAGES INTO VSP2-1

Voltage across J73 pins 13 to 1 and 6 to 1 is 24VAC as shown here. Refer to unit wiring diagram.

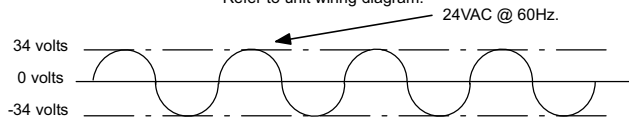

Voltage across J73 pins 4 to 1 is approximately 15-20VDC (straight voltage) if CCB is used. If Harmony is used a voltage of 0-25VDC should be present. If CCB or Harmony is not used, pin 4 to 1 voltage is 21VAC.

VOLTAGES FROM VSP2-1 TO ELECTRONICALLY CONTROLLED BLOWER MOTOR

Voltage across J46 pins 6 to 3 and 1 to 3 is half-rectified AC as shown here. Refer to unit wiring diagram.

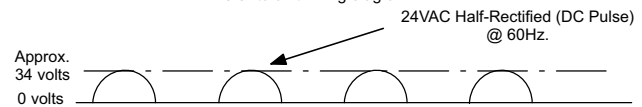

Voltage across J46 pins 8 and 9 to 3, is approximately 15-20VDC if CCB is used. If CCB or Harmony is not used, pins 8 and 9 to 3 voltage is approximately 21VAC. If Harmony is used a voltage of 0-25VDC should be present.

FIGURE 16

NOTE-On Harmony II zoning applications in the heating mode, the highest speed obtainable is the same as the highest cooling speed selection. Also, the heating speed (heat jumper position) is only used when the primary limit has been tripped. In non-zoning applications, refer to the section on the VSP2-1 control.

Jumper Settings

SEE BLOWER PERFORMANCE TABLES AT FRONT OF MANUAL FOR ANY REFERENCE TO CFM.

! IMPORTANT

Before changing jumper setting, make sure the motor has completely stopped. Any jumper setting change will not take place while the motor is running.

To change jumper positions, gently pull the jumper off the pins and place it on the desired set of pins. The following section outlines the different jumper selections available and conditions associated with each one. Refer to figure 15 for identification.

After the CFM for each application has been determined, the jumper settings must be adjusted to reflect those given in the tables in the blower performance section. Using the tables, determine which row of CFM volumes most closely matches the desired CFM. Once a specific row has been chosen (NORMAL or -), CFM volumes from other rows cannot be used. Below are the descriptions of each of the jumper selections.

Refer to table 5 for factory settings. Refer to the blower performance tables for the approximate air volume for each setting.

**TABLE 5
VSP2-1 FACTORY SETTINGS**

MODEL	HIGH	LOW	ADJUST	HEAT
GHR32V-75-1, -2, -3 units	4	3	NORM	2
GHR32V-100-1, -2, -3 units	4	2	NORM	1

a-“ADJUST”

The **ADJUST** pins allow the motor to run at normal speed or approximately 15% lower than normal speed. The blower performance tables give two rows (NORMAL and -) with their respective CFM volumes. The + adjustment setting is

not operable. Notice in the GHR32V5-100 table, that the normal adjustment setting for heat speed position #3 is 2150 CFM (1015L/s). After the adjustment setting has been determined, chose the remaining speed jumper settings from those offered in the table.

The TEST pin is available to bypass the VSP2-1 control and run the motor at approximately 70% to test that the motor is operational. This is beneficial primarily in troubleshooting. G must be energized for motor to run.

b-“HEATING BLOWER”

For GHRV32 units, place the **HEATING BLOWER** jumper across the second and third pins (position #2).

When W1 is energized, the **LOW** jumper selections are activated. The **HEAT** jumper selections are activated when W2 is energized.

NOTE-In Harmony II zoning applications, HEATING BLOWER jumper must be in position #2.

c-“HEAT”

The **HEAT** jumper is used to set the blower speed to obtain the required CFM as outlined in HEAT SPEED in the blower performance tables.

The **HEAT** jumper selections are activated with a call for second-stage heating (W2).

d-“HIGH”

The **HIGH** jumper is used to determine the CFM during cooling speed. These jumper selections are activated when G and DS terminals are energized.

e-“LOW”

The **LOW** jumper is used to determine CFM during low speed cooling. These jumper selections are activated when G is energized. The **LOW** jumper may also be used for low speed heating. See the “HEAT” section for details.

f-FAN “OFF”

Fan “OFF” timings (time that the blower operates after the heat demand has been satisfied) are determined by the arrangement of a jumper on the VSP2-1 board. See figure 17. To adjust fan “OFF” timings, gently disconnect the jumper and reposition it across pins corresponding with the new timing. Fan “OFF” time is adjustable from 90 to 330 seconds. The control has a non-adjustable, factory preset “on” fan timing (45 seconds).

WARNING - MAKE SURE TO DISCONNECT POWER BEFORE CHANGING FAN “OFF” TIMINGS.

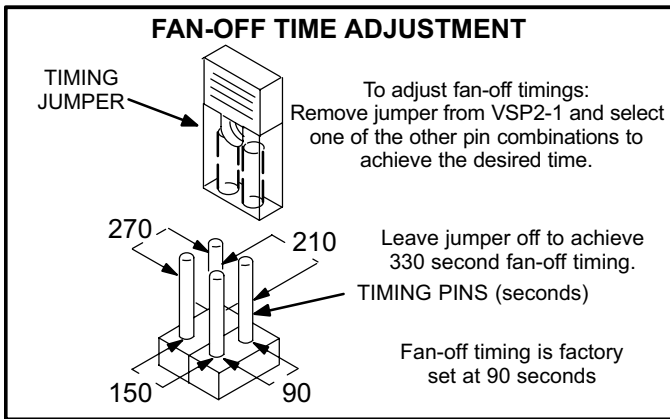

FIGURE 17

NOTE—If fan “OFF” time is too low, residual heat in heat exchanger may cause primary limit S10 to trip resulting in frequent cycling of blower. If this occurs, adjust blower to longer time setting.

Table 6 outlines the operation of the variable speed motor in relation to specific modes of operation. Some information has been repeated from the previous section to provide an example. Refer to each diagnostic LED or jumper settings section for more information.

TABLE 6
VSP2-1 GHR32-1 through -3 units OPERATION

HEATING MODE		COOLING MODE	
UNITS WITH SINGLE-STAGE HEATING	UNITS WITH TWO-STAGE HEATING	UNITS WITH SINGLE-SPEED COMPRESSOR	UNITS WITH TWO-SPEED COMPRESSOR
<p>NON-ZONED APPLICATIONS</p> <p>Using a single-stage thermostat with “one-stage” heating, the HEAT LED-DS2 is lit when the thermostat calls for heat. The ON/OFF LED-DS3 is lit after 110 seconds (65 seconds pre-purge and 45 seconds fan “ON” time) from the time a call for heat is made. This indicates the blower is operating in heating speed.</p> <p>Using a single-stage thermostat with “W2 TIMED,” and W1 calling, the ON/OFF LED-DS3 is lit to indicate the blower is operating on low speed.</p> <p>When the HEAT LED-DS2 is lit, the blower is operating in heating speed, and second-stage (W2) heating is calling.</p>	<p>NON-ZONED APPLICATIONS</p> <p>Using a two-stage thermostat with first-stage (W1) calling, the ON/OFF LED-DS3 is lit to indicate the blower is operating in low speed.</p> <p>When the ON/OFF LED-DS3 and HEAT LED-DS2 are lit, the blower is operating in heating speed and second-stage (W2) heating is calling.</p> <p>HEAT LED-DS2 is lit with a call for heat from the thermostat. ON/OFF LED-DS3 is lit after 110 seconds from the time a call for heat is made.</p>	<p>NON-ZONED APPLICATIONS</p> <p>The terminals DS and Y must be jumpered together. With a call for cooling, terminals G, Y and DS on the unit control board are energized from the thermostat. HI/LOW LED-DS1 and ON/OFF LED-DS3 are lit to indicate the blower is operating on high speed.</p> <p><i>NOTE—Y and DS are factory jumpered for single-stage cooling, non-zoned applications.</i></p> <p><i>NOTE—For low speed during single-stage cooling remove jumper from Y to DS.</i></p>	<p>NON-ZONED APPLICATIONS</p> <p>The ON/OFF LED-DS3 is lit to indicate the blower is operating in first stage cooling. This LED is energized on when a 24VAC thermostat demand is supplied to the control (terminal “G” on the control board terminal strip).</p> <p>In second stage, the ON/OFF LED-DS3 and HI/LOW LED-DS1 are lit to indicate the blower is operating on high speed (24VAC is supplied to the unit terminal strip Y2 from Y2 on the thermostat).</p> <p><i>NOTE— Jumper must be moved from Y1 to Y2 In two-speed, non-zoned applications.</i></p>
<p>HARMONY ZONED APPLICATIONS</p> <p>The blower speed is controlled by the PWM (pulse width modulation) signal sent from the control center of the zoning system to the terminal strip’s DS terminal. HI/LOW LED-DS1 and ON/OFF LED-DS3 are lit to indicate the blower is operating.</p> <p><i>NOTE—In Harmony II zoning applications, HTG. BLOWER jumper must be in position #2.</i></p>	<p>HARMONY ZONED APPLICATIONS</p> <p>The blower speed is controlled by the PWM (pulse width modulation) signal sent from the control center of the zoning system to the terminal strip’s DS terminal. HI/LOW LED-DS1 and ON/OFF LED-DS3 are lit to indicate the blower is operating.</p> <p><i>NOTE—In Harmony II zoning applications, HTG. BLOWER jumper must be in position #2.</i></p>	<p>HARMONY ZONED APPLICATIONS</p> <p>The blower speed is controlled by the PWM (pulse width modulation) signal sent from the control center of the zoning system to the terminal strip’s DS terminal. HI/LOW LED-DS1 and ON/OFF LED-DS3 are lit to indicate the blower is operating.</p>	<p>HARMONY ZONED APPLICATIONS</p> <p>The blower speed is controlled by the PWM (pulse width modulation) signal sent from the control center of the zoning system to the terminal strip’s DS terminal. HI/LOW LED-DS1 and ON/OFF LED-DS3 are lit to indicate the blower is operating.</p>

NOTE: For zone applications with Harmony, remove the wire from the pin #3 of the J73 terminal on the VSP control board, insulate the end, and secure it to prevent from shorting.

7.VSP3-1 Blower Control Board (A24) GHR32V-4 Units

GHR32V-4 units are equipped with a variable speed motor that is capable of maintaining a specified CFM throughout the external static range. The unit uses the VSP3-1 variable speed control board, located in the blower compartment, which controls the blower speed and provides diagnostic LEDs. The control has both a non-adjustable, factory preset "ON" fan timing delay and an adjustable "OFF" fan timing delay (see figure 17).

The VSP3-1 also senses limit trip condition and turns on the blower. The GHR32V limit switch is located in the middle of the vestibule wall. When excess heat is sensed in the heat exchanger, the limit switch will open and interrupt the current to the gas valve, while at the same time the VSP3-1 energizes the blower on heating speed. The limit automatically resets when the unit temperature returns to normal and the blower is de-energized.

Diagnostic LEDs located on the VSP3-1 control board are provided to aid in identifying the unit's mode of operation. Certain scenarios will arise depending on the jumper positions. Refer to figure 18 for identification.

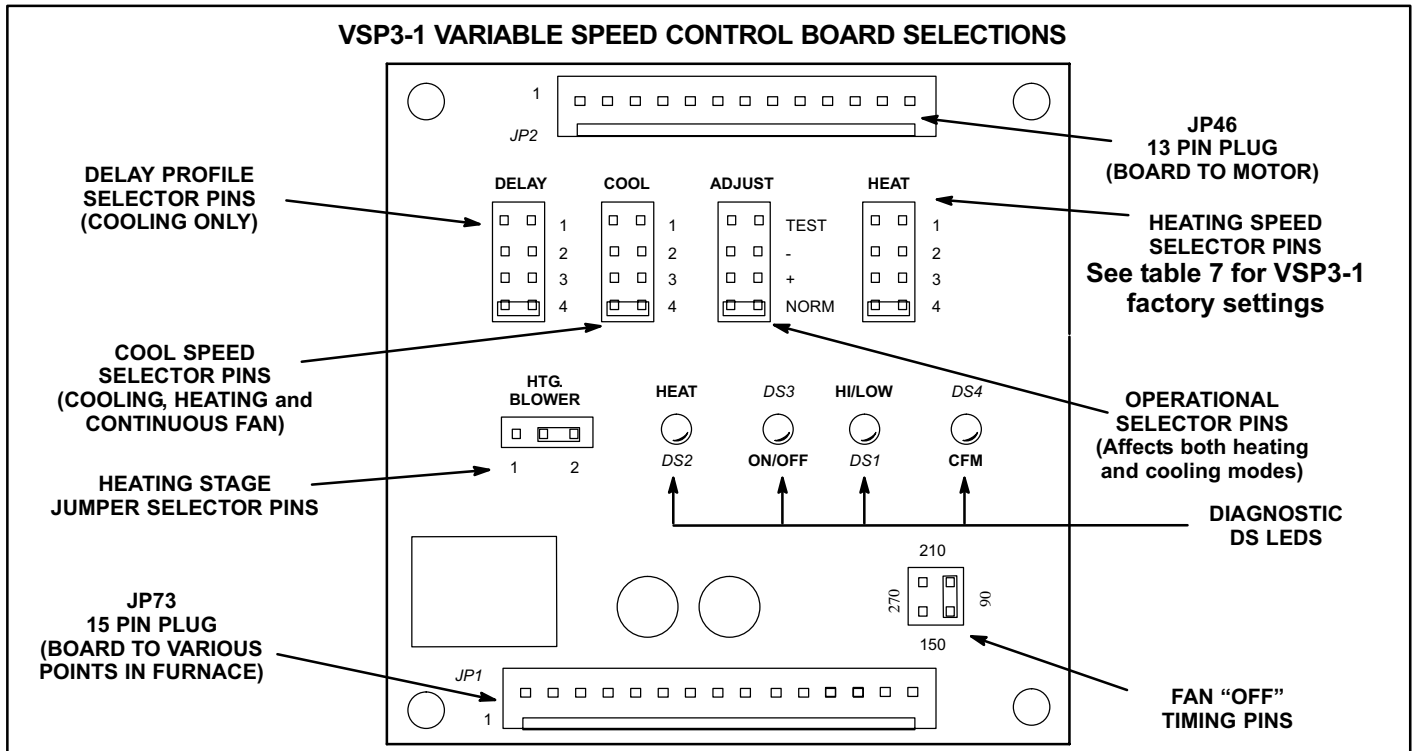
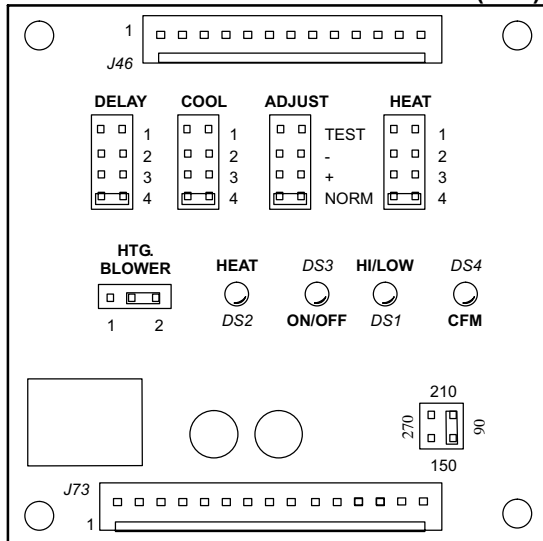

FIGURE 18

VSP3-1 BLOWER CONTROL BOARD (A24)



- J73**
- PIN 1 - C - 24 VAC common.
 - PIN 2 - G - Input signal from thermostat's fan signal.
 - PIN 3 - W2 - Input signal for second stage heat from the thermostat.
 - PIN 4 - DS - Input signal for the blower speed regulation.
 - PIN 5 - Limit - Input signal from the external limit.
 - PIN 6 - R - 24 VAC power to the thermostat.
 - PIN 7 - C - 24 VAC common.
 - PIN 8 - C - 24 VAC common.
 - PIN 9 - C1 - Input signal from the fan limit control.
 - PIN 10 - CO - Output signal to the burner control.
 - PIN 11 - HT - Input signal from the fan limit control.
 - PIN 12 - ACC - 24 VAC accessory output.
 - PIN 13 - 24V - Input 24 VAC power for the VSP2-1.
 - PIN 14 - 24V - Input 24 VAC power for the VSP2-1.
 - PIN 15 - V - Input signal from the gas line.
- J46**
- PIN 1 - Not Used.
 - PIN 2 - C - 24 VAC common.
 - PIN 3 - C - 24 VAC common.
 - PIN 4 - Delay Tap - Delay profile programming input.
 - PIN 5 - Cooling blower speed programming input.
 - PIN 6 - On / Off - On / off output signal to the ICM2 motor.
 - PIN 7 - Adjust Tap - ICM2 mode selection.
 - PIN 8 - NOT USED
 - PIN 9 - Hi / Low - Speed regulate input signal to the ICM2 motor with CCB1 and HARMONY only
 - PIN 10 - Ref. V - ICM2 reference voltage.
 - PIN 11 - Heat Tap - Heating blower speed programming.
 - PIN 12 - C - 24 VAC common.
 - PIN 13 - cfm - Motor speed diagnostic signal.

VOLTAGES INTO VSP3-1

Voltage across J73 pins 13 to 1 and 6 to 1 is 24VAC as shown here. Refer to unit wiring diagram.

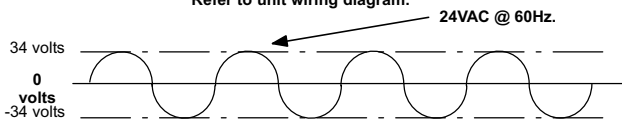

Voltage across J73 pins 4 to 1 is approximately 15-20VDC (straight voltage) if CCB is used. If Harmony is used a voltage of 0-25VDC should be present. If CCB or Harmony is not used, pin 4 to 1 voltage is 21VAC.

VOLTAGES FROM VSP3-1 TO ELECTRONICALLY CONTROLLED BLOWER MOTOR

Voltage across J46 pins 6 to 3 and 1 to 3 is half-rectified AC as shown here. Refer to unit wiring diagram.

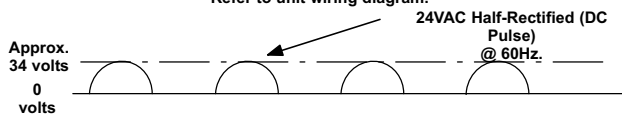

Voltage across J46 pin 9 to 3 is approximately 15-20VDC if CCB is used. If CCB or Harmony is not used, pin 9 to 3 voltage is approximately 21VAC. If Harmony is used a voltage of 0-25VDC should be present.

FIGURE 19

⚠ IMPORTANT

24 VAC half wave rectified (DC pulse), when measured with a meter, may appear as a lower or higher voltage depending on the make of the meter. Rather than attempting to measure the output voltage of A24, see GHR32V BLOWER & VSP3 BLOWER CONTROL BOARD TROUBLESHOOTING FLOW CHART in the TROUBLESHOOTING section of this manual.

Diagnostic LED Lights

DS3 ON/OFF

ON/OFF-DS3 indicates there is a demand for the blower motor to run. When the **ON/OFF LED-DS3** is lit, a demand is being sent to the motor. In heating mode only, there is a 45-second fan "ON" delay in energizing **ON/OFF LED-DS3**. Light will not go off until adjustable fan "OFF" delay has expired.

If **ON/OFF LED-DS3** is on and both **HIGH/LOW LED-DS1** & **HEAT LED-DS2** are off, the motor will operate in low speed (heating).

DS2 HEAT

If **HEAT LED-DS2** is on, the blower is running in second-stage heat speed according to the "HEAT" jumper setting. In heating mode only, there is a 45 second delay in energizing **HEAT LED-DS2**. Light will not go off until adjustable fan "OFF" delay has expired.

DS1 HI/LOW

HIGH/LOW LED-DS1 indicates the blower is operating in the cooling mode.

DS4 CFM

CFM LED-DS4 indicates the CFM the blower is providing, according to the jumper settings.

Jumper Settings

SEE BLOWER PERFORMANCE TABLES AT FRONT OF MANUAL FOR ANY REFERENCE TO CFM.

⚠ IMPORTANT

Before changing jumper setting, make sure the motor has completely stopped. Any jumper setting change will not take place while the motor is running.

To change jumper positions, gently pull the jumper off the pins and place it on the desired set of pins. The following section outlines the different jumper selections available and conditions associated with each one. Refer to figure 18 for identification.

After the CFM for each application has been determined, the jumper settings must be adjusted to reflect those given in the blower performance tables. Using the tables, determine which row of CFM volumes most closely matches the desired CFM. Once a specific row has been chosen (NORMAL or -), CFM volumes from other rows cannot be used. Below are the descriptions of each of the jumper selections.

Refer to table 7 for factory settings.

TABLE 7
VSP FACTORY SETTINGS FOR GHR32V-4 UNITS

MODEL	DELAY	COOL	ADJUST	HEAT
GHR32V3-75	4	4	NORM	3
GHR32V5-100	4	4	NORM	2

NOTE - In Harmony II zoning applications in the heating mode, the highest cooling speed selected is the highest blower speed obtainable. Also, the fan-only speed is used when the primary limit has been tripped. In non-zoning applications, refer to the section on the VSP3-1 control.

ADJUST

The **ADJUST** pins allow the motor to run at normal speed or approximately 15% lower than normal speed. The blower performance tables two rows (NORMAL and -) with their respective CFM volumes. The + adjustment setting is not operable. Notice that the normal adjustment setting for heat speed position #3 is 2150 CFM (1015 L/s). After the adjustment setting has been determined, choose the remainder speed jumper settings from those in the table.

The **TEST** pin is available to bypass the VSP3-1 control and run the motor at approximately 70% to test that the motor is operational. This is beneficial primarily in troubleshooting. G must be energized for motor to run.

HTG. BLOWER

For GHR32V-4 units only, place the **HTG. BLOWER** jumper across the second and third pins (position #2).

NOTE - In Harmony II zoning applications, HTG. BLOWER jumper must be in position #2.

HEAT

The **HEAT** jumper is used to set the blower speed to obtain the required CFM as outlined in HEAT SPEED section of the blower performance tables. The **HEAT** jumper selections are activated with a call for first-stage heating (W1) and second-stage heating (W2).

DELAY

The **DELAY** jumper is used to set the specific motor fan mode of operation during cooling. Depending on the application, one of four fan options may be chosen by moving the jumper to the appropriate set of pins.

Options 1, 2, 3, or 4 will have an increased dehumidification effect on the system. Option 1 will have the least effect and option 4 will have the greatest effect.

#1 PIN JUMPERED

- A - Motor runs at 100% until demand is satisfied.
- B - Once demand is met, motor ramps down to off.

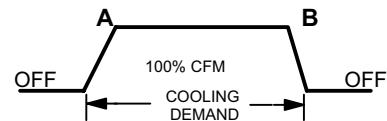

#2 PIN JUMPERED

- A - Motor runs at 82% for approximately 7-1/2 minutes.
- B - If demand has not been satisfied after 7-1/2 minutes, the motor runs at 100% until demand is satisfied.
- C - Once demand is met, motor ramps down to off.

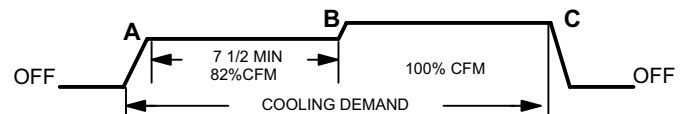

#3 PIN JUMPERED

- A - Motor runs at 50% for 1/2 minute.
- B - Motor then runs at 82% for approximately 7-1/2 minutes.
- C - If demand has not been satisfied after 7-1/2 minutes, motor runs at 100% until demand is satisfied.
- D - Once demand is met, motor ramps down to off.

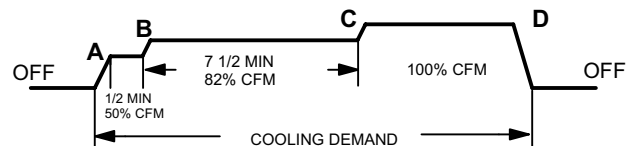

#4 PIN JUMPERED

- A** - Motor runs at 50% for 1/2 minute.
- B** - Motor then runs at 82% for approximately 7-1/2 minutes.
- C** - If demand has not been satisfied after 7-1/2 minutes, motor runs at 100% until demand is satisfied.
- D** - Once demand is met, motor runs at 50% for 1/2 minute.
- E** - Motor ramps down to off.

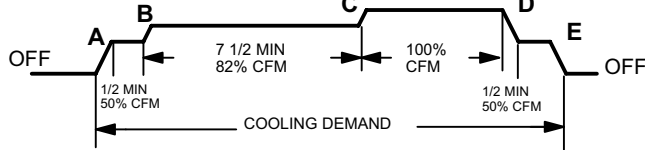

COOL

The cool jumper is used to set the blower speed to obtain the required CFM as outlined in the blower performance tables.

VSP Operation

Table 8 outlines the operation of the variable speed motor in relation to specific modes of operation. See table 9 for GHR32V with CCB1 and a two speed outdoor unit. Some information has been repeated from the previous section to provide an example. Refer to each diagnostic LED or jumper settings section for more information.

TABLE 8
GHR32V-4 Units with VSP3-1

Heating Mode		Cooling Mode	
Units With Single-Stage Heating	Units With Two-Stage Heating	Units With Single-speed Compressor	Units With Two-speed Compressor
<p>Non-Zoned Applications</p> <p>Using a single-stage thermostat with "one-stage" heating, the HEAT LED-DS2 is lit when the thermostat calls for heat. The ON/OFF LED-DS3 is lit after 110 seconds (65 seconds prepurge and 45 seconds fan "ON" time) from the time a call for heat is made. This indicates the blower is operating in high speed heat.</p> <p>Using a single-stage thermostat with "W2 TIMED" and W1 calling, the ON/OFF LED-DS3 is lit to indicate the blower is operating on low speed heat.</p> <p>When HEAT LED-DS2 is lit, the blower is operating in high speed heat and second-stage (W2) is calling.</p>	<p>Non-Zoned Applications</p> <p>Using a two-stage thermostat with first-stage (W1) calling, the ON/OFF LED-DS3 is lit to indicate the blower is operating in low speed heat.</p> <p>When the ON/OFF LED-DS3 and HEAT LED-DS2 are lit, the blower is operating in high speed heat and second-stage (W2) is calling.</p> <p>HEAT LED-DS2 is lit with a call for heat from the thermostat. ON/OFF LED-DS3 is after 110 seconds from the time a call for heat is made.</p>	<p>Non-Zoned Applications</p> <p>Y1-DS and Y1-Y2 must be jumpered together. With a call for cooling, G, Y1, Y2 and DS on the unit control board are energized from the thermostat. HI/LOW LED-DS1 and ON/OFF LED-DS3 are lit to indicate a call for cooling.</p> <p><i>Note - Y1 to DS and Y1 to Y2 are factory jumpered for single-stage cooling, non-zoned applications.</i></p>	<p>Non-Zoned Applications</p> <p>Y1-DS must be jumpered together. With a call for single-stage cooling, G, Y1, and DS on the unit control board are energized from the Thermostat. With a call for second-stage cooling, G, Y1, Y2, and DS on the unit control board are energized from the thermostat. In both cases, HI/LOW LED-DS1 and ON/OFF LED-DS3 are lit to indicate a call for cooling.</p> <p><i>Note - Jumper Y1-Y2 must be removed for units with two-speed compressor.</i></p>
<p>Harmony Zoned Applications</p> <p>The blower speed is controlled by the PWM (pulse width modulation) signal sent from the control center of the zoning system to the terminal strip's DS terminal. HI/LOW LED-DS1 and ON/OFF LED-DS3 are lit to indicate the blower is operating.</p> <p><i>Note - In Harmony II zoning applications, HTG BLOWER jumper must be in position #2.</i></p>	<p>Harmony Zoned Application</p> <p>The blower speed is controlled by the PWM (pulse width modulation) signal sent from the control center of the zoning system to the terminal strip's DS terminal. HI/LOW LED-DS1 and ON/OFF LED-DS3 are lit to indicate the blower is operating.</p> <p><i>Note - In Harmony II zoning applications, HTG BLOWER jumper must be in position #2.</i></p>	<p>Harmony Zoned Application</p> <p>The blower speed is controlled by the PWM (pulse width modulation) signal sent from the control center of the zoning system to the terminal strip's DS terminal. HI/LOW LED-DS1 and ON/OFF LED-DS3 are lit to indicate the blower is operating.</p>	<p>Harmony Zoned Application</p> <p>The blower speed is controlled by the PWM (pulse width modulation) signal sent from the control center of the zoning system to the terminal strip's DS terminal. HI/LOW LED-DS1 and ON/OFF LED-DS3 are lit to indicate the blower is operating.</p>

NOTE - For zone applications with Harmony, remove the wire from pin #2 and pin #13 of the J49 terminal at the motor and the wire from pin #3 of the J73 terminal on the VSP control board, insulate the ends and secure to prevent shorting.

**TABLE 9
GHR32V-4 UNITS WITH CCB1 & TWO-SPEED OUTDOOR UNIT OPERATING SEQUENCE**

Operating Sequence		System Demand		System Response		
System Condition	Step	Thermostat Demand	*Relative Humidity (EfficiencyPlus Lights)	***Compressor Speed	Blower CFM (COOL)	Comments
Normal operation	1	Y1	Acceptable (None)	Low	55% of HIGH COOL	Compressor demand and indoor blower speed follow thermostat demand
	2	Y2	Acceptable (None)	High	HIGH COOL	
Call for humidity removal during 1st stage thermostat demand	1	Y1	Acceptable (None)	Low	55% of HIGH COOL	Dehumidification mode begins with next thermostat demand, after initial thermostat demand is satisfied.
	2	Y1	Change to slightly over setpoint (1)	Low	55% of HIGH COOL	
	3	Demand satisfied	Slightly over setpoint (1)	Off	Off	
	4	Y1	Slightly over setpoint (1)	High	**77%/74% of HIGH COOL	
Significant increase in humidity during thermostat demand.	1	Y1	Acceptable (None)	Low	55% of HIGH COOL	If humidity increases significantly over setpoint, or if slide switch is moved significantly, unit will immediately go into dehumidification mode (in presence of thermostat demand).
	2	Y1	Change to significantly over setpoint (2 or more)	High	**77%/74% of HIGH COOL	
Humidity demand satisfied during thermostat demand.	1	Y1	Over Setpoint	High	**77%/74% of HIGH COOL	When humidity demand is satisfied, blower immediately shifts to the HIGH COOL CFM in order to hasten the end of the cycle. Unit can only shift out of high speed compressor operation at beginning of next cycle.
	2	Y1	Change to Acceptable (None)	High	HIGH COOL	
	3	None	Acceptable (None)	Off	Off	
	4	Y1	Acceptable (None)	Low	55% of HIGH COOL	
Call for humidity removal during 2nd stage thermostat demand	1	Y2	Acceptable (None)	High	HIGH COOL	Blower immediately changes speed in response to thermostat demand.
	2	Y2	Change to slightly over setpoint (1)	High	**77%/74% of HIGH COOL	
	3	Y2	Acceptable (None)	High	HIGH COOL	
*Call for 1st stage cooling after call for humidity removal.	1	None	Slightly over setpoint (1)	Off	Off	Dehumidification mode (high speed compressor) begins with next thermostat demand after initial demand is satisfied.
	2	Y1	Slightly over setpoint (1)	Low	55% of HIGH COOL	
Call for 2nd stage cooling after call for humidity removal	1	None	Slightly over setpoint (1)	Off	Off	Reduced blower speed (dehumidification speed) begins immediately with thermostat demand
	2	Y2	Slightly over setpoint (1)	High	**77%/74% of HIGH COOL	
Call for cooling after significant increase in humidity	1	None	Significantly over setpoint (2 or more)	Off	Off	If humidity increases significantly over setpoint, or if slide switch is moved, unit immediately goes into dehumidification mode (in presence of thermostat demand).
	2	Y1 or Y2	Significantly over setpoint (2 or more)	High	**77%/74% of HIGH COOL	
Humidity demand satisfied between thermostat demands (unit off cycle).	1	None	Over setpoint (1 or more)	Off	Off	While unit is not operating (no thermostat demand), slide switch is moved down and back up. Blower and compressor operate at high speed until next thermostat demand.
	2	Y1 or Y2	Change to acceptable (None)	High	HIGH COOL	

Note - When changing unit mode of operation from cooling to heating, indicating lights that are on will stay on until the first thermostat heating demand.

**IMPORTANT - If power to unit is turned on with CCB1 calling for humidity removal, outdoor unit may be locked into high speed indefinitely. To reset, move humidity slide switch all the way down then back up to desired setpoint (with unit running)*

*** Reduced blower speed is 77% of COOL for the V3 units; 74% of COOL for V5.*

****If the two-speed control on a two-speed outdoor unit is set for LATCH 2 (15 minutes) or LATCH 3 (30 minutes), the compressor will latch into high speed after a Y1 demand has occurred for that period of time.*

8. Two Stage Integrated Control (A92) GHR32Q-5 Units

DANGER

Shock hazard.

Disconnect power before servicing. Control is not field repairable. If control is inoperable, simply replace entire control.

Can cause injury or death. Unsafe operation will result if repair is attempted.

All GHR32Q units are equipped with the Lennox two-stage integrated SureLight control board. The system consists of a ignition control board (figure 20 with control terminal designations in tables 12, 13 and 14) and ignitor (figure 8). The board and ignitor work in combination to ensure furnace ignition and ignitor durability. The board controls all major furnace operations. The board features two LED lights, DS1 and DS2 for troubleshooting. The board also has two accessory terminals rated at (1) one amp each. See table 15 for troubleshooting diagnostic codes.

Electronic Ignition

At the beginning of each heat cycle, SureLight control monitors the first stage and second stage combustion air inducer prove switch. The control will not begin the heating cycle if the first stage prove switch is closed (by-passed). Likewise the control will not begin the second stage heating cycle if the second stage prove switch is closed and will allow first stage heat only. However if the second stage prove switch closes during the first stage pre-purge, the control will still respond to second stage heat. Once the first stage prove switch is determined to be open, the combustion air inducer is energized on low (first stage) heat speed. When the differential in the prove switch is great enough, the prove switch closes and a 15-second pre-purge begins. If the switch is not proven within 2-1/2 minutes, the control goes into Watchguard-Pressure Switch mode for a 5-minute re-set period.

After the 15-second pre-purge period, the SureLight ignitor warms up for 20 seconds after which the gas valve opens for a 4-second trial for ignition. The ignitor energizes during the trial until flame is sensed. If ignition is not proved during the 4-second period, the control will try four more times with an inter purge and warm-up time between trials of 35 seconds. After a total of five trials for ignition (including the initial trial), the control goes into Watchguard-Flame Failure mode. After a 60-minute reset period, the control will begin the ignition sequence again.

The SureLight control board has an added feature that prolongs the life of the ignitor. After a successful ignition, the SureLight control utilizes less power to energize the ignitor on successive calls for heat. The control continues to ramp down the voltage to the ignitor until it finds the lowest amount of power that will provide a successful ignition. This amount of power is used for 255 cycles. On the 256th call for heat, the control will again ramp down until the lowest power is determined and the cycle begins again.

Two Stage Operation / Thermostat Selection Jumper

The control can be utilized in two modes: SINGLE-STAGE thermostat or TWO-STAGE thermostat. The thermostat selection jumper E20, located just below dip switches 1 through 4 (figure 20), must be positioned for the particular application. The jumper is factory set on "TWO" for use with a two-stage thermostat with two stage heat. Re-position jumper to "SINGLE" for use with a single stage thermostat with two stage heat.

While in the single-stage thermostat mode (*single* jumper setting), the burners will always fire on first-stage heat. The combustion air inducer will operate on low speed and indoor blower will operate on low heat speed. After a field selectable 10 or 15 minute delay (dip switch 3), the unit will switch to second stage heat. While in the two-stage thermostat mode (*two* jumper setting) the burners will fire on first-stage heat. The combustion air inducer will operate on low speed and indoor blower will operate on low heat speed. The unit will switch to second-stage heat on call from the indoor thermostat. If there is a simultaneous call for W1 and W2 (first and second stage heat) the unit will fire on first stage heat and will switch to second stage heat after 30 seconds of operation. See Sequence of Operation flow charts in the back of this manual for more detail.

Dip Switch Settings

Dip Switches 1 and 2 - Heating Fan off Delay - The fan on time of 45 seconds is not adjustable. Fan off time (time that the blower operates after the heat demand has been satisfied) can be adjusted by flipping the dip switches 1 and 2 located on the SureLight integrated control. The unit is shipped with a factory fan off setting of 90 seconds. Fan off time will affect comfort and is adjustable to satisfy individual applications. For customized comfort, monitor the supply air temperature once the heat demand is satisfied. Note the supply air temperature at the instant the blower is de-energized. Adjust the fan-off delay to achieve a supply air temperature between 90° - 110° at the instant the blower is de-energized. (Longer delay times allow for lower air temperature, shorter delay times allow for higher air temperature). See table 10 for dip switch settings.

TABLE 10

Heating Fan Off Delay

Delay (Seconds)	Switch 1	Switch 2
60	Off	Off
90	Off	On
120	On	Off
180	On	On

Switch 3 - Second Stage Delay (Used with Single-Stage Thermostat Only) --

This switch is used to determine the second stage on delay when a single-stage thermostat is being used. The switch is factory-set in the ON position, which provides a 10-minute delay before second-stage heat is initiated. If the switch is toggled to the OFF position,

it will provide a 15-minute delay before second-stage heat is initiated. This switch is only activated when the thermostat selector jumper is positioned for SINGLE-stage thermostat use.

Switch 4 - Cooling Fan off Delay - The fan on delay time of 2 seconds is not adjustable. Fan off time (time that the blower operates after the cool demand has been satisfied) can be adjusted by flipping dip switch 4. The unit is shipped with a factory fan off setting of 45 seconds. Fan off time will affect comfort and is adjustable to satisfy individual applications. See table 11 for cool fan off time settings.

TABLE 11
Cooling Fan Off Delay

Delay (Seconds)	Switch 4
2	Off
45	On

Diagnostic LED's (DS1 and DS2)

Two diagnostic LED'S are located on the two-stage integrated control board. See figure 20. These light flashes correspond with the codes detailed in table 15.

Factory Installed Jumper Y1 to Y2

A factory-installed jumper from Y1 to Y2 terminals on the integrated control board terminal strip must be removed for two-stage cooling.

TABLE 12

Integrated Control Board Terminals	
120VAC Neutral	
LINE	Line
XFMR	Transformer
EAC	Electronic Air Cleaner
CIRC	Indoor Blower
HUM	Humidifier
120VAC Line	
HUM	Humidifier
XMFR	Transformer
LINE	Line
PARK	For Unused Leads
COOL	Cooling Speed
EAC	Electronic Air Cleaner
HI HEAT	High Heat Speed
LO HEAT	Low Heat, Low Cool and Continuous Fan Speed

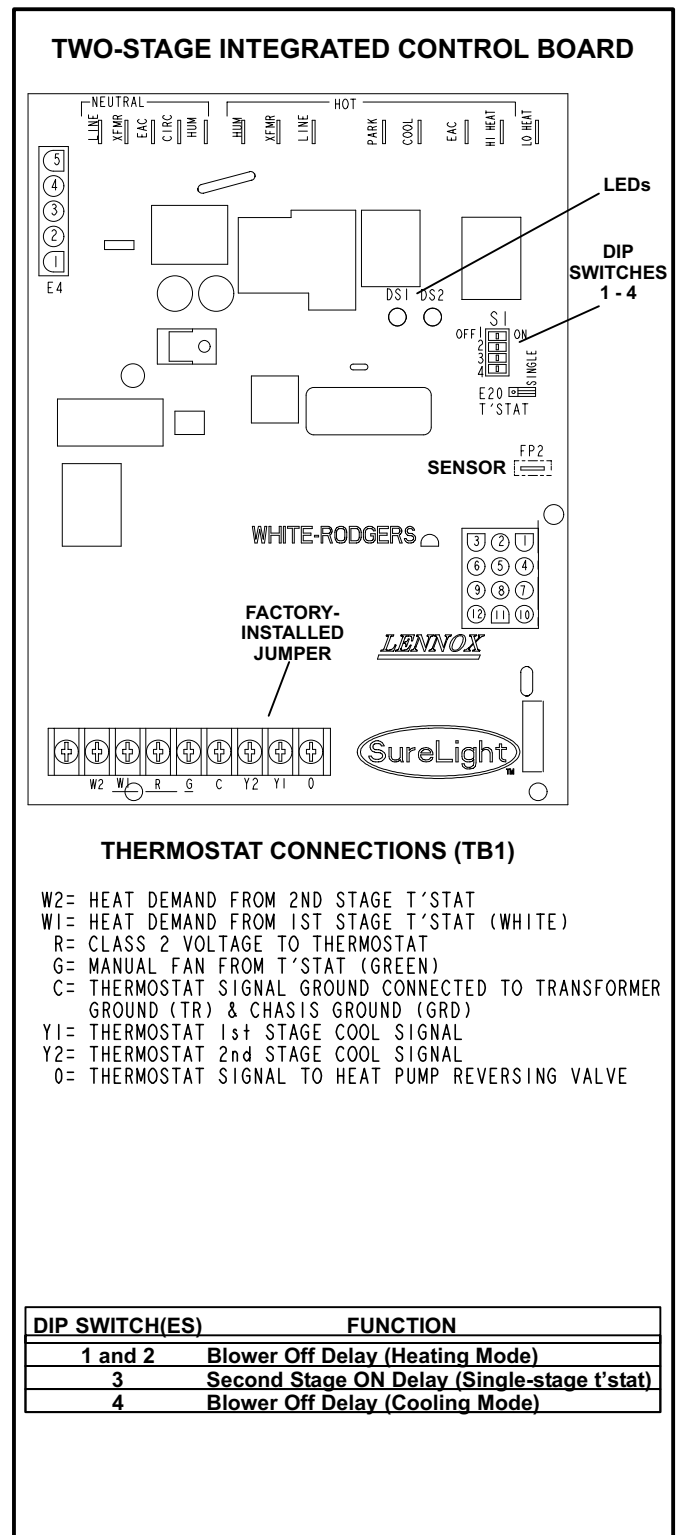

THERMOSTAT CONNECTIONS (TB1)

- W2= HEAT DEMAND FROM 2ND STAGE T' STAT
- W1= HEAT DEMAND FROM 1ST STAGE T' STAT (WHITE)
- R= CLASS 2 VOLTAGE TO THERMOSTAT
- G= MANUAL FAN FROM T' STAT (GREEN)
- C= THERMOSTAT SIGNAL GROUND CONNECTED TO TRANSFORMER GROUND (TR) & CHASSIS GROUND (GRD)
- Y1= THERMOSTAT 1st STAGE COOL SIGNAL
- Y2= THERMOSTAT 2nd STAGE COOL SIGNAL
- O= THERMOSTAT SIGNAL TO HEAT PUMP REVERSING VALVE

DIP SWITCH(ES)	FUNCTION
1 and 2	Blower Off Delay (Heating Mode)
3	Second Stage ON Delay (Single-stage t'stat)
4	Blower Off Delay (Cooling Mode)

FIGURE 20

TABLE 13

Integrated Control Board 5 Pin Terminal	
PIN #	Function
1	Ignitor
2	Combustion Air Inducer High Speed
3	Combustion Air Inducer Low Speed
4	Combustion Air Inducer Neutral
5	Ignitor Neutral

TABLE 14

Integrated Control Board 12Pin Terminal	
PIN #	Function
1	Gas Valve 2nd Stage (High Fire)
2	Second Stage Prove Switch
3	Not Used
4	Ground
5	24V Hot
6	Primary Limit In
7	Gas Valve 1st stage (Low Fire)
8	Gas Valve Common
9	24V Neutral
10	Ground
11	Primary Limit Out
12	1st Stage Prove Switch

TABLE 15

DIAGNOSTIC CODES		
Diagnostic LEDs are labeled DS1 and DS2. See figure 20 for location of diagnostic LEDs.		
DS1	DS2	DESCRIPTION
SIMULTANEOUS SLOW FLASH	SIMULTANEOUS SLOW FLASH	Power on - Normal operation. Also signaled during cooling and continuous fan.
SIMULTANEOUS FAST FLASH	SIMULTANEOUS FAST FLASH	Normal operation - signaled when heating demand initiated at thermostat.
SLOW FLASH	ON	Primary, secondary or rollout limit switch open. Limits must close within 3 minutes or unit goes into 1 hour Watchguard.
OFF	SLOW FLASH	Pressure switch open; OR: Blocked inlet/exhaust vent; OR: Pressure switch closed prior to activation of combustion air inducer.
OFF	FAST FLASH	Pressure switch open; OR: Blocked inlet/exhaust vent; OR: Pressure switch closed prior to activation of combustion air inducer.
ALTERNATING SLOW FLASH	ALTERNATING SLOW FLASH	Watchguard -- burners failed to ignite; OR limit open more than 3 minutes; OR lost flame sense 5 times in one heating cycle; OR pressure switch opened 5 times in one heating cycle.
SLOW FLASH	OFF	Flame sensed without gas valve energized.
ON ON OFF	ON OFF ON	Circuit board failure or control wired incorrectly. Check 24 and 115 volts to board.
FAST FLASH	SLOW FLASH	Main power polarity reversed. Switch line and neutral.
SLOW FLASH	FAST FLASH	Low flame signal. Measures below 0.23 microAmps. Replace flame sense rod.
ALTERNATING FAST FLASH	ALTERNATING FAST FLASH	The following conditions are sensed during the ignitor warm-up period only: 1) Improper main ground; 2) Broken ignitor; OR: Open ignitor circuit; 3) Line voltage below 75 volts. (If voltage lower than 75 volts prior to ignitor warm-up, control will signal waiting on call from thermostat, and will not respond.

NOTE - Slow flash rate equals 1 Hz (one flash per second). Fast flash rate equals 3 Hz (three flashes per second). Minimum flame sense current = 0.17-0.22 microAmps.

9. Two Stage Variable Speed Integrated Control (A92) GHR32V-5 Units

All GHR32V-5 units are equipped with the Lennox two-stage, variable speed integrated SureLight control board. The system consists of a ignition / blower control board (figure 21 with control terminal designations in tables 16 through 19) and ignitor (figure 8). The board and ignitor work in combination to ensure furnace ignition and ignitor durability. The SureLight integrated board controls all major furnace operations. The board features two LED lights, DS1 and DS2 for troubleshooting and four LED lights (DS3, DS6, DS7 and DS8) to show furnace status. The board also has two accessory terminals rated at (1) one amp each. See table 20 for status code and table 21 for troubleshooting diagnostic codes.

Electronic Ignition

At the beginning of each heating cycle, the SureLight control monitors the first stage and second stage combustion air inducer prove switch. The control will not begin the heating cycle if the first stage prove switch is closed (bypassed). Likewise the control will not begin the second stage heating cycle if the second stage prove switch is closed, and will allow first stage heat only. However if the second stage prove switch closes during the first stage pre-purge, the control WILL respond to second stage heat call. Once the first stage prove switch is determined to be open, the combustion air inducer is energized on low (first stage) heat speed. When the differential in the prove switch is great enough, the prove switch closes and a 15-second pre-purge begins. If the switch is not proven within 2-1/2 minutes, the control goes into Watchguard-Pressure Switch mode for a 5-minute re-set period.

After the 15-second pre-purge period, the SureLight ignitor warms up for 20 seconds after which the gas valve opens for a 4-second trial for ignition. The ignitor energizes during the trial until flame is sensed. If ignition is not proved during the 4-second period, the control will try four more times with an inter purge and warm-up time between trials of 35 seconds. After a total of five trials for ignition (including the initial trial), the control goes into Watchguard-Flame Failure mode. After a 60-minute reset period, the control will begin the ignition sequence again.

The SureLight control board has an added feature that prolongs the life of the ignitor. After a successful ignition, the SureLight control utilizes less power to energize the ignitor on successive calls for heat. The control continues to ramp down the voltage to the ignitor until it finds the lowest amount of power that will provide a successful ignition. This amount of power is used for 255 cycles. On the 256th call for heat, the control will again ramp down until the lowest power is determined and the cycle begins again.

Two Stage Operation / Thermostat Selection Jumper

The control can be utilized in two modes: SINGLE-STAGE thermostat or TWO-STAGE thermostat. The thermostat selection jumper E20, located just below dip switches 1 through 3 (figure 21), must be positioned for the particular application. The jumper is factory set on "TWO" for use with a two-stage thermostat with two stage heat. Re-position jumper to "SINGLE" for use with a single stage thermostat with two stage heat.

While in the single-stage thermostat mode (*single* jumper setting), the burners will always fire on first-stage heat. The combustion air inducer will operate on low speed and indoor blower will operate on low heat speed. After a field selectable 10 or 15 minute delay (dip switch 3), the unit will switch to second stage heat. While in the two-stage thermostat mode (*two* jumper setting) the burners will fire on first-stage heat. The combustion air inducer will operate on low speed and indoor blower will operate on low heat speed. The unit will switch to second-stage heat on call from the indoor thermostat. If there is a simultaneous call for W1 and W2 (first and second stage heat) the unit will fire on first stage heat and switch to second stage heat after 30 seconds of operation. See Sequence of Operation flow charts in the back of this manual for more detail.

TABLE 16

Two Stage Ignition / Blower Control Terminals	
120VAC Neutral	
LINE	Line 120VAC Neutral
XFMR	Transformer 120VAC Neutral
EAC	Electronic Air Cleaner 120VAC Neutral
CIRC	Indoor Blower 120VAC Neutral
HUM	Humidifier 120VAC Neutral
120VAC Line	
HUM	Humidifier 120VAC Hot
XMFR	Transformer 120VAC Hot
LINE	Line 120VAC Hot
CIRC	Indoor Blower 120VAC Hot
EAC	Electronic Air Cleaner 120VAC Hot

TABLE 17

SureLight Board 5 Pin Terminal Designation	
PIN #	Function
1	Ignitor
2	Combustion Air Inducer High Speed
3	Combustion Air Inducer Low Speed
4	Combustion Air Inducer Neutral
5	Ignitor Neutral

TWO-STAGE, VARIABLE SPEED INTEGRATED CONTROL BOARD

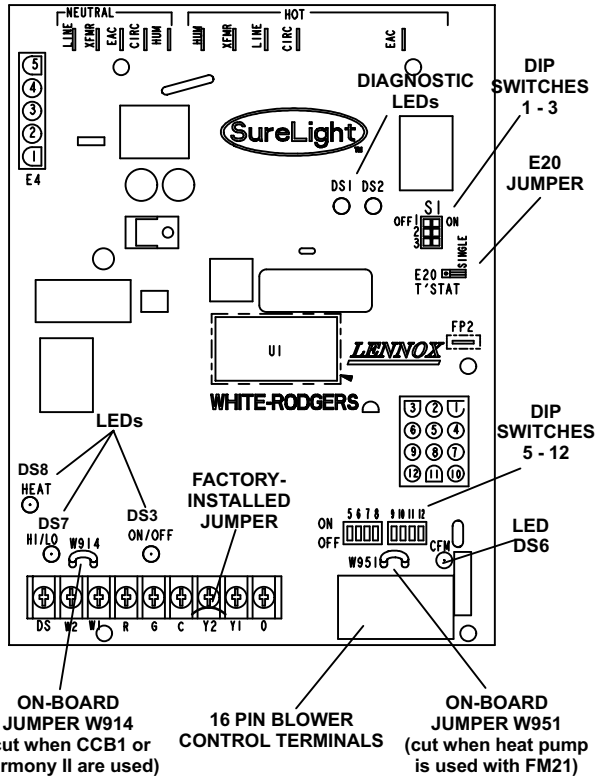

THERMOSTAT CONNECTIONS (TB1)

DS= DEHUMIDIFICATION SIGNAL
 W2= HEAT DEMAND FROM 2ND STAGE T'STAT
 W1= HEAT DEMAND FROM 1ST STAGE T'STAT (WHITE)
 R= CLASS 2 VOLTAGE TO THERMOSTAT
 G= MANUAL FAN FROM T'STAT (GREEN)
 C= THERMOSTAT SIGNAL GROUND CONNECTED TO TRANSFORMER GROUND (TR) & CHASIS GROUND (GRD)
 Y1= THERMOSTAT 1st STAGE COOL SIGNAL
 Y2= THERMOSTAT 2nd STAGE COOL SIGNAL
 O= THERMOSTAT SIGNAL TO HEAT PUMP REVERSING VALVE

DIP SWITCH FUNCTIONS

DIP SWITCH(ES)	FUNCTION
1 and 2	Blower Off Delay
3	Second Stage ON Delay (Single-stage t'stat)
4	Not used
5 and 6	Cooling Mode Blower Speed
7 and 8	Blower Speed Adjustment
9 and 10	Cooling Mode Blower Ramping Profile
11 and 12	Heating Mode Blower Speed

FIGURE 21

TABLE 18

SureLight Board 12Pin Terminal Designation	
PIN #	Function
1	Gas Valve 2nd. Stage (High Fire)
2	Second Stage Pressure Switch
3	Not Used
4	Ground
5	24V Hot
6	Primary Limit In
7	Gas Valve 1st. Stage (Low Fire)
8	Gas Valve Common
9	24V Neutral
10	Ground
11	Primary Limit Out
12	1st Stage Pressure Switch

TABLE 19

SureLight Board 16 Pin Blower Control Terminals	
PIN #	Function
1	Ground
2	Low Heat Speed
3	Ground
4	"DELAY" Dip Switch Selection
5	"COOL" Dip Switch Selection
6	"Y1" Signal
7	"ADJUST" Dip Switch Selection
8	Ground
9	"O" From Thermostat
10	"DS" Output Signal
11	"HEAT" Dip Switch Selection
12	24 VAC
13	HIGH HEAT Speed
14	"Y2" Signal
15	"G"
16	CFM LED

TABLE 20

STATUS CODES		
STATUS LED	COLOR	FUNCTION
DS3 "ON / OFF "	GREEN	DS3-ON indicates that the motor has a demand to operate. (This LED must be on in all modes).
DS6 "CFM"	GREEN	DS6-blinking indicates the airflow (CFM) demand in the motor. The air flow is determined by counting blinks between two (2) second pauses. One blink equals roughly 100 CFM.
DS7 "HI / LO"	YELLOW	DS7-ON indicates the "DS to R" jumper has not been cut. When the jumper is cut the system will be operating with LENNOX HARMONY II™ (See Harmony Installation Instructions) or with the CCB1 Efficiency Plus control. CCB1: When ON, a 24 VAC is being applied and when OFF, it has been removed. This on/off operation varies the indoor blower's performance so dehumidification can be enhanced.
DS8 "HEAT"	YELLOW	DS8-ON indicates the sytem is in HEAT mode.

TABLE 21

DIAGNOSTIC CODES		
Diagnostic LEDs are labeled DS1 and DS2. See figure 21 for location of diagnostic LEDs.		
DS1	DS2	DESCRIPTION
SIMULTANEOUS SLOW FLASH	SIMULTANEOUS SLOW FLASH	Power on - Normal operation. Also signaled during cooling and continuous fan.
SIMULTANEOUS FAST FLASH	SIMULTANEOUS FAST FLASH	Normal operation - signaled when heating demand initiated at thermostat.
SLOW FLASH	ON	Primary, secondary or rollout limit switch open. Limits must close within 3 minutes or unit goes into 1 hour Watchguard.
OFF	SLOW FLASH	Pressure switch open; OR: Blocked inlet/exhaust vent; OR: Pressure switch closed prior to activation of combustion air inducer.
OFF	FAST FLASH	Pressure switch open; OR: Blocked inlet/exhaust vent; OR: Pressure switch closed prior to activation of combustion air inducer.
ALTERNATING SLOW FLASH	ALTERNATING SLOW FLASH	Watchguard -- burners failed to ignite; OR limit open more than 3 minutes; OR lost flame sense 5 times in one heating cycle; OR pressure switch opened 5 times in one heating cycle.
SLOW FLASH	OFF	Flame sensed without gas valve energized.
ON ON OFF	ON OFF ON	Circuit board failure or control wired incorrectly. Check 24 and 115 volts to board.
FAST FLASH	SLOW FLASH	Main power polarity reversed. Switch line and neutral.
SLOW FLASH	FAST FLASH	Low flame signal. Measures below 0.23 microAmps. Replace flame sense rod.
ALTERNATING FAST FLASH	ALTERNATING FAST FLASH	The following conditions are sensed during the ignitor warm-up period only: 1) Improper main ground; 2) Broken ignitor; OR: Open ignitor circuit; 3) Line voltage below 75 volts. (If voltage lower than 75 volts prior to ignitor warm-up, control will signal waiting on call from thermostat, and will not respond.

NOTE - Slow flash rate equals 1 Hz (one flash per second). Fast flash rate equals 3 Hz (three flashes per second). Minimum flame sense current = 0.17-0.22 microAmps.

Dip Switch Settings

Switches 1 and 2 - Blower Off Delay The blower-on delay of 45 seconds is not adjustable. The blower-off delay (time that the blower operates after the heating demand has been satisfied) can be adjusted by moving switches 1 and 2 on the integrated control board. The unit is shipped from the factory with a blower-off delay of 90 seconds. The blower off delay affects comfort and is adjustable to satisfy individual applications. Adjust the blower off delay to achieve a supply air temperature between 90° and 110°F at the exact moment that the blower is de-energized. Longer off delay settings provide lower supply air temperatures; shorter settings provide higher supply air temperatures. The table below provides the blower off timings that will result from different switch settings.

**TABLE 22
Blower Off Delay Switch Settings**

Blower Off Delay (Seconds)	Switch 1	Switch 2
60	Off	Off
90	Off	On
120	On	Off
180	On	On

Switch 3 - Second Stage Delay (Used with Single-Stage Thermostat Only) This switch is used to determine the second stage on delay when a single-stage thermostat is being used. The switch is factory-set in the ON position, which provides a 10-minute delay before second-stage heat is initiated. If the switch is toggled to the OFF position, it will provide a 15-minute delay before second-stage heat is initiated. This switch is only activated when the thermostat selector jumper is positioned for SINGLE-stage thermostat use.

Switch 4 - Not used

Switches 5 and 6 - Cooling Mode Blower Speed Switches 5 and 6 are used to select cooling blower motor speed. The unit is shipped from the factory with the dip switches positioned for high speed (4) indoor blower motor operation during the cooling mode. The table below provides the cooling mode blower speeds that will result from different switch settings. Refer to blower data tables at the front of this manual for corresponding cfm values.

**TABLE 23
Cooling Mode Blower Speeds**

Speed	Switch 5	Switch 6
1 - Low	On	On
2 - Medium Low	Off	On
3 - Medium High	On	Off
4 - High (Factory)	Off	Off

Switches 7 and 8 - Blower Speed Adjustment Switches 7 and 8 are used to select blower speed adjustment settings. The unit is shipped from the factory with the dip switches positioned for NORMAL (no) adjustment. The dip switches may be positioned to adjust the blower speed by +10% or -10% to better suit the application. The table below provides blower speed adjustments that will result from different switch settings. Refer to blower data tables at the front of this manual for corresponding cfm values.

**TABLE 24
Blower Speed Adjustment**

Adjustment	Switch 7	Switch 8
+10% (approx.)	On	Off
NORMAL (Factory)	Off	Off
-10% (approx.)	Off	On

Switches 9 and 10 - Cooling Mode Blower Speed Ramping -- Switches 9 and 10 are used to select cooling mode blower speed ramping options. Blower speed ramping may be used to enhance dehumidification performance. The switches are factory set at option A which has the greatest effect on blower motor performance. The table below provides the cooling mode blower speed ramping options that will result from different switch settings. The cooling mode blower speed ramping options are detailed on the next page. See unit nameplate for manufacturing date.

**TABLE 25
Cooling Mode Blower Speed Ramping**

Ramping Option	Switch 9	Switch 10
A (Factory)	Off	Off
B	On	Off
C	Off	On
D*	On	On

*Only option for CCB1

GHR32V units manufactured before April 2003

Ramping Option A (Factory Selection)

- Motor runs at 50% for 1/2 minute.
- Motor then runs at 82% for approximately 7-1/2 minutes.
- If demand has not been satisfied after 7-1/2 minutes, motor runs at 100% until demand is satisfied.
- Once demand is met, motor runs at 50% for 1/2 minute.
- Motor ramps down to off.

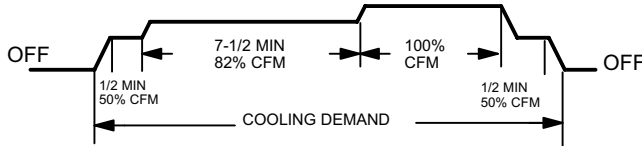

Ramping Option B

- Motor runs at 50% for 1/2 minute.
- Motor then runs at 82% for approximately 7-1/2 minutes.
- If demand has not been satisfied after 7-1/2 minutes, motor runs at 100% until demand is satisfied.
- Once demand is met, motor ramps down to off.

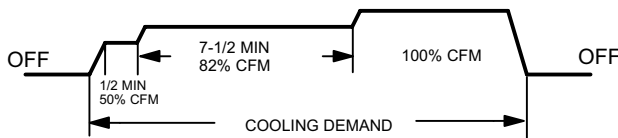

Ramping Option C

- Motor runs at 82% for approximately 7-1/2 minutes.
- If demand has not been satisfied after 7-1/2 minutes, the motor runs at 100% until demand is satisfied.
- Once demand is met, motor ramps down to off.

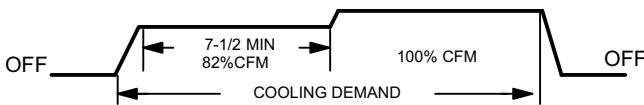

Ramping Option D

- Motor runs at 100% until demand is satisfied.
- Once demand is met, motor ramps down to off.

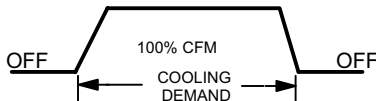

GHR32V units manufactured April 2003 and later

Ramping Option A (Factory Selection)

- Motor runs at 50% for 30 seconds.
- Motor then runs at 82% for approximately 7-1/2 minutes. If demand has not been satisfied after 7-1/2 minutes.
- Motor runs at 100% until demand is satisfied.
- Once demand is met, motor runs at 50% for 30 seconds then -
- ramps down to stop.

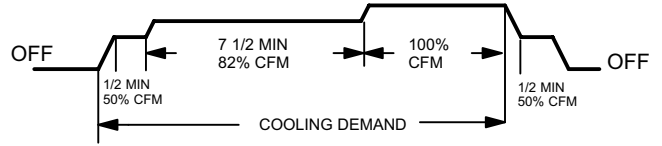

Ramping Option B

- Motor runs at 82% for approximately 7-1/2 minutes. If demand has not been satisfied after 7-1/2 minutes -
- motor runs at 100% until demand is satisfied.
- Once demand is met, motor ramps down to stop.

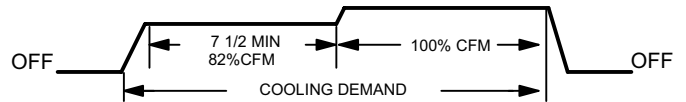

Ramping Option C

- Motor runs at 100% until demand is satisfied.
- Once demand is met, motor runs at 100% for 60 seconds. Then,
- ramps down to stop.

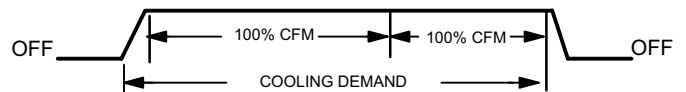

Ramping Option D

- Motor runs at 100% until demand is satisfied.
- Once demand is met, motor ramps down to stop.

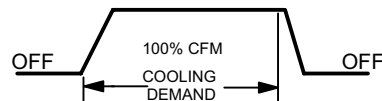

Switches 11 and 12 - Heating Mode Blower Speed

Switches 11 and 12 are used to select heating mode blower motor speed. The unit is shipped from the factory with the dip switches positioned for medium low (2) speed indoor blower motor operation during the heating mode. The table below provides the heating mode blower speeds that will result from different switch settings. Refer to blower data tables at the front of this manual for corresponding cfm values.

TABLE 26
Heating Mode Blower Speeds

Speed	Switch 11	Switch 12
1 - Low	On	On
2 - Medium Low (Factory)	Off	On
3 - Medium High	On	Off
4 - High	Off	Off

On-Board Jumper W914

On-board jumper W914, which connects terminals DS and R on the integrated control board, must be cut when the furnace is installed with either the Harmony II zone control board or the CCB1 EfficiencyPlus humidity control. Refer to table 27 for operation sequence in applications including a GHR32V, CCB1 and single-speed outdoor unit. Table 28 gives the operation sequence in applications with a two-speed outdoor unit.

On-Board Jumper W951

On-board jumper W951, which connects terminals R and O on the integrated control board, must be cut when the furnace is installed in applications which include a heat pump unit and the FM21 FuelMaster control board.

Factory-Installed Jumper Y1 to Y2

A factory-installed jumper from Y1 to Y2 terminals on the integrated control board terminal strip must be removed if two-stage cooling will be used.

Diagnostic LEDs (DS1 and DS2)

Two diagnostic LEDs are located on the two-stage, variable speed integrated control just to the left of the first bank of dip switches. These lights' flashes correspond with diagnostic codes detailed on in table 15.

Status LEDs (HEAT, HI/LO, ON/OFF and CFM)

The integrated control includes four LEDs which indicate operating status. The green ON/OFF LED is lit any time the blower is operating. The green CFM LED indicates the blower motor speed. Count the number of blinks between the two-second pauses to determine the CFM. Each blink represents approximately 100 CFM. The yellow HI/LO LED is lit when the W914 (DS to R) jumper **has not** been clipped for CCB1 or Harmony operation. The yellow HEAT LED is lit when the indoor blower is operating at the HEATING speed.

Table 27
Operating Sequence
GHR32V-5, CCB1 and Single-Speed Outdoor Unit

OPERATING MODE System Condition	SYSTEM DEMAND		SYSTEM RESPONSE	
	Thermostat Demand	*Relative Humidity (EfficiencyPlus Lights)	Blower CFM (COOL)	Comments
Normal operation	Y1	No demand. Humidity level is acceptable	COOL	Compressor demand and indoor blower speed controlled by thermostat demand.
*Call for humidity removal during cooling demand	Y1	Humidity level rises above setpoint. Demand initiated.	77%/74% of COOL	Call for dehumidification initiated by CCB1 control. Indoor blower speed reduced by CCB1 control.
Dehumidification demand satisfied during cooling demand.	Y1	Humidity level falls below setpoint. No demand	COOL	When humidity demand is satisfied, blower speed immediately increases to the COOL CFM to hasten the end of the cycle.
Call for cooling after call for humidity removal.	None	Humidity level above setpoint. Demand initiated.	Off	Dehumidification mode begins when relative humidity is greater than setpoint.
	Y1	Humidity level above setpoint. Demand initiated.	77%/74% of COOL	
Humidity demand satisfied between thermostat demands (unit off cycle).	None	Over setpoint (1 or more)	Off	While unit is not operating (no thermostat demand), slide switch is moved down and back up. Blower operates at COOL CFM.
	Y1	Change to acceptable	COOL	

NOTE - When changing unit mode of operation from cooling to heating, indicating lights that are on will stay on until the first thermostat heating demand.

* Reduced blower speed is 77% of COOL for V3 units and 74% of COOL for the V5 units.

**Table 28
Operating Sequence
GHR32V-5, CCB1 and Two-Speed Outdoor Unit**

OPERATING MODE System Condition	SYSTEM DEMAND		SYSTEM RESPONSE		
	Thermostat Demand	*Relative Humidity (EfficiencyPlus Lights)	****Compressor Speed	Blower CFM (COOL)	Comments
Normal operation	Y1	No demand. Acceptable	Low	55% of HIGH COOL	Compressor demand and indoor blower speed controlled by thermostat demand
	Y2	No demand. Acceptable	High	HIGH COOL	
Call for humidity removal during 1st-stage cooling demand	Y1	No demand. Acceptable	Low	55% of HIGH COOL	Dehumidification mode does not begin until after initial thermostat demand is satisfied and new cooling demand is initiated.
	Y1	Humidity level rises slightly (1) above setpoint. Demand initiated.	Low	55% of HIGH COOL	
	Demand satisfied	Humidity level remains slightly (1) above setpoint. Demand continues.	Off	Off	
	Y1	Humidity level remains slightly (1) above setpoint. Demand continues.	High	**77%/74% of HIGH COOL	
Significant increase in humidity during thermostat cooling demand.	Y1	No demand. Acceptable	Low	55% of HIGH COOL	If humidity rises significantly above setpoint, or if slide switch is moved significantly, unit will immediately go into dehumidification mode (in presence of thermostat demand).
	Y1	Humidity level rises significantly (2 or more) above setpoint. Demand initiated.	High	**77%/74% of HIGH COOL	
Humidity demand satisfied during thermostat demand.	Y1	Humidity level above setpoint.	High	**77%/74% of HIGH COOL	When humidity demand is satisfied, blower immediately shifts to the COOL CFM in order to hasten the end of the cycle. Unit can only shift out of high speed compressor operation at beginning of next cycle.
	Y1	Humidity level falls below setpoint. No demand.	High	HIGH COOL	
	None	No demand. Acceptable	Off	Off	
	Y1	No demand. Acceptable	Low	55% of HIGH COOL	
Call for humidity removal during 2nd stage thermostat demand	Y2	No demand. Acceptable	High	HIGH COOL	Blower immediately changes speed in response to thermostat demand.
	Y2	Humidity level rises slightly (1) above setpoint. Demand initiated.	High	**77%/74% of HIGH COOL	
	Y2	No demand. Acceptable	High	HIGH COOL	
*Call for 1st stage cooling after call for humidity removal.	None	Humidity level is slightly (1) above setpoint.	Off	Off	Dehumidification mode (high speed compressor) begins with next thermostat demand after initial demand is satisfied.
	Y1	Humidity level is slightly (1) above setpoint.	Low	55% of HIGH COOL	
Call for 2nd stage cooling after call for humidity removal	None	Humidity level is slightly (1) above setpoint.	Off	Off	Reduced blower speed (dehumidification speed) begins immediately with thermostat demand
	Y2	Humidity level is slightly (1) above setpoint.	High	**77%/74% of HIGH COOL	
Call for cooling after significant increase in humidity	None	Humidity level is significantly above setpoint (2 or more).	Off	Off	If humidity increases significantly over setpoint, or if slide switch is moved, unit immediately goes into dehumidification mode (in presence of thermostat demand).
	Y1 or Y2	Humidity level is significantly above setpoint (2 or more).	High	**77%/74% of HIGH COOL	
Humidity demand satisfied between thermostat demands (unit off cycle).	None	Humidity level is slightly (1) above setpoint.	Off	Off	While unit is not operating (no thermostat demand), slide switch is moved down and back up. Blower and compressor operate at high speed until next thermostat demand.
	Y1 or Y2	Humidity level falls below setpoint. No demand.	High	HIGH COOL	

Note - During mode of operation change from cooling to heating, indicating lights will not change until the first thermostat heating demand.

**IMPORTANT - If power to unit is turned on with CCB1 calling for humidity removal, outdoor unit may be locked into high speed indefinitely. To reset, move the humidity slide switch all the way down then back up to desired setpoint while the unit is running.*

*** Reduced blower speed is 77% of COOL for the V3 units; 74% of COOL for V5.*

****If the two-speed control on a two-speed outdoor unit is set for LATCH 2 (15 minutes) or LATCH 3 (30 minutes), the compressor will latch into high speed after a Y1 demand has occurred for that period of time.*

GHR32 HEAT EXCHANGER

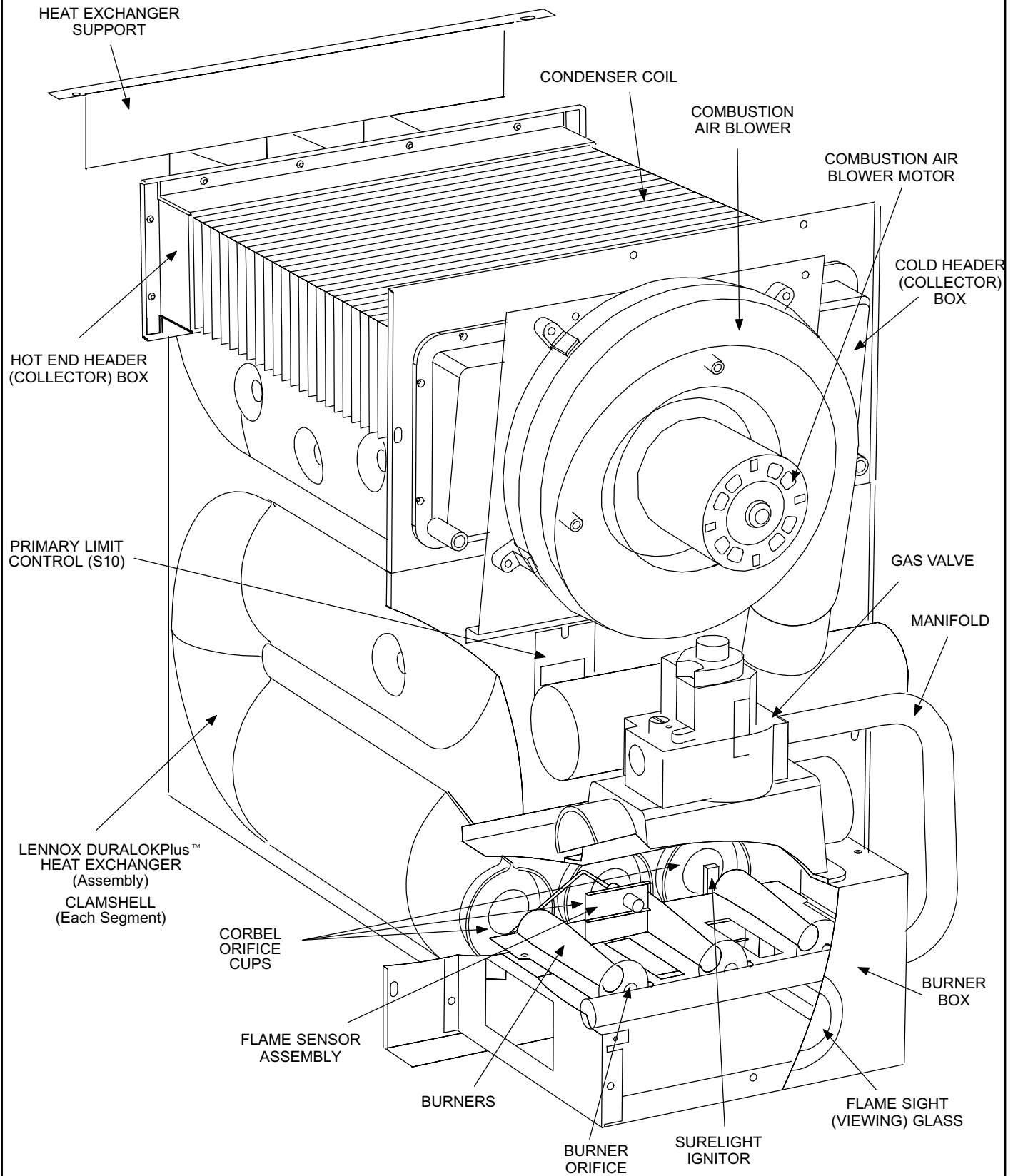

FIGURE 22

C-Heating Components (Figure 22)

Combustion air blower (B6), primary limit control (S10), SureLight ignitor, flame sensor, burners, flame rollout switch (S47), gas valve (GV1), combustion air blower switch (S18), and clamshell heat exchangers are located in the heating compartment. The heating compartment can be accessed by removing the burner access panel.

1. Combustion Air Inducer Blower (B6)

All GHR32 units use a two-stage combustion air inducer blower to move air through the burners and heat exchanger during heating operation. The blower uses a 120VAC motor. The motor operates during all heating operation and is controlled by the SureLight integrated board (A92) and two-stage control board (A86). The combustion air inducer blower operates on low speed during first stage heat (low fire), then switches to high speed for second stage heat (high fire).

2. Combustion Air Blower Capacitor (C3) PSC Motors only

GHR32 units with a PSC combustion air blower motor, will have a thermally protected 3 MFD 300VAC capacitor. The capacitor is mounted on the combustion air blower housing.

3. Primary Limit Control (S10)

Figure 23 shows the primary limit (S10) used on GHR32 units. S10 is located in the middle of the heating vestibule panel. When excess heat is sensed in the heat exchanger, the limit will open. If the limit is tripped, the furnace control energizes the supply air blower and closes the gas valve. The limit automatically resets when unit temperature returns to normal. The switch is factory set and cannot be adjusted. See table 29 for limit set points.

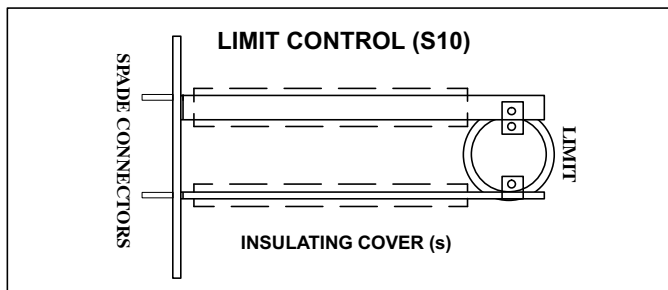

FIGURE 23

TABLE 29

GHR32 UNIT SIZE	LIMIT SET POINT
GHR32-50	300°
GHR32-75	300°
GHR32Q3/4-100	220°
GHR32-120	175°

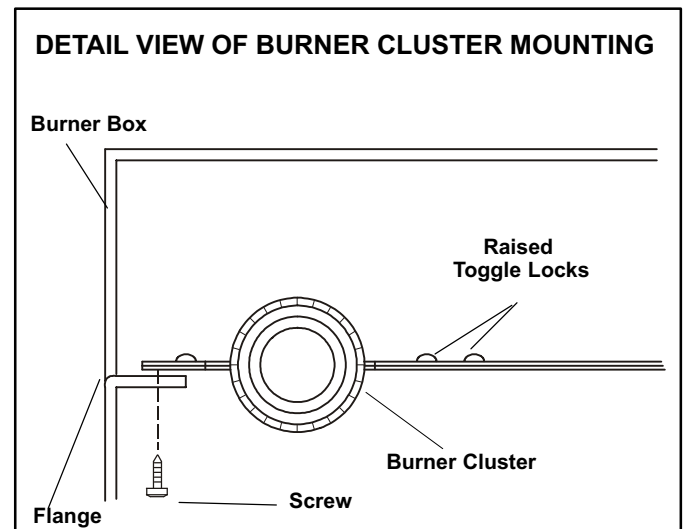

FIGURE 24

4. Burners

Figure 22 shows the arrangement of the burner box. Table 30 shows how many burners are used per unit. See figure 24 for a more detailed view. Notice the position of the raised toggle lockets.

TABLE 30

GHR32 UNIT SIZE	NUMBER OF HEAT EXCHANGER CLAMSHELLS / BURNERS
GHR32-50	2
GHR32-75	3
GHR32Q3/4-100	4
GHR32-120	5

All units use inshot burners. Burners are factory set and do not require adjustment. A sight glass is furnished in the burner box assembly for flame viewing. Always operate the unit with the burner box cover in place. Burners can be removed as an assembly for service. Burner maintenance and service is detailed in the SERVICE CHECKS sections of this manual. Each burner uses an orifice which is precisely matched to the burner input. The orifice is threaded into the burner manifold. The burner is supported by the orifice and will easily slide off for service. Each orifice and burner are sized specifically to the unit. Refer to Lennox Repair Parts Listing for correct sizing information. A flame retention ring in the end of each burner maintains correct flame length and shape and keeps the flame from lifting off the burner head. In addition, the burner entrance to each clamshell (Figure 22) is fitted with a corbel cup (orifice) used to direct the flow of combustion products.

NOTE-Do not use thread-sealing compound on the orifices. Thread-sealing compound may plug the orifices.

5. Clamshell Heat Exchanger

GHR32 units use an aluminized steel primary and stainless steel secondary heat exchanger assembly. Table 30 shows how many heat exchanger clamshells are used per unit. Heat is transferred to the air stream from all surfaces of the heat exchanger. The shape of the heat exchanger ensures maximum efficiency.

The combustion air blower pulls fresh air through the air intake box. This air is mixed with gas in the burner venturi and at the corbel orifices. The gas / air mixture is then burned at the entrance of each clamshell. Combustion gases are then pulled through the primary and secondary heat exchangers and exhausted out the exhaust vent pipe.

6. Flame Rollout Switch (S47)

Flame rollout switch S47 is a SPST N.C. high temperature limit located behind the burner air intake fitting on the burner box assembly (see figure 25). S47 is wired to the burner ignition control A3. When S47 senses flame rollout (indicating a blockage in the combustion air passages), the flame rollout switch trips, and the ignition control immediately closes the gas valve.

Switch S47 in all GHR32 units is factory preset to open at $320^{\circ}\text{F} \pm 12^{\circ}\text{F}$ ($160^{\circ}\text{C} \pm 6.7^{\circ}\text{C}$) on a temperature rise. All flame rollout switches are manually reset.

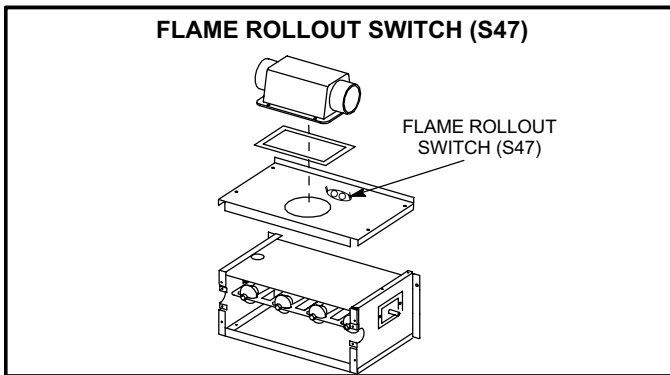

FIGURE 25

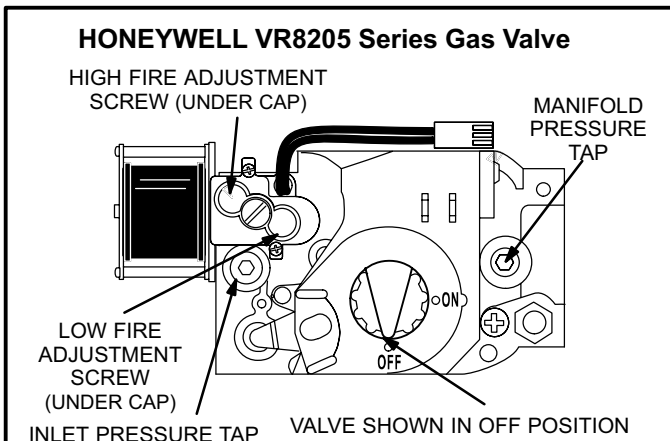

FIGURE 26

7. Gas Valve

The GHR32 uses a gas valve manufactured by White Rodgers or Honeywell. The valve is two-stage internally redundant to assure safety shut-off. If the gas valve must be replaced, the same type valve must be used. The Honeywell valve can be field converted to LP and is adjustable on both low and high fire. White Rodgers supplies two separate valves for natural and LP and is adjustable for high fire ONLY.

24VAC terminals and gas control knob are located on top of the valve. Terminals on the gas valve are connected to wires from the SureLight integrated control and the two-stage control. 24V applied to the terminals energizes the valve.

Inlet and outlet pressure taps are located on the valve. A regulator adjustment screw is located on the side of the valve. Refer to figures 26, 27, and 28 for location of valve features.

NOTE-White Rodgers valve is not adjustable on low fire. Do not attempt to regulate low fire manifold pressure.

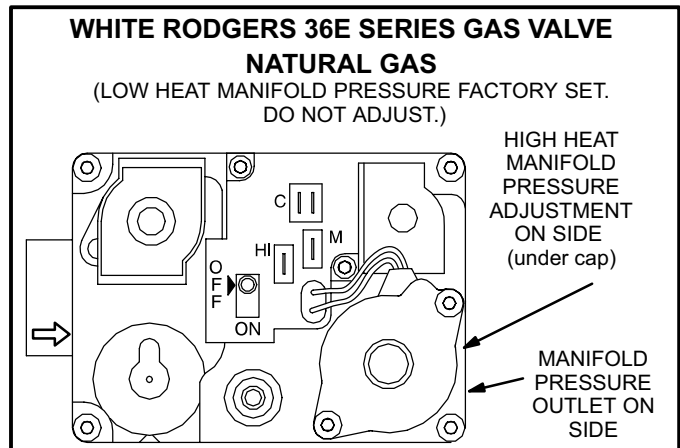

FIGURE 27

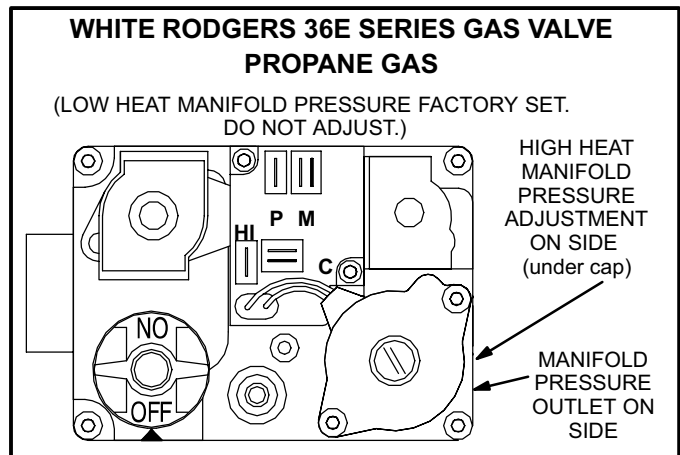

FIGURE 28

100% Sealed Combustion

The burner box is completely sealed and operates under a negative pressure. A pressure hose is connected from the burner box to the gas valve regulator. The gas valve senses the pressure in the burner box and changes gas valve outlet (manifold) pressure based on changes in burner box pressure. The intent is to compensate for different vent configurations which can greatly affect the firing rate of the unit.

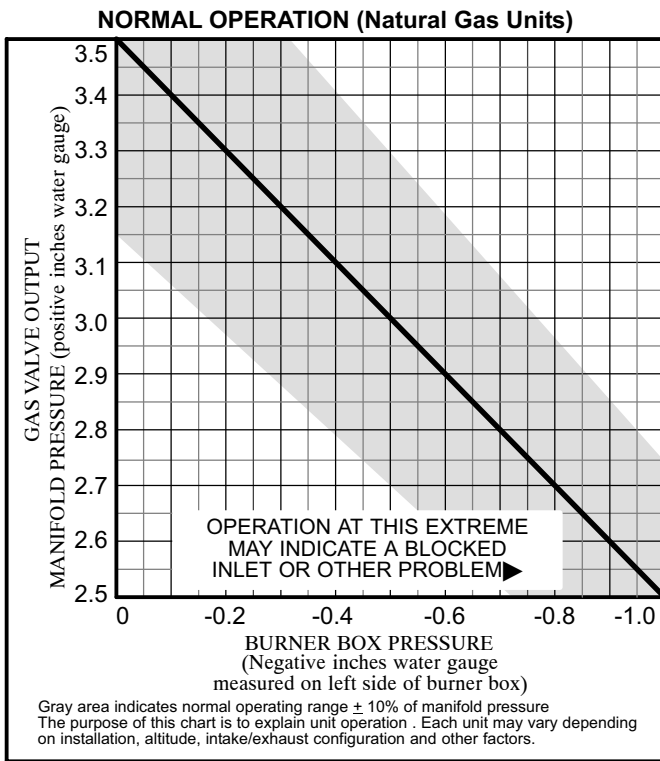

FIGURE 29

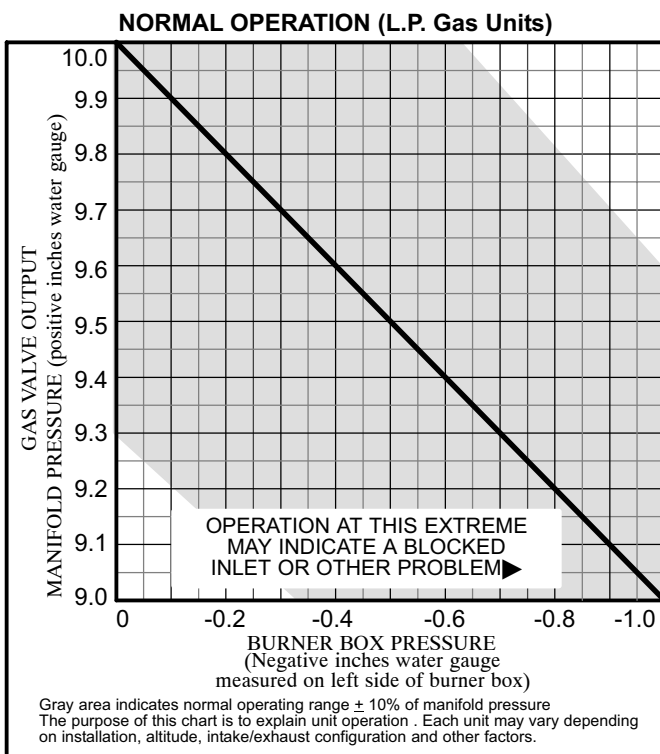

FIGURE 30

Figures 29 and 30 show how gas valve manifold pressure changes as burner box pressure changes. The GHR32 is a self adjusting unit to maintain a constant output.

8. Combustion Air Prove Switch (S18) GHR32-1/-4 Units & (S102) GHR32-5 Units

GHR32 series units are equipped with a differential pressure switch S18 or S102 located on either side of the heating compartment cabinet (factory installed on left side). The switch monitors the differential pressure between the downstream and upstream flue gas pressures. When the unit is installed for horizontal right-hand discharge, the air proving pressure switch must be moved to the opposite side of the unit. Any one of four different switches may be on the unit. One is manufactured by MPL. The other three switches are manufactured by TRIDELTA / HONEYWELL. Each switch operates the same and can be replaced with one another. See figure 31 for combustion air prove switch replacement. **Hoses must be connected to correct taps for switch to operate safely and properly.** GHR32 model units have color coded tubing to designate positive and negative sides of the pressure switch. Red/Square tubing should always be connected to the positive side of the pressure switch. Gray or Black /Round tubing should always be connected to the negative side of the pressure switch. See figure 31.

The switch is a SPST N.O. pressure switch electrically connected to the integrated control. The purpose of the switch is to prevent burner operation if the combustion air blower is not moving enough air for proper combustion.

On start-up, the switch senses that the combustion air blower is operating. It closes a circuit to the ignition control when the difference in pressure across the pressure switch exceeds 0.90" W.C. (223.78Pa). If the switch does not successfully sense the required differential, the switch cannot close and the furnace cannot operate. The switch is factory set and is not adjustable. If the flue or air inlet become obstructed during operation, the switch senses a loss of pressure differential and opens the circuit to the ignition control. If the condensate line is blocked, water will back up into the header box and reduce the pressure differential across the switch. The pressure switch will open if the differential drops below 0.75" W.C. ± 05 " W.C. (186.48 Pa ± 12.4 Pa).

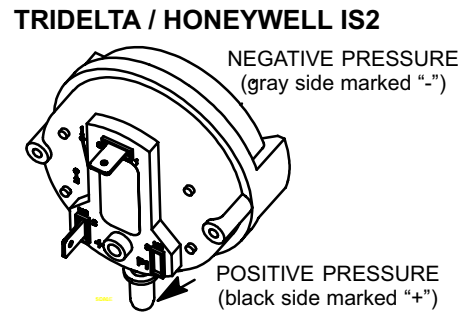
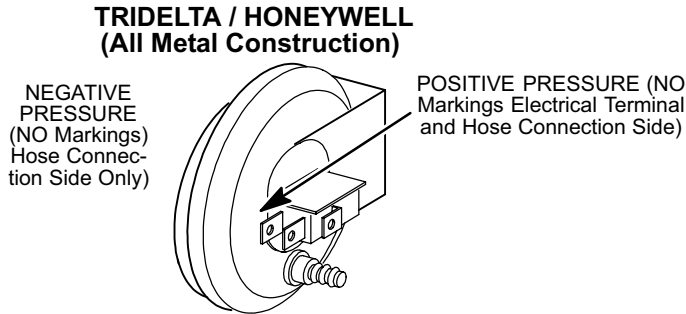
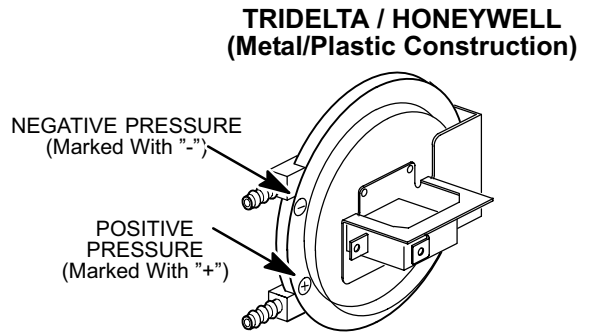
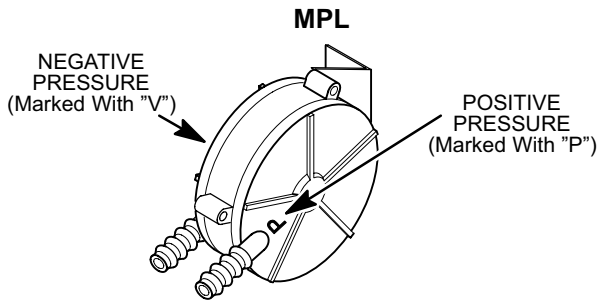

HORIZONTAL LEFT HAND AIR DISCHARGE

Connect hose (red square) to POSITIVE side on pressure switch and open tap on FRONT of collector box.

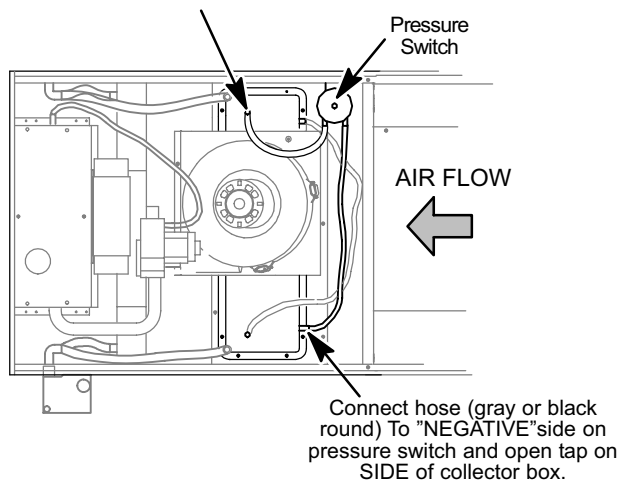

DOWN FLOW AIR DISCHARGE

Connect hose (gray or black round) To NEGATIVE side on pressure switch and open tap on FRONT of collector box.

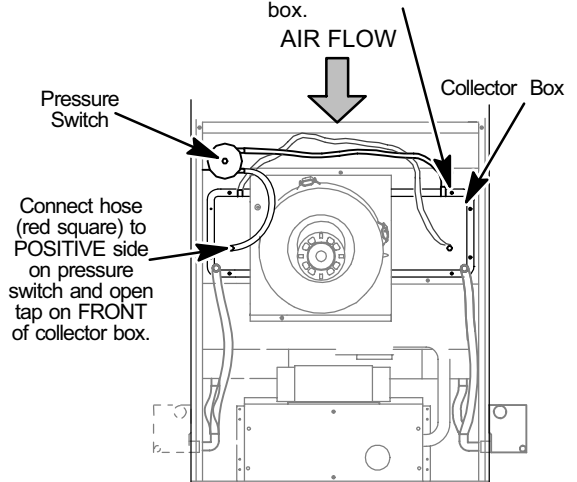

HORIZONTAL RIGHT HAND DISCHARGE

Connect the red square hose to the POSITIVE side on pressure switch and the open tap on the FRONT of the collector box.

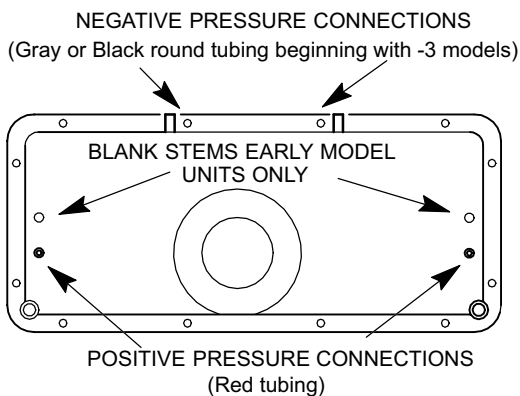
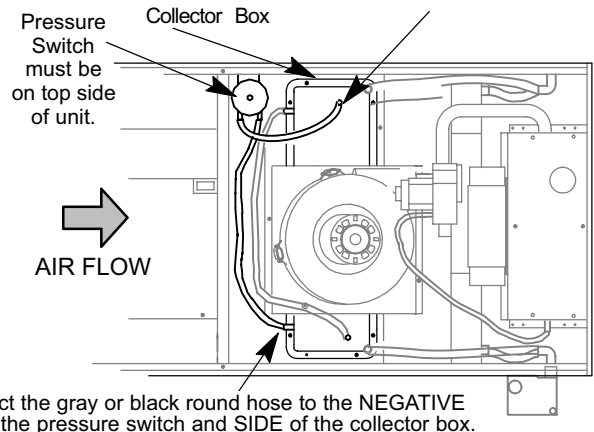

FIGURE 31

To troubleshoot the pressure switch, temporarily jumper the switch. The unit will not fire with pressure switch jumpered. Therefore, the pressure switch must be bypassed after the combustion air blower is activated. This will determine if the pressure switch and furnace are operating properly. However, this may not indicate if the sealed combustion system is operating properly. If the unit cannot attain 0.75" W.C. (186.48 Pa) differential, the unit will not operate.

⚠ IMPORTANT

Unit will not operate with pressure switch bypassed upon start-up. To troubleshoot pressure switch, jumper pressure switch following activation of combustion air blower!!

Checks of pressure differential can aid in troubleshooting. When measuring the pressure differential, readings should be taken at the pressure switch. Lack of differential usually indicates problems in the intake or exhaust piping, but may indicate problems in the heat exchanger, condensing coil, header boxes, combustion blower or other components.

Measuring pressure differential

The differential pressure is the difference in pressure measured on either side of the pressure switch:

- 1 - Remove thermostat demand and allow unit to cycle off.
- 2 - Disconnect hose from front of pressure switch and install tee as shown in figure 32. Repeat sequence for hose connected to back of switch.

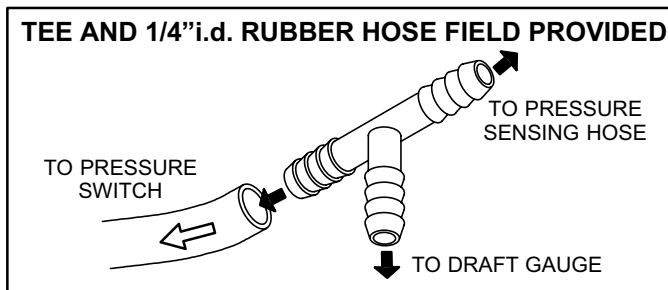

FIGURE 32

- 3 - Install manometer (draft gauge) to open ends of tee's. The hose from the back side of the switch goes to the zero side of the gauge.
- 4 - Operate unit and observe draft gauge reading. *Readings will change as heat exchanger warms.*
 - a. Take one reading immediately after startup.
 - b. Take a second reading after unit has reached steady state (approximately 5 minutes).

Pressure differential should be greater than .75" W.C. (186.48 Pa).

- 5 - Remove thermostat demand and allow to cycle off.
- 6 - Remove draft gauge and Tee's. Reinstall combustion air sensing hoses to the pressure switch.

D-Blower Compartment (Figures 33 and 34)

Blower motor (B3), capacitor (C4), and secondary limit control (S21) are located in the blower compartment shown in figure 33. Blower motor (B3), Coil choke (L13) and secondary limit (S21) are shown in figure 34. The blower compartment can be accessed by removing the blower access panel.

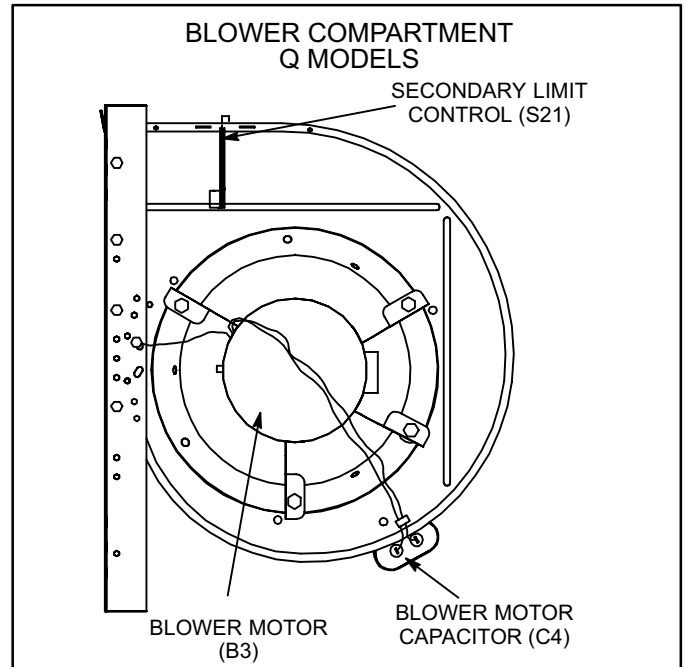

FIGURE 33

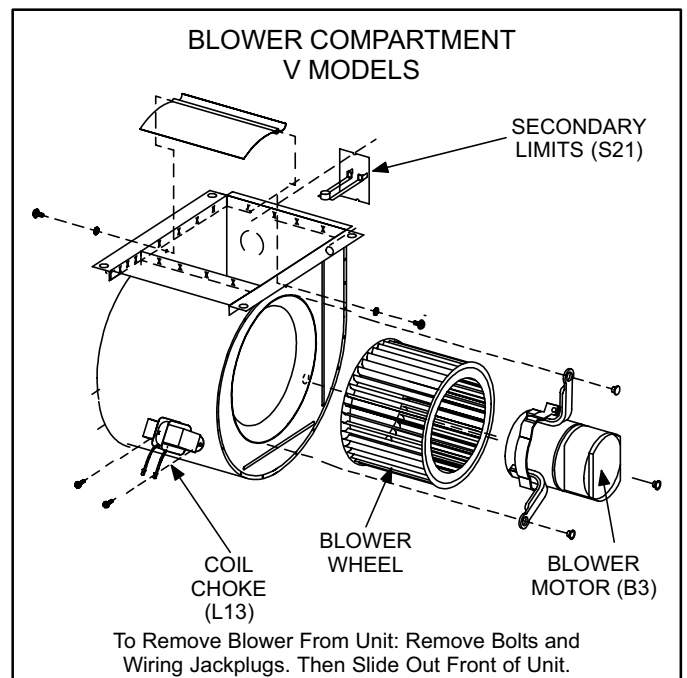

FIGURE 34

1. Blower Motor (B3) and Capacitor (C4) GHR32Q Models

All GHR32Q model units use single phase direct drive blower motors. All motors are 120V permanent split capacitor motors to ensure maximum efficiency. See motor nameplate or SPECIFICATIONS section for motor ratings. Ratings for capacitor will be on side.

2. Secondary Limit Control (S21)

The secondary limit (S21) on GHR32 units is mounted on the back side of the blower housing. When excess heat is sensed in the blower compartment, the limit will open. If the limit is tripped, the furnace control energizes the supply air blower and closes the gas valve. The limit automatically resets when unit temperature returns to normal. The switch opens at $160^{\circ}\text{F} \pm 5^{\circ}\text{F}$ ($71.1^{\circ}\text{C} \pm 2.8^{\circ}\text{C}$) on a temperature rise and resets at $130^{\circ}\text{F} \pm 8^{\circ}\text{F}$ ($54.4^{\circ}\text{C} \pm 4.4^{\circ}\text{C}$) on a temperature fall. The switch is factory set and cannot be adjusted. The setpoint is printed on the face plate of the limit.

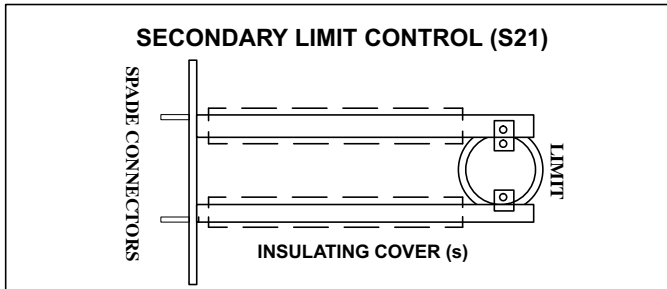

FIGURE 35

3. Blower Motor (B3) GHR32V MODELS

GHR32V model units use a single-phase, electronically controlled D.C. brushless motor (controller converts single phase A.C. to three phase D.C.), with a permanent-magnet-type rotor (figure 36). Because this motor has a permanent magnet rotor it does not need brushes like conventional D.C. motors. Internal components are shown in figure 37. The stator windings are split into three poles which are electrically connected to the controller. This arrangement allows motor windings to turn on and off in sequence by the controller.

DANGER

Disconnect power from unit and wait at least five minutes to allow capacitors to discharge before attempting to adjust motor speed tap settings. Failure to wait may cause personal injury or death.

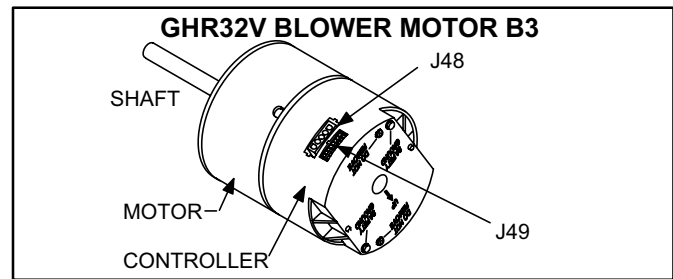

FIGURE 36

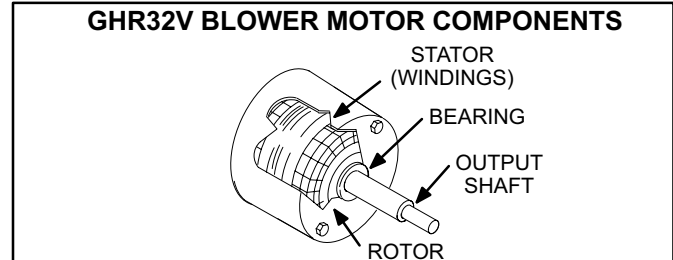

FIGURE 37

A solid-state controller is attached to the motor. The controller is primarily an A.C. to D.C. converter. Converted D.C. power is used to drive the motor. The controller contains a microprocessor which monitors varying conditions inside the motor (such as motor workload).

The controller uses sensing devices to sense what position the rotor is in at any given time. By sensing the position of the rotor and then switching the motor windings on and off in sequence, the rotor shaft turns the blower.

GHR32V series blower motor ratings are listed in the SPECIFICATIONS section. All GHR32V blower motors use single phase power. An external run capacitor is not used. The motor uses permanently lubricated ball-type bearings. The VSM is a two part component; the motor and the control module. If motor fails, it is quite possible the control module only, will need to be replaced. Lennox provides a replacement kit for the control module.

Internal Operation

Each time the controller switches a stator winding (figure 37) on and off, it is called a "pulse." The length of time each pulse stays on is called the "pulse width." By varying the pulse width (figure 38), the controller varies motor speed (called "pulse-width modulation"). This allows for precise control of motor speed and allows the motor to compensate for varying load conditions as sensed by the controller. In this case, the controller monitors the static workload on the motor and varies motor rpm in order to maintain constant airflow (cfm).

The motor is equipped with 11 incremental taps which are driven by the integral controller. The controller is capable of controlling three of the 11 taps.

The motor controller is driven by the VSP2-1, VSP3-1 or two stage integrated SureLight control. The VSP receives its demand (PWM signal or fixed 24 VAC or VDC signal) from optional controls such as the Harmony zone control system, Efficiency Plus Humidity Control (CCB1) or a conventional thermostat.

Motor rpm is continually adjusted internally to maintain constant static pressure against the blower wheel. The controller monitors the static work load on the motor and motor amp-draw to determine the amount of rpm adjustment. Blower rpm may be adjusted any amount in order to maintain a constant cfm as shown in Blower Ratings Tables. The amount of adjustment is determined by the incremental taps which are used and the amount of motor loading sensed internally. The cfm remains relatively stable over a broad range of static pressure. Since the blower constantly adjusts rpm to maintain a specified cfm, motor rpm is not rated. Hence, the terms "blower speed" and "speed tap" in this manual, on the unit wiring diagram and on blower B3 refer to blower cfm regardless of motor rpm.

When Harmony is used, speed taps are overridden and a PWM signal generated by the Harmony controller continuously varies motor speed based upon zone demands.

Initial Power Up

When line voltage is applied to B3, there will be a large inrush of power lasting less than 1/4 second. This inrush charges a bank of DC filter capacitors inside the controller. If the disconnect switch is bounced (rapid turning on and off) when the disconnect is closed, the disconnect contacts may become welded. Try not to bounce the disconnect switch when applying power to the unit.



Motor Start-Up

When B3 begins start-up, the motor gently vibrates back and forth for a moment. This is normal. During this time the electronic controller is determining the exact position of the rotor. Once the motor begins turning, the controller slowly eases the motor up to speed (this is called "soft-start"). The motor may take as long as 10-15 seconds to reach full speed. If the motor does not reach 200rpm within 13 seconds, the motor shuts down. Then the motor will immediately attempt a restart. The shutdown feature provides protection in case of a frozen bearing or blocked blower wheel. The motor may attempt to start eight times. If the motor does not start after the eighth try, the controller locks out. Reset controller by momentarily turning off power to unit.

The DC filter capacitors inside the controller are connected electrically to the speed tap wires. **The capacitors take approximately 5 minutes to discharge when the disconnect is opened. For this reason it is necessary to wait at least 5 minutes after turning off power to the unit before attempting to change speed taps.**

MOTOR SPEED CONTROL WITH D.C. PULSE-WIDTH MODULATION

Motor speed is determined by the size of the electrical pulse sent to the motor windings. The longer the pulse, the faster the motor.

OUTPUT FROM CONTROLLER TO MOTOR WINDINGS	
WINDINGS TURNED OFF	WINDINGS TURNED ON
	 ON PULSE  OFF PULSE

The frequency of the pulses to the windings is 20KHz.
DO NOT ATTEMPT TO MEASURE THESE VOLTAGES.

LOW SPEED HEAT/COOL (output from controller to motor windings)

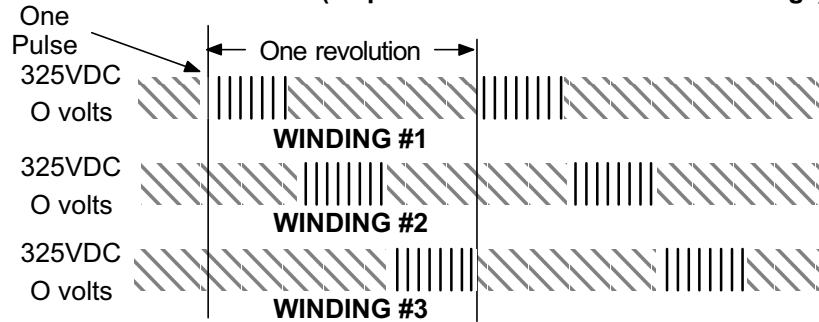

HIGH SPEED HEAT (output from controller to motor windings)

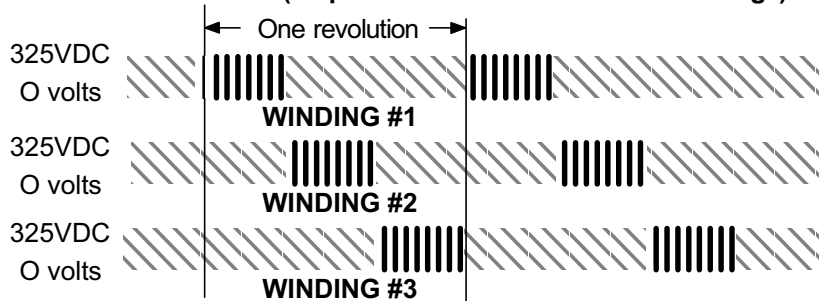

HIGH SPEED COOL (output from controller to motor windings)

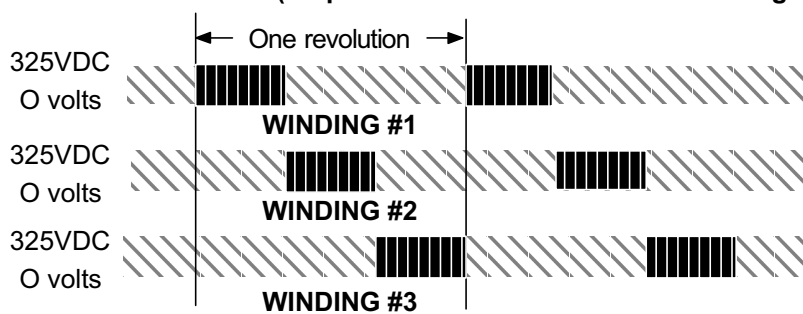

FIGURE 38

External Operation (Speed Tap Priority)

Figure 39 shows the two quick-connect jacks (J48 and J49) which connect the motor to the GHR32V. Jack J48 is the power plug and jack J49 connects the unit controls to the motor.

Line voltage must be applied to J48 pin 5 in order for the motor to operate. When using 120VAC pins 1 and 2 must be jumpered. When control voltage is applied to J49 pin 3 and 15 (single stage heating and cooling), the motor is energized on the low speed heat/cool tap.

When voltage is applied to J49 pin 2 in addition to pin 3 and 15 (second stage heating), the blower is energized on the high speed heating tap. When voltage is applied to J49 pin 10 in addition to pin 3 and 15 (second stage cooling), the blower is energized on the high speed cooling tap. The motor assigns priority to J49 pin 2 so that if a call for cooling and a call for heating are concurrent, heating call overrides and the blower operates on high speed heating tap.

ICM2 with VSP3 or Two stage Variable Speed Control

The ICM2 operates slightly different than stated above when matched with the VSP3 or Two stage variable speed control. When control voltage is applied to J49 pin 3 and 15, the motor is energized on continuous fan. When voltage is applied to J49 pin 2 in addition to pin 3 and 15 (first stage heating), the blower is energized on the low speed heating tap. When voltage is applied to J49 pin 13 in addition to pin 3 and 15 (second stage heating), the blower is energized on the high speed heating tap. The motor assigns priority to J49 pin 2 so that if a call for cooling and a call for heating are concurrent, heating call overrides and the blower operates on high speed heating tap.

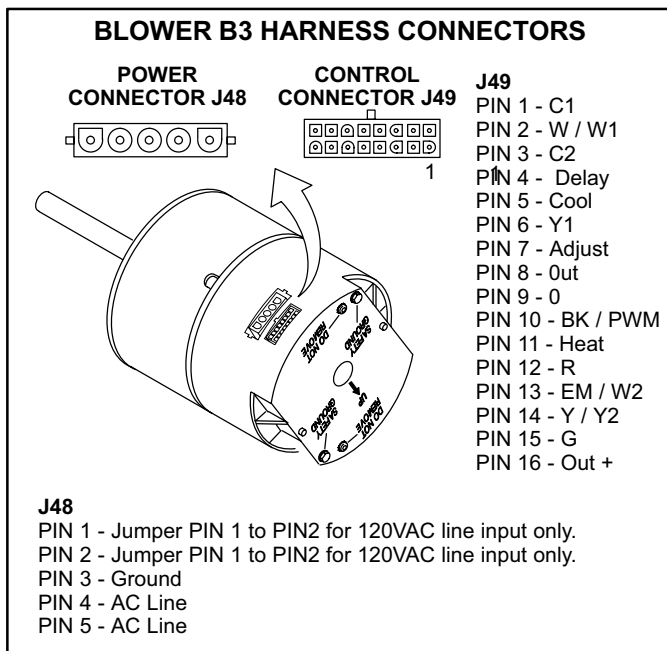

FIGURE 39

4. Choke Coil (L13)

A choke coil is used on all GHR32V units. The choke is located on the blower housing and is used to block radio frequency interference.

Precautions

If the GHR32 V or its electronically controlled blower motor is improperly or inadequately grounded, it may cause television interference (commonly known as RFI or radio frequency interference).

This interference is caused by internal switching frequencies of the motor controller (see figure 40). TV interference may show up as small specks or lines which randomly appear on the TV screen accompanied by pops or clicks in the sound. Before attempting any service, make sure the indoor unit is causing the interference. To check, disconnect power to indoor unit then check TV for continued signs of interference.

TV interference may be stopped by making sure the motor is solidly grounded to the cabinet (metal to metal) and by making sure the cabinet is solidly grounded. If TV interference persists, make sure the television (and all affected RF appliances) are moved away from the GHR32V. Also make sure affected appliances are connected to a separate electrical circuit.

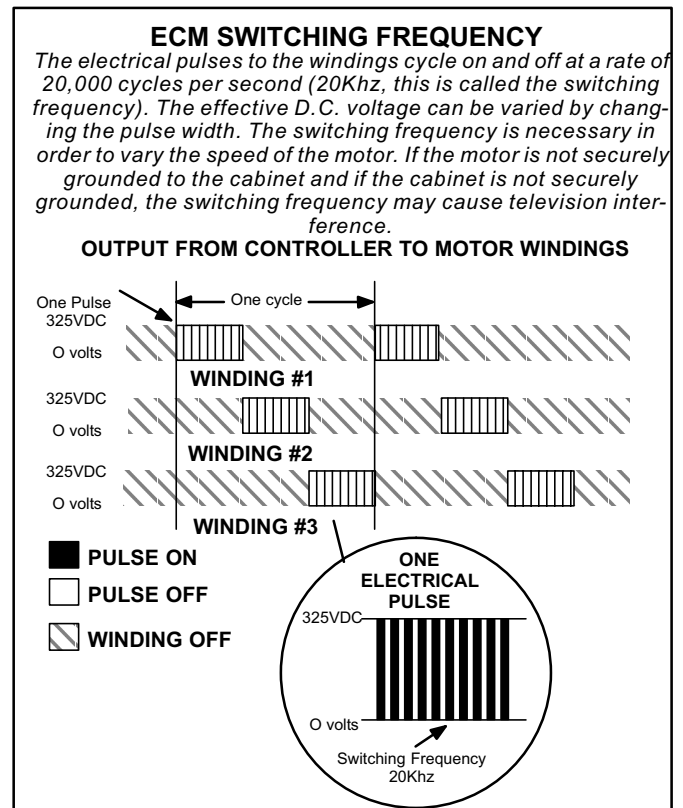

FIGURE 40

II-PLACEMENT AND INSTALLATION

Make sure unit is installed in accordance with installation instructions and applicable codes.

A-PVC Joint Cementing Procedure

WARNING

DANGER OF EXPLOSION! Fumes from PVC glue may ignite during system check. Remove spark plug wire from ignition control before 120V power is applied. Reconnect wire after two minutes.

- 1 - Measure and cut vent pipe to desired length.
- 2 - Debur and chamfer end of pipe, removing any ridges or rough edges. If end is not chamfered, edge of pipe may remove cement from fitting socket and result in a leaking joint.
- 3 - Clean and dry surfaces to be joined.
- 4 - Test fit joint and mark depth of fitting on outside of pipe.
- 5 - Uniformly apply liberal coat of PVC primer for PVC or ABS cleaner for ABS to inside socket surface of fitting and male end of pipe to depth of fitting socket.
- 6 - Promptly apply solvent cement to end of pipe and inside socket surface of fitting. Cement should be applied lightly but uniformly to inside of socket. Take care to keep excess cement out of socket. Apply second coat to end of pipe.

NOTE-Time is critical at this stage. Do not allow primer to dry before applying cement.

- 7 - Immediately after applying last coat of cement to pipe, and while both inside socket surface and end of pipe are wet with cement, forcefully insert end of pipe into socket until it bottoms out. Turn pipe 1/4 turn during assembly (but not after pipe is fully inserted) to distribute cement evenly. Once joint is made, PVC may swell. Hold joint together until bonded (approximately 20 seconds).

NOTE-Assembly should be completed within 20 seconds after last application of cement. Hammer blows should not be used when inserting pipe.

- 8 - After assembly, wipe excess cement from pipe at end of fitting socket. A properly made joint will show a bead around its entire perimeter. Any gaps may indicate a defective assembly due to insufficient solvent.
- 9 - Handle joints carefully until completely set.

B-Venting Considerations

All GHR32 furnaces must be vented independently as shown in figure 42 and must not be connected to a common venting system. If a GHR32 furnace replaces a less efficient furnace which was vented with other gas appliances into a common vent, the size of the common vent pipe must be appropriate for gas appliances which remain connected. Without the heat of the original furnace flue products, the vent pipe is probably oversized for the single water heater or other appliance(s). The common vent should be checked for proper draw for all appliance(s) which remain connected.

Checks of Common Venting System for Other Gas Appliances (Water Heater, etc...)

- 1 - Unused openings in the common venting system must be sealed.
- 2 - The venting system should be visually checked for proper size and horizontal pitch. You should also check and determine that there is no blockage or restriction, leakage, corrosion and other deficiencies which could cause an unsafe condition.
- 3 - Close all building doors and windows and all doors between the space in which the appliances remaining connected to the common venting system are located and other spaces of the building. Turn on clothes dryers and any appliances not connected to the common venting system. Turn on any exhaust fans, such as range hoods and bathroom exhausts, so they will operate at maximum speed. Do not operate a summer exhaust fan. Close fireplace dampers.
- 4 - Follow the lighting instructions. Place the appliance being inspected in operation. Adjust thermostat so appliance will operate continuously.
- 5 - Test for spillage at the draft hood relief opening after 5 minutes of main burner operation. Use match or candle flame, or smoke from a cigarette or cigar.
- 6 - After it has been determined that each appliance remaining connected to the common venting system properly vents when tested as outlined above, return doors, windows, exhaust fans, fireplace dampers and any other gas-burning appliance to their previous condition of use.
- 7 - If improper venting is observed during any of the tests, the common venting system must be corrected. The common venting system should be resized to approach the minimum size as determined by using the appropriate tables in appendix G in the current standards of the National Fuel Gas Code in the U.S.A. or category 1 in the Natural Gas and Propane Installation Code in Canada.

GHR32 Intake and Exhaust Piping Considerations

If the GHR32 venting system must be altered or repaired, use the following as a guide. Intake and exhaust pipes may be routed either horizontally through an outside wall or vertically through the roof. In attic or closet installations, vertical termination through the roof is preferred. Figures 42 through 45 show typical terminations.

- 1 - Use only recommended piping materials for both intake and exhaust piping.
- 2 - Secure permanent joints gas tight using approved cement.
- 3 - Piping diameters should be determined according to length of pipe run. See table 31. Locate intake piping upwind (prevailing wind) from exhaust piping. To avoid recirculation of exhaust gas on roof terminations, end of exhaust pipe must be higher than intake pipe.

Exhaust and intake exits must be in same pressure zone. Do not exit one through the roof and one through the side. Also, do not exit the intake on one side and the exhaust on another side of the house or structure.

- 4 - Intake and exhaust pipes should be placed as close together as possible at termination end (refer to illustrations). Maximum separation is 3" (76mm) on roof terminations and 6" (152mm) on side wall terminations.

NOTE-If winter design temperature is below 32° F (0° C), exhaust piping must be insulated with 1/2" (13mm) Armaflex or equivalent when run through unheated space. Do not leave any surface area of exhaust pipe open to outside air; exterior exhaust pipe must be insulated with 1/2" (13mm) Armaflex or equivalent. In extreme cold climate areas, 3/4" (19mm) Armaflex or equivalent is recommended. Insulation on outside runs of exhaust pipe must be painted or wrapped to protect insulation from deterioration.

- 5 - Exhaust piping must terminate straight out or up as shown. On roof terminations, the intake piping should terminate straight down using two 90° elbows (See figure 42). In rooftop applications, a 2" X 1-1/2" (51mm X 38mm) reducer for 2" (51mm) venting, 3" x 2" (76mm X 51mm) reducer for 3" (76mm) venting must be used on exhaust piping at the point where it exits the structure to improve the velocity of exhaust and force flue products away from intake piping.

NOTE-Care must be taken to avoid recirculation of exhaust back into intake pipe.

- 6 - On side wall exits, exhaust piping should extend a maximum of 12" (395mm) beyond the outside wall. Intake piping should be as short as possible. See figure 44.
- 7 - Minimum separation distance between the end of the exhaust pipe and the end of the intake pipe is 8" (203mm).
- 8 - If intake and exhaust piping must be run up a side wall to position above snow accumulation or other obstructions, refer to figure 45 for proper piping method. Piping must be supported every 3 ft. (.91m) as shown in figure 41 and must be insulated. When exhaust and intake piping must run up an outside wall, the exhaust piping is reduced accordingly after the final elbow.
- 9 - Position termination ends so they are free from any obstructions and above snow accumulation level (where applicable). Termination ends must be a minimum of 12" (305mm) above grade level. Do not point into window wells, stairwells, alcoves, courtyard areas or other recessed areas. Do not position termination ends directly below roof eaves.
- 10- Suspend piping using hangers at a minimum of every 5 feet (1.52m) for schedule 40 PVC and every 3 feet (.91m) for ABS-DWV, PVC-DWV, SDR-21 PVC, and SDR-26 PVC piping. A suitable hanger can be fabricated by using metal or plastic strapping or a large wire tie. See figure 41.

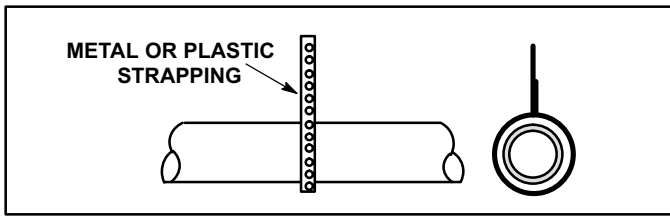

FIGURE 41

- 11- In areas where piping penetrates joists or interior walls, hole must be large enough to allow clearance on all sides of pipe through center of hole using support straps.
- 12- Isolate piping at the point where it exits the outside wall or roof.
- 13- Unit should not be installed in areas normally subject to freezing temperatures.
- 14- When furnace is installed in a residence where unit is shut down for an extended period of time, such as a vacation home, make provisions for draining exhaust tee, cold end header collector box, condensate collection trap and lines.

Intake Piping Requirements

Piping must be routed to outside of structure.

⚠ IMPORTANT

Combustion air intake inlet and exhaust outlet should not be located within 6 ft. (1.8m) of dryer vent or combustion air inlet or outlet of another appliance. Piping should not exit less than 3 ft. (.91m) from opening into another building.

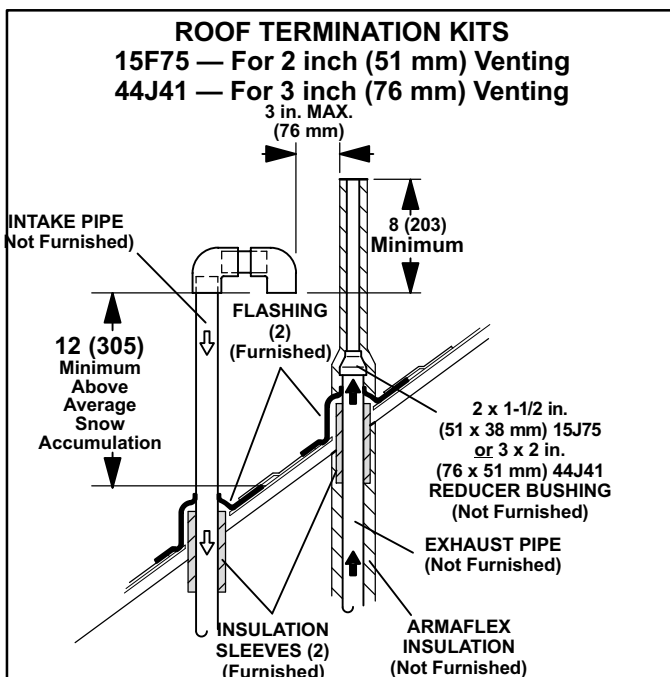
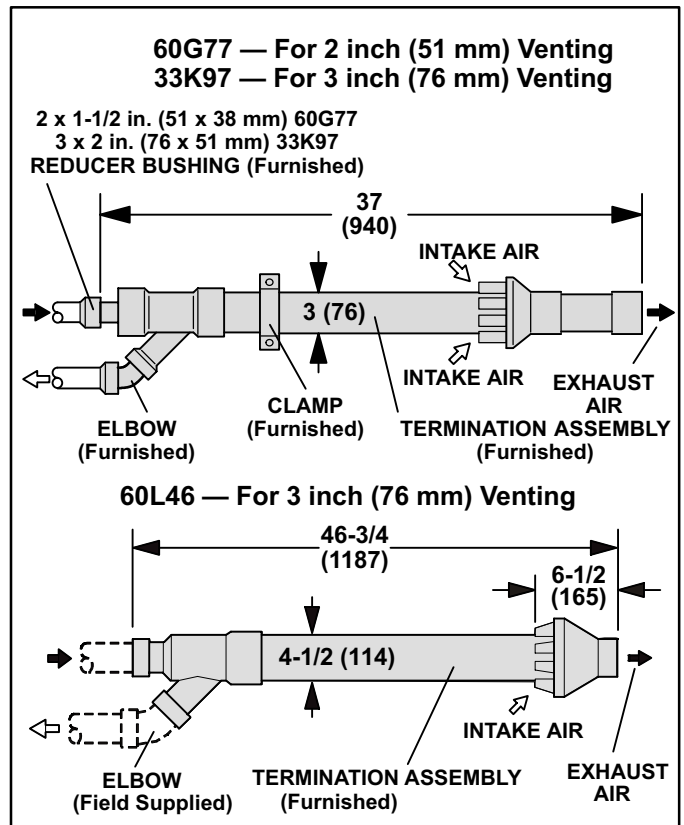
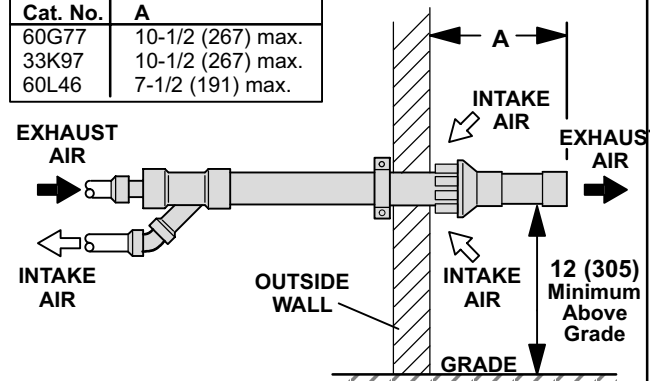

FIGURE 42



CONCENTRIC WALL TERMINATION APPLICATIONS

Cat. No.	A
60G77	10-1/2 (267) max.
33K97	10-1/2 (267) max.
60L46	7-1/2 (191) max.



CONCENTRIC ROOF TERMINATION APPLICATIONS

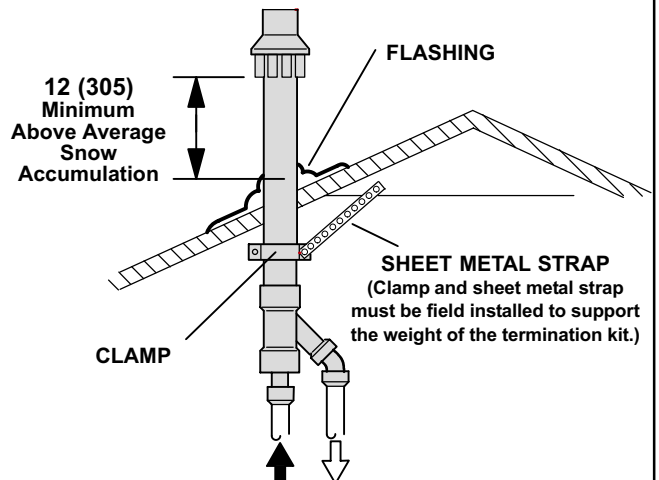

FIGURE 43

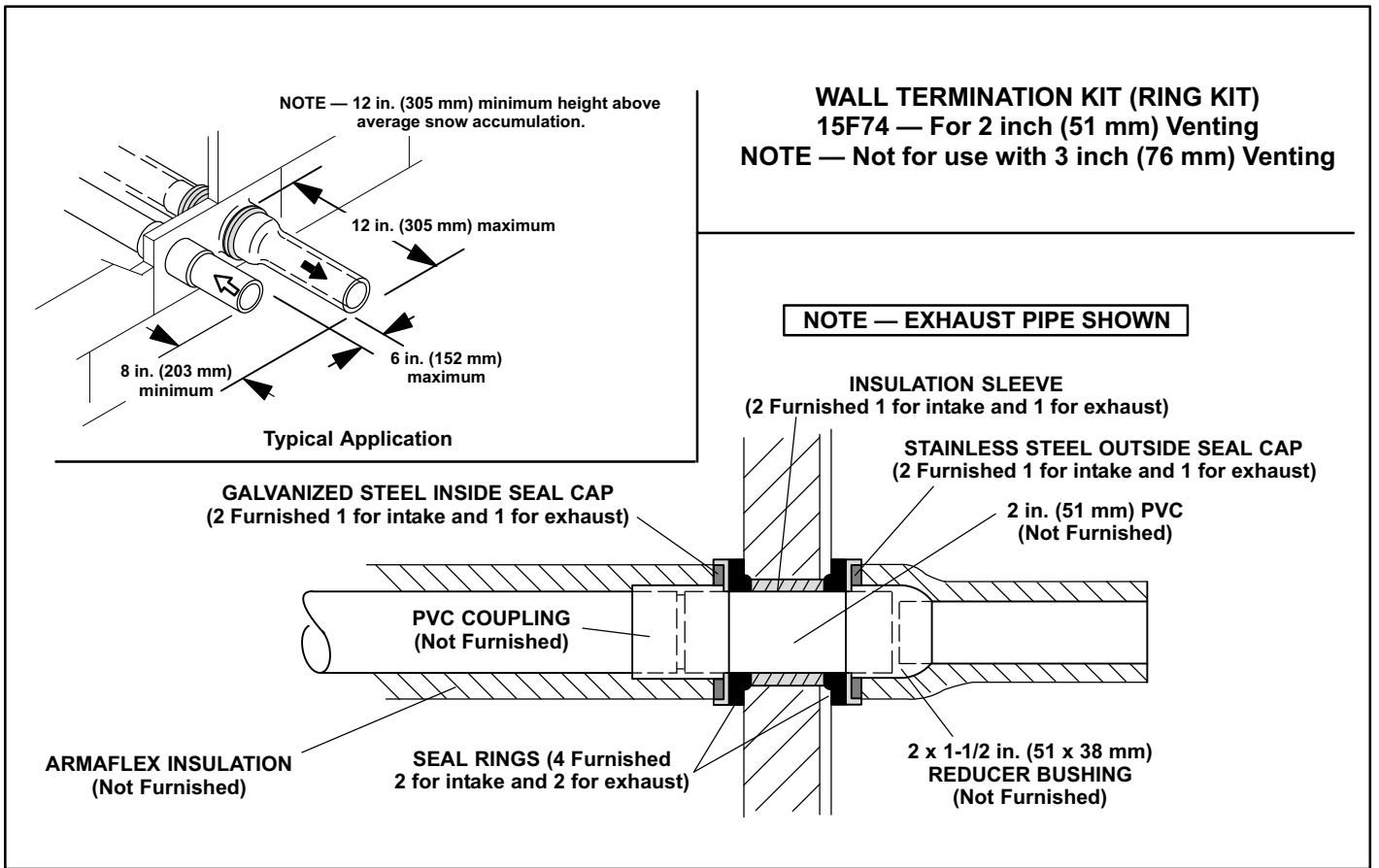

FIGURE 44

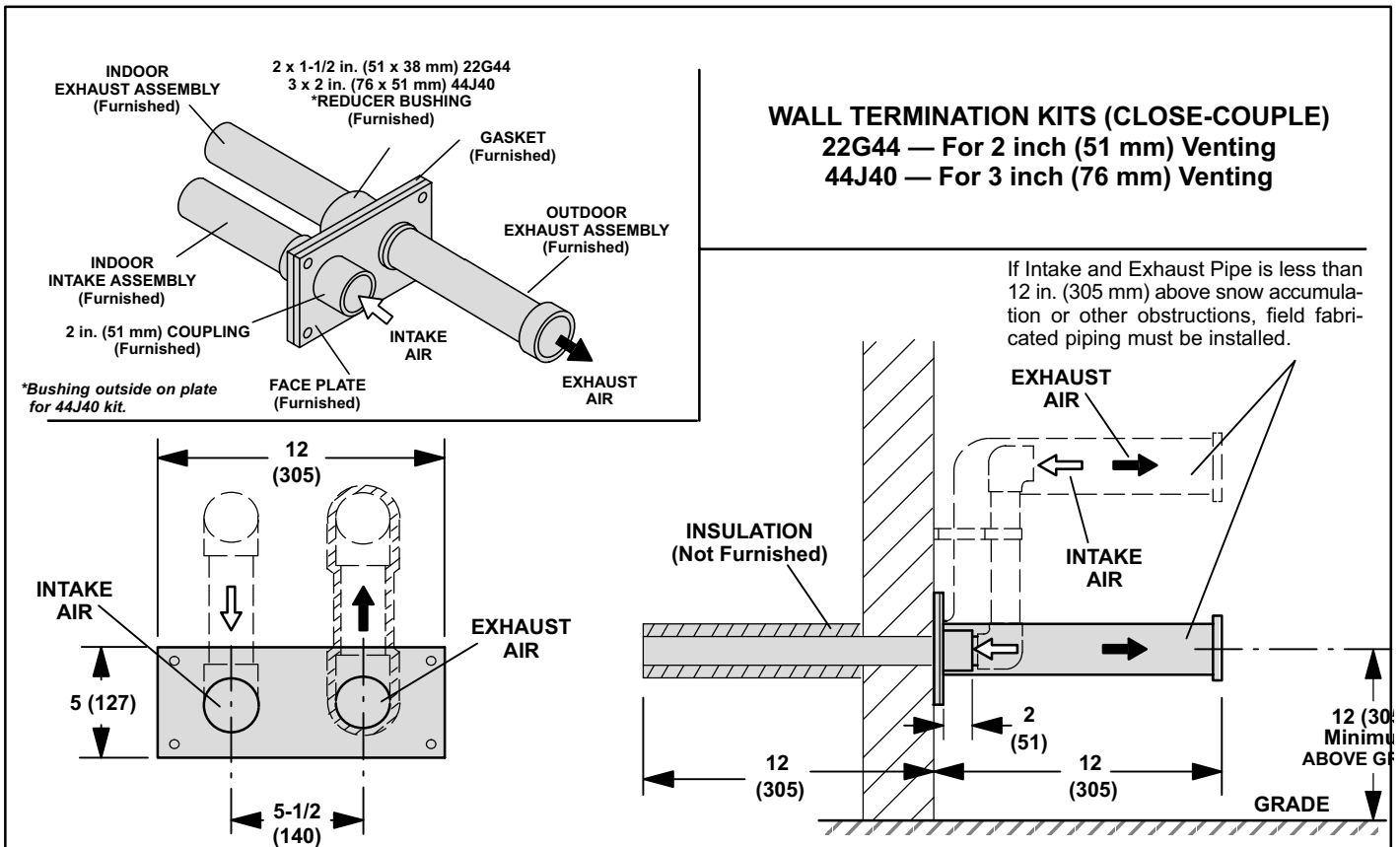

FIGURE 45

TABLE 31

VENTING REQUIREMENTS				
Model No.	GHR32-50	GHR32-75	GHR32-100	① GHR32-120
Vent Pipe Minimum Equivalent Length with Accelerator - Exhaust pipe should terminate with an accelerator. See Termination Kits, below.	② 20 ft. (6.1 m)	② 20 ft. (6.1 m)	③ 15 ft. (4.6 m)	④ 15 ft. (4.6 m)
Maximum Equivalent Vent Length Maximum length is for one individual run, either intake or exhaust.	feet (m)	Minimum Vent Pipe Diameter Required		
	15 (4.6)	Not Recommended		2 in. (51 mm)
	20 (6.1)	2 in. (51 mm)	2 in. (51 mm)	⑤ 3 in. (76 mm)
	25 (7.6)			
	30 (9.1)			
	35 (10.7)			
	40 (12.2)			
	45 (13.7)			
	50 (15.2)	3 in. (76 mm)	3 in. (76 mm)	Not Available
	55 (16.8)			
	60 (18.3)			
	70 (21.3)			
80 (24.4)				
90 (27.4)				
100 (30.5)	3 in. (76 mm)	3 in. (76 mm)	Not Available	

VENT/INTAKE AIR TERMINATION KIT USAGE								
Termination Kits	Kits for 2 in. (51 mm) Venting	Cat. No.		Acceptable	Acceptable	Acceptable	Not Available	
		NOTE - Intake and Exhaust pipes must be the same diameter.	NOTE - Exhaust pipe must be terminated with an accelerator; 1-1/2 in. (38.1 mm) diameter pipe, 12 in. (305 mm) in length.					Roof Kit (15F75)
Wall Ring Kit (15F74)								
⑤ Closed Couple Wall Kit (22G44)					⑥ Acceptable			
Concentric Roof/Wall Kit (60G77)					Not Available			
NOTE - Exhaust pipe must be terminated with an accelerator; 2 in. (51 mm) diameter pipe, 12 in. (305 mm) in length.	Kits for 3 in. (76 mm) Venting		⑤ Closed Couple Wall Kit (30G28)		Acceptable	Acceptable	Not Available	Not Available
			⑦ Closed Couple Wall Kit with extension riser (30G79)					
			Cat. No.					
			Concentric Roof/Wall Kit (60L46)		Not Available			Acceptable
			Vent/Intake Air Roof Kit (44J41)					Acceptable
			⑤ Closed Couple Wall Kit (44J40)	Acceptable	Acceptable	Acceptable		Acceptable
Concentric Roof/Wall Kit (33K97)					⑧ Acceptable			

① 2 in. (51 mm) pipe may be used to adapt terminations and intake/exhaust furnace connections. The TOTAL of 2 in. (51 mm) pipe that can be used CANNOT exceed 3 feet (1 m).

Equivalent Vent Lengths:

- ② 10 ft. (3 m) and two 90° elbows of 2 in. (51 mm) pipe equals 20 ft. (6.1 m).
- ③ 5 ft. (1.5 m) and two 90° elbows of 2 in. (51 mm) pipe equals 15 ft. (4.6 m).
- ④ 5 ft. (1.5 m) and two 90° elbows of 3 in. (76 mm) pipe equals 15 ft. (4.6 m). One 90° elbow equals 5 feet (1.5 m) of straight vent pipe. One 45° elbow equals 2.5 feet (.75 m) of straight vent pipe.

⑤ When additional/field supplied venting is used to clear average snow accumulation, the additional length of pipe and elbows must be figured into the Maximum Equivalent Vent Length/Minimum Vent Pipe Diameter Requirements.

⑥ 90° intake elbow CANNOT be used in this application.

⑦ 12 feet (3.6 m) of additional vent must be figured into the Maximum Equivalent Vent Length/Minimum Vent Pipe Diameter Requirements if this kit is used.

⑧ Only used with minimum vent length.

Exhaust Piping Requirements

This unit is designed for left or right air exhaust piping for the down-flow configuration. In horizontal applications, flue piping must exit the top side of the unit.

All horizontal runs of exhaust pipe must slope toward unit. A minimum of 1/4" (6mm) drop for every 12" (305mm) of horizontal run is mandatory for drainage. Horizontal runs of exhaust piping must be supported every 5 ft. (1.5m) [3 ft. (0.9m) for ABS and SDR] using hangers.

NOTE-Exhaust piping must be installed on the same side as the condensate trap.

NOTE-Exhaust piping should be checked carefully to make sure there are no sags or low spots.

⚠ CAUTION

Do not discharge exhaust into an existing stack or stack that also serves another gas appliance. If vertical discharge through an existing unused stack is required, insert PVC pipe inside the stack until the end is above the top or outlet end of the metal stack.

⚠ CAUTION

The exhaust vent pipe operates under positive pressure and must be completely sealed to prevent leakage of combustion products into the living space.

Condensate Piping Requirements

The GHR32 unit is designed for either left or right condensate plumbing in the down-flow configuration. In the horizontal position, trap should extend below unit; provide for a 3-3/4" (92mm) service clearance. Condensate drain line should be routed only within the conditioned space to avoid freezing of condensate and blockage of drain line. An electric heat cable should be used where condensate piping is exposed to unconditioned areas. If condensate piping needs to be relocated to another position or removed for service, use the following procedure to reinstall.

⚠ CAUTION

Do not use copper tubing or existing copper condensate lines for drain line.

- 1 - Determine the side the condensate trap is to be installed. Remove temporary plugs from condensate collar on which the condensate trap is to be installed.

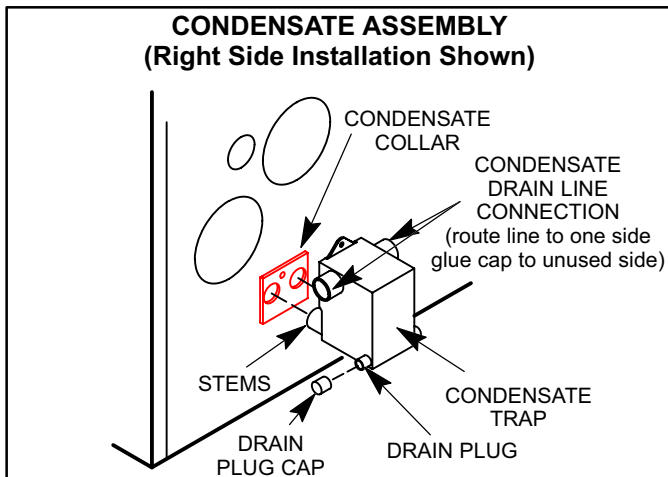

FIGURE 46

⚠ CAUTION

Condensate trap must be installed on the same side as exhaust piping in downflow applications and on bottom of unit in horizontal applications.

- 2 - Apply glue to condensate trap stems and insert trap into holes provided in condensate collar. Make sure condensate trap is completely sealed to avoid any leaks. Use the provided 1/2" screw to secure the top of the condensate trap to the side of the unit. See figure 46.
- 3 - For downflow applications only, remove plugs from the unused condensate collar on the opposite side of the unit. Apply glue to the plugs and place them back into the condensate collar.
- 4 - Glue the drain line (field provided) to the trap. Route drain line to an open drain. Glue 1" (25mm) cap (provided on trap) on unused condensate drain line connection.

- 5 - Install a tee and vent pipe in the drain line near the trap. Top of vent pipe should be 7" (178mm) above drain level on trap.
- 6 - Condensate line must be sloped downward away from trap (a minimum of 1/4" [6mm] drop for each 12" [305mm] of horizontal line) to drain. If drain level is above condensate trap, condensate pump must be used in condensate line.

III-START-UP

A-Preliminary and Seasonal Checks

- 1 - Inspect electrical wiring, both field and factory installed for loose connections. Tighten as required.
- 2 - Check voltage at disconnect switch. Voltage must be within range listed on the nameplate. If not, consult the power company and have voltage condition corrected before starting unit.
- 3 - Inspect condition of condensate traps and drain assembly. Disassemble and clean seasonally.

B-Heating Start-Up

FOR YOUR SAFETY READ BEFORE LIGHTING

⚠ WARNING

Do not use this furnace if any part has been underwater. Inspect the furnace and replace any part of the control system and any gas control which has been under water.

⚠ WARNING

If overheating occurs or if gas supply fails to shut off, shut off the manual gas valve to the appliance before shutting off electrical supply.

⚠ CAUTION

Before attempting to perform any service or maintenance, turn the electrical power to unit OFF at disconnect switch.

BEFORE LIGHTING smell all around the appliance area for gas. Be sure to smell next to the floor because some gas is heavier than air and will settle on the floor.

Use only your hand to push in or turn the gas control knob. Never use tools. If the knob will not push in or turn by hand, do not force. Force or attempted repair may result in a fire or explosion.

GHR32 units are equipped with a hot surface ignition system. Do not attempt to manually light burners on these furnaces. Each time thermostat calls for heat, the burners will be automatically lit.

How To Operate Gas Valve

! WARNING

If you do not follow these instructions exactly, a fire or explosion may result causing property damage, personal injury or loss of life.

- 1 - **STOP!** Read the safety information at the beginning of this section.
- 2 - Set thermostat to lowest setting.
- 3 - Turn off all electrical power to furnace.
- 4 - This appliance is equipped with an ignition device which automatically lights the burner. Do **not** try to light the burner by hand.
- 5 - Remove unit access panel.
- 6 - Natural valve, move lever to **OFF**. Propane valve, turn knob to **OFF**. Do not force.
- 7 - Wait five (5) minutes to clear out any gas. If you then smell gas, **STOP!** Immediately call your gas supplier from a neighbor's phone. Follow the gas supplier's instructions. If you do not smell gas go to next step.
- 8 - Natural valve, move lever to **ON**. Propane valve, turn knob to **ON**. Do not force.
- 9 - Replace access panel.
- 10- Turn on all electrical power to unit.
- 11- Set thermostat to desired setting.
- 12- If the appliance will not operate, follow the instructions "To Turn Off Gas To Unit" and call your service technician or gas supplier.

Turning Off Gas To Unit

- 1 - Set thermostat to lowest setting.
- 2 - Turn off all electrical power to unit if service is to be performed.
- 3 - Remove access panel.
- 4 - Natural valve, move lever to **OFF**. Propane valve, turn knob to **OFF**. Do not force.
- 5 - Replace access panel.

NOTE-On initial start-ups and when condensate trap is dry, unit may turn itself off and on to allow condensate trap to fill. This is normal operation.

C-Safety or Emergency Shutdown

Turn off unit power. Close manual and main gas valves.

D-Extended Period Shutdown

Turn off thermostat or set to "UNOCCUPIED" mode. Close all gas valves (both internal and external to unit) to guarantee no gas leak into combustion chamber. Turn off power to unit. All access panels, covers and vent caps must be in place and secured.

Refer to "Maintenance" section of this manual for instructions on how to prepare condensate assembly for extended period shutdown.

IV-HEATING SYSTEM SERVICE CHECKS

A-A.G.A./C.G.A. Certification

All units are A.G.A. and C.G.A. design certified without modifications. Refer to the GHR32 Operation and Installation Instruction Manual Information.

B-Gas Piping

Gas supply piping should not allow more than 0.5"W.C. drop in pressure between gas meter and unit. Supply gas pipe must not be smaller than unit gas connection.

Compounds used on gas piping threaded joints should be resistant to action of liquefied petroleum gases.

C-Testing Gas Piping

When pressure testing gas lines, the gas valve must be disconnected and isolated. Gas valves can be damaged if subjected to more than 0.5psig (14" W.C.). See figure 47. If the pressure is equal to or less than 0.5psig (14"W.C.), use the manual shut-off valve before pressure testing to isolate furnace from gas supply.

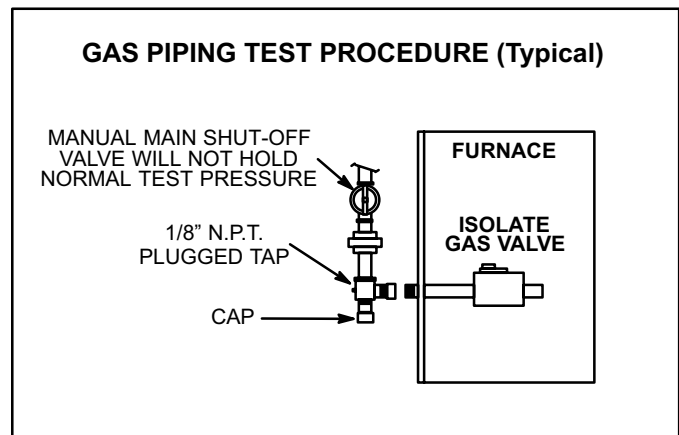

FIGURE 47

! IMPORTANT

In case emergency shutdown is required, turn off the main shut-off valve and disconnect the main power to unit. These controls should be properly labeled by the installer.

When checking piping connections for gas leaks, use preferred means. Kitchen detergents can cause harmful corrosion on various metals used in gas piping. Use of a specialty Gas Leak Detector is strongly recommended. It is available through Lennox under part number 31B2001. Do not use matches, candles, flame or any other source of ignition to check for gas leaks.

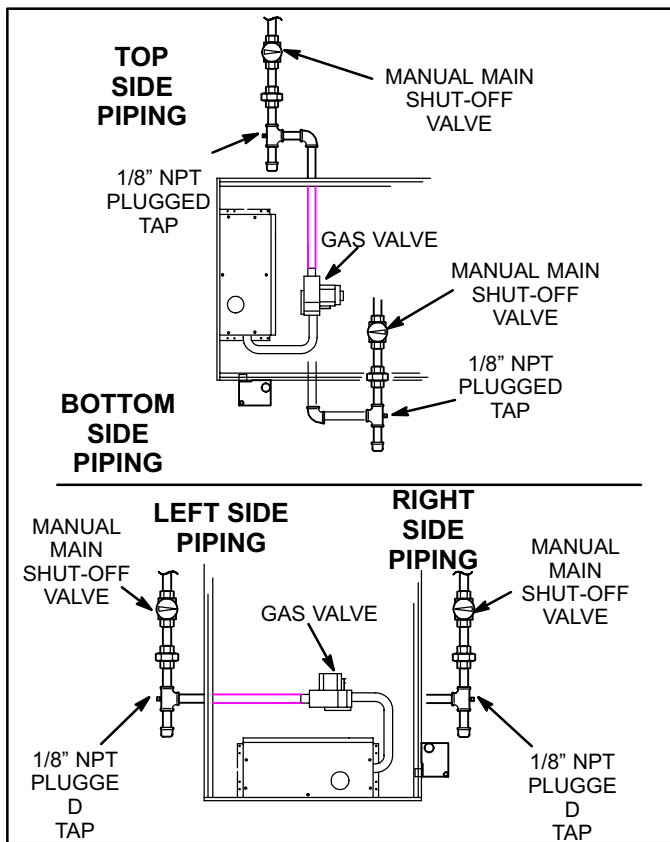

FIGURE 48

D-Testing Gas Supply Pressure

When testing supply gas pressure, connect test gauge to inlet pressure tap (field provided). See figure 48. Check gas line pressure with unit firing at maximum rate. Low pressure may result in erratic operation or underfire. High pressure can result in permanent damage to gas valve or overfire. For natural gas units, operating pressure at unit gas connection must be a minimum of 4.5" W.C. (1.12kPa). For L.P. gas units, operating pressure at unit gas connection must be a minimum of 11.0" W.C. (2.74kPa). For both natural and L.P. gas units, operating pressure must not exceed 13" W.C. (3.23 kPa).

On multiple unit installations, each unit should be checked separately, with and without the other units operating. Supply pressure minimum and maximum must be the same as listed in previous paragraph.

E-Check Manifold Pressure

Manifold *Operating* Pressure is the manifold pressure measured during normal operation (sensing burner box pressure). Manifold *Absolute* Pressure is manifold pressure measured when the gas valve regulator is operating at factory preset level (sensing atmospheric pressure).

After line pressure has been checked and adjusted, check manifold absolute pressure. Move pressure gauge to outlet pressure tap located on unit gas valve (GV1). Checks of manifold absolute pressure are made as verification of proper regulator adjustment.

Manifold operating pressure for the GHR32 can be measured at any time the gas valve is open and is supplying

gas to the unit. Normal manifold operating pressure for natural gas units is 2.5 to 3.5" W.C. (621 to 870 Pa). See figure 29. For LP/propane gas the correct manifold operating pressure is 9.0 to 10.0" W.C. (2.24 to 2.49 Pa). See figure 30.

! IMPORTANT

For safety, connect a shut-off valve between the manometer and the gas tap to permit shut off of gas pressure to the manometer.

TABLE 32
GAS VALVE REGULATION*

Unit (Fuel)	Absolute Pressure (outlet) in. W.C.
Natural	3.5
L.P.	10.0

The gas valve is factory set and should not require adjustment. See table 32. Also, gas valve regulation varies with burner box pressure (figures 29 and 30).

*Manifold Absolute Pressure Measurement and Adjustment

- 1 - Connect test gauge to outlet tap on gas valve.
- 2 - Disconnect pressure sensing hose from gas valve and plug hose by covering opening with tape or equivalent. Leave hose barb on valve open to atmosphere.
- 3 - Start unit and allow 5 minutes for unit to reach steady state.
- 4 - While waiting for the unit to stabilize, notice the flame. Flame should be stable and should not lift from burner. Natural gas should burn blue. L.P. gas should burn mostly blue with some orange streaks.
- 5 - After allowing unit to stabilize for 5 minutes, record manifold pressure and compare to values given in table 32. If values are different, adjust to table 32.

! IMPORTANT

For safety, shut unit off and remove manometer as soon as an accurate reading has been obtained. Take care to replace pressure tap plug.

NOTE-During this test procedure, the unit will be overfiring:

- Operate unit only long enough to obtain accurate reading to prevent overheating heat exchanger.
 - Attempts to clock gas valve during this procedure will be inaccurate. Measure gas flow rate only during normal unit operation.
- 6 - When test is complete remove obstruction from hose and return hose to gas valve barb.

F- Proper Gas Flow

Furnace should operate at least 5 minutes before checking gas flow. Determine time in seconds for **two** revolutions of gas through the meter. (Two revolutions assures a more accurate time.) **Divide by two** and compare to time in table 33 below. Adjust manifold on gas valve to match time needed.

NOTE-To obtain accurate reading, shutoff all other gas appliances connected to meter.

TABLE 33

GAS METER CLOCKING CHART				
GHR32 Unit	Seconds for One Revolution			
	Natural		LP	
	1 cu ft Dial	2 cu ft Dial	1 cu ft Dial	2 cu ft DIAL
-50	72	144	180	360
-75	48	96	120	240
-100	36	72	90	180
-120	30	60	75	150
Natural-1000 btu/cu ft			LP-2500 btu/cu ft	

G-Flame Signal

A microamp DC meter is needed to check the flame signal on the SureLight control. Use a flame signal transducer (part number 78H5401) available from Lennox to measure the flame signal, if meter used will not read microamp signal.

Flame (microamp) signal is an electrical current which passes from the ignition control through the sensor electrode during unit operation. Current passes from the sensor through the flame to ground to complete a safety circuit.

To Measure Flame Signal:

- 1 - Set the volt meter to the DC voltage scale. Insert transducer into the VDC and common inputs. Observe correct polarities. Failure to do so results in negative (-) values.
- 2 - Turn off supply voltage to control.
- 3 - Disconnect flame sensor lead from terminal of ignition control.
- 4 - Connect (+) lead of transducer to ignition control sensor connection.
- 5 - Connect (-) lead of the transducer to sensor wire.
- 6 - Turn supply voltage on and close thermostat contacts to cycle system.
- 7 - When unit lights, read voltage on meter display. Remember 1 DC volt = 1 DC microamp.

TABLE 34

FLAME SIGNAL MICROAMPS		
Boards 18M34 46M99 18M99 49M59	Normal	≥0.23
	Low	0.17 to 0.22
	Drop Out	0.16
Boards 63K89 24L85 56L83 97L48	Normal	≥0.61
	Low	0.21 to 0.60
	Drop Out	0.20

H- Variable Speed Motor

To check out the VSM blower and blower control board, begin with the ICM2 motor and follow the procedures outlined in section IX-TROUBLESHOOTING. The ICM2 consists of a control module and motor. The control module can be replaced separately from the the motor if necessary. However, if the motor fails the motor/control module assembly will have to be replaced.

V-TYPICAL OPERATING CHARACTERISTICS

A-Blower Operation and Adjustment

NOTE- The following is a generalized procedure and does not apply to all thermostat controls.

- 1 - Blower operation is dependent on thermostat control system.
- 2 - Generally, blower operation is set at thermostat sub-base fan switch. With fan switch in ON position, blower operates continuously. With fan switch in AUTO position, blower cycles with demand.
- 3 - In all cases, blower and entire unit will be off when the system switch is in OFF position.

B-Temperature Rise

Temperature rise for GHR32 units depends on unit input, blower speed, blower horsepower and static pressure as marked on the unit rating plate. The blower speed must be set for unit operation within the range of "AIR TEMP. RISE °F" listed on the unit rating plate.

To Measure Temperature Rise:

- 1 - Place plenum thermometers in the supply and return air plenums. Locate supply air thermometer in the first horizontal run of the plenum where it will not pick up radiant heat from the heat exchanger.
- 2 - Set thermostat to highest setting.
- 3 - After plenum thermometers have reached their highest and steadiest readings, subtract the two readings. The difference should be in the range listed on the unit rating plate. If the temperature is too low, decrease blower speed. If temperature is too high, first check the firing rate. Provided the firing rate is acceptable, increase blower speed to reduce temperature. To change blower speed taps see the Blower Speed Taps section in this manual.

C-External Static Pressure

1 - Measure tap locations as shown in figure 49.

2 - Punch a 1/4" diameter hole in supply and return air plenums. Insert manometer hose flush with inside edge of hole or insulation. Seal around the hose with perma-gum. Connect the zero end of the manometer to the discharge (supply) side of the system. On ducted systems, connect the other end of manometer to the return duct as above. For systems with non-ducted returns, leave the other end of the manometer open to the atmosphere.

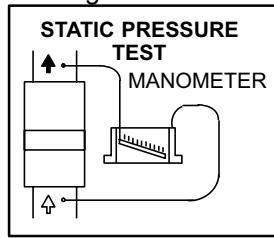

FIGURE 49

- 3 - With only the blower motor running and the evaporator coil dry, observe the manometer reading. Adjust blower motor speed to deliver the air desired according to the job requirements.
- 4 - Pressure drop must not exceed 0.5" W.C.
- 5 - Seal around the hole when the check is complete.

D-Blower Speed Taps GHR32Q Motors

Blower speed tap changes are made on the SureLight control board. See figure 9. Unused taps must be secured on dummy terminals "PARK M1" and or "PARK M2" on the SureLight board. The heating tap is connected to the "ACB HEAT" terminal and the cooling tap is connected to the "ACB COOL" terminal. The continuous blower tap is connected to the "ACB LOW" terminal.

To change existing heat tap, turn off power then switch out speed tap on "ACB HEAT" with tap connected to "PARK M1" or "PARK M2". See wiring diagrams for blower motor tap colors for each speed.

GHR32 BLOWER REMOVAL

To Remove Blower:

1. Turn off line voltage power. Unplug the following jack/plugs: J96/P96 power interface, J135/P135 secondary limit, J58/P58 control, J98/P98 CAB.
2. Remove screws (2) and remove control box cover. Disconnect thermostat wiring connections by removing low voltage terminal strip. Disconnect spark wire and grommet.
3. Loosen screws (2) and remove control box from unit. Holes are slotted so screws do not need to be removed.
4. Remove bolts (2) and remove blower from unit.

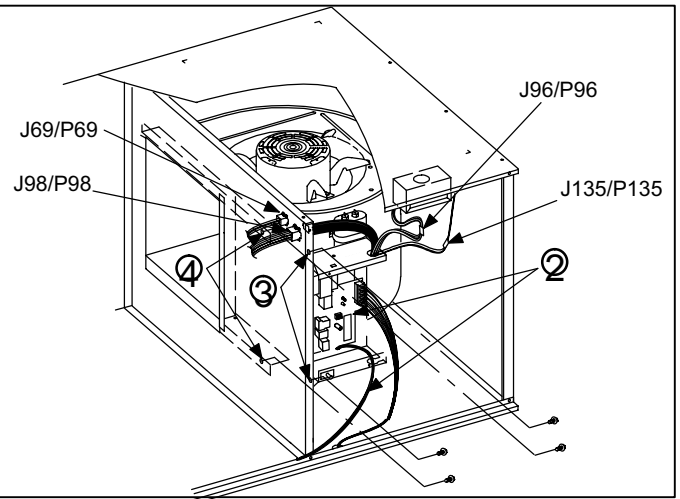

FIGURE 50

VI-MAINTENANCE

Retainers for factory supplied return air filter are shown in figure 51.

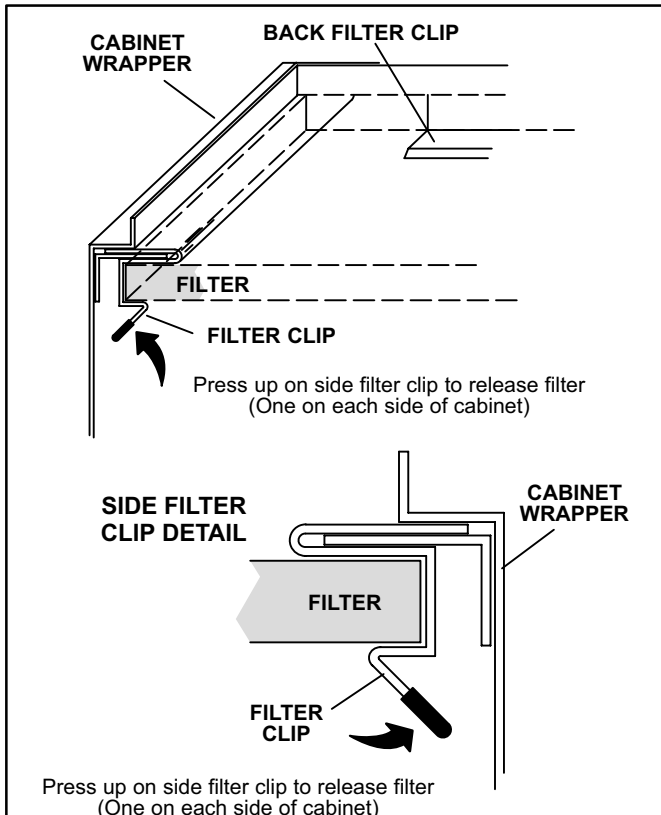

FIGURE 51

A-Filters

At the beginning of each heating season, the system should be checked as follows:

- 1 - Filters should be inspected monthly and must be cleaned or replaced when dirty to ensure proper furnace operation.
- 2 - Reusable foam filters used with the GHR32 can be washed with water and mild detergent. When dry, they should be sprayed with filter handicoater prior to reinstallation. Filter handicoater is RP Products coating no. 418 and is available as Lennox part no. P-8-5069.
- 3 - If replacement is necessary, order Lennox part no. 31J81 for 14 X 25 inch (356 X 635mm) filter for GHR32-50 and -75 units and P-8-7831 for 20 X 25 inch (508 X 635mm) filter for GHR32-100 and -120 units.

B-Cleaning Heat Exchanger and Burners

NOTE-Use papers or protective covering in front of furnace while cleaning furnace.

Cleaning the heat exchanger is not recommended; but, if it becomes necessary, follow the procedures outlined below and refer to figure 1 for parts arrangement. Pay close attention to wire routing and plumbing connections.

If at all possible, the unit should be removed and placed on its back. Tools needed are: slotted screwdriver, extra long 1/4" nut driver, extra long 5/16" nut driver, and duck-bill pliers.

Heat Exchanger

- 1 - Turn off electrical and gas power supplies to furnace.
- 2 - Remove upper and lower furnace access panels.
- 3 - Remove 3/8" rubber cap from condensate drain plug and drain. Replace cap after draining.
- 4 - Disconnect and remove intake pipe from air intake fitting.
- 5 - Mark all gas valve wires and disconnect them from valve.
- 6 - Remove gas supply line connected to gas valve. Disconnect gas valve sensing hose from side of burner box. Remove burner box cover by removing six (four on some units) securing screws. Remove gas valve/manifold assembly.
- 7 - Detach burner box from vestibule panel by removing four securing screws. Take care to avoid damaging the glass fiber gasket.
- 8 - Mark and disconnect spark and sensor electric wires from the ignitor and flame sensor.
- 9 - Disconnect wires from flame roll-out switch. Remove wires from patch plates. Remove side plates on burner box holding sensor and spark electrode. Set burner burner box assembly aside.
NOTE- If burner cleaning is needed, do so at this time. Refer to burner cleaning procedure.
- 10 - Remove flexible exhaust tee by loosening three clamps.
- 11 - Disconnect drain line attached to condensate trap. Remove screws that secure both condensate collars to either side of the unit and remove collars. It may be necessary to cut the pipe to allow for removal of the condensate trap. Remove drain tubes from cold end header collector box.
- 12 - Disconnect condensate drain tubing from exhaust pipe. Remove screws that secure both flue collars into place. Remove flue collars. It may be necessary to cut the exiting exhaust pipe to allow for removal of the fittings.
- 13 - Disconnect 2-pin plug from combustion air blower. Remove combustion air blower from bracket by removing four securing screws. Remove ground wire from bundle.
- 14 - Remove combustion air blower bracket by removing two screws from collector box and two screws from vestibule panel.
- 15 - Disconnect combustion air pressure and condensate sensing hoses from cold end header collector box. Remove pressure hose from two blank stems on cold end header collector box.
- 16 - Mark and remove wires from pressure switch. Remove pressure switch/bracket assembly. Keep hoses attached to pressure switch. Remove pressure switch installation screws from both sides of the unit.
- 17 - Disconnect 9-pin and 3-pin plugs at blower deck. Remove both plugs from the heat exchanger side of the blower deck.
- 18 - Remove the primary limit from vestibule panel.

- 19- Remove two (2) screws from the front cabinet flange at the blower deck. Remove front screws from cabinet at blower deck on left and right sides. Cabinet sides must be slightly spread apart to clear heat exchanger passage.
NOTE-To protect insulation in horizontal applications, slide a piece of sheet metal between the coil section of the heat exchanger and the cabinet when removing and replacing heat exchanger. Remove indoor blower for horizontal installations. Remove sheet metal when complete.
- 20- Remove screws along vestibule sides and bottom which secure vestibule panel and heat exchanger assembly to cabinet.
- 21- With a pair of duck bills, carefully bend bottom flange straight. Use caution not to damage the cabinet. Remove heat exchanger.
- 22- Back wash heat exchanger with soapy water solution or steam. **If steam is used it must be below 275°F (135°C).**
- 23- Thoroughly rinse and drain the heat exchanger. Soap solution can be corrosive so take care that entire assembly is completely rinsed.
- 24- Re-install heat exchanger into cabinet (blower deck end first) making sure that the clamshells of the heat exchanger assembly are resting on the supports at the rear of the cabinet. This can be viewed by removing the indoor blower and examining through the blower opening.
- 25- Re-secure the supporting screws along the vestibule sides and bottom to the cabinet. Carefully bend bottom flange back to a 90 degree angle with a pair of duck bills. Once again, use caution not to damage the cabinet.
- 26- Re-install cabinet screws on sides and front flange at blower deck.
- 27- Re-install primary limit to vestibule panel.
- 28- Re-install 9-pin plug to blower deck and connect it to the 9-pin plug from below the blower deck. Re-install 3-pin plug to blower deck and connect it to the 3-pin plug from below the blower deck.
- 29- Re-install pressure switch/bracket assembly and replace pressure switch screws on both sides of unit from installed pressure switch. Reconnect wires to pressure switch.
- 30- Connect combustion air pressure and condensate sensing hoses from pressure switch to cold end header collector box. See figure 31 to confirm hose location.
- 31- Re-install the combustion air bracket.
- 32- Re-install the combustion air blower to bracket. Reconnect the 2-pin plug to the wire harness.
- 33- Replace flue collars with securing screws to either side of the unit. Reconnect exhaust piping and exhaust drain tubing.
- 34- Replace condensate collars with securing screws to either side of the unit. Reconnect drain line to condensate trap. Reconnect drain tubing from cold end header collector box. Reconnect condensate drain tubing from exhaust pipe.
- 35- Replace flexible exhaust tee to combustion air blower and exhaust pipes and secure with three clamps.
- 36- Align burner box gasket to securing holes closest to the end of the unit. Use a small piece of tape to secure gasket to vest panel. Make sure glass fiber gasket has not been damaged so it will provide a continuous seal between the burner box and the vestibule panel.
- 37- Move burner box assembly to vestibule area.
- 38- Reconnect flame roll-out switch wires. Re-install patch plates to side of burner box. Connect wires to patch plates.
- 39- Reconnect sensor and spark electrode or SureLight ignitor wires through provided openings in the burner plate.
- 40- Replace four screws to secure reassembled burner box assembly to vestibule panel. **Make sure burners line up in center of burner ports.**
- 41- Re-install gas valve manifold assembly. Replace burner box cover. Re-install gas supply line to gas valve. Attach gas valve pressure sensing hose to burner box.
- 42- Reconnect gas valve wires to gas valve.
- 43- Re-install intake vent pipe to rubber connector on intake fitting with hose clamp.
- 44- Replace both upper and lower access panels.
- 45- Refer to instruction on verifying gas and electrical connections when re-establishing supply.
- 46- Following lighting instructions, light and run unit for 5 minutes to ensure heat exchanger is clean, dry and operating safely.

Cleaning the Burner Assembly

- 1 - Turn off electrical and gas power supplies to furnace.
- 2 - Remove upper and lower furnace access panels.
- 3 - Disconnect and remove intake pipe from air intake fitting.
- 4 - Mark all gas valve wires and disconnect them from valve.
- 5 - Remove gas supply line connected to gas valve. Disconnect gas valve sensing hose from valve. Remove burner box cover (4 to 6 screws). Remove gas valve/manifold assembly.
- 6 - Loosen hose clamp holding the air intake pipe to the no-hub connector on the top of the burner box. Remove pipe from no-hub connector and set aside.
- 7 - Mark and disconnect spark or SureLight ignitor and sensor electrical wires from the ignitor and flame sensor.
- 8 - Detach burner box from vestibule panel by removing four securing screws. Take care to avoid damaging the glass fiber gasket.
- 9 - On GHR32-50 and -75 units, remove air intake fitting from burner box top.
- 10 - Remove burner box top from burner box assembly.
- 11 - Using 1/4" nut driver, remove two screws holding burners in place. Slide burner assembly out of burner box.
- 12 - Clean burner by running a vacuum with a soft brush attachment over face of burners. Visually inspect inside of burners and crossovers for any blockage caused by foreign matter. Remove any blockage.
- 13 - Re-install burner assembly so that protruding side (not cavity side) of metal buttons are toward the burner box top (intake side).
- 14 - Replace top and air intake piece to burner box.
- 15 - Reconnect sensor and spark electrode or SureLight ignitor wires.
- 16 - Align burner box gasket to securing holes closest to the end of the unit. Use a small piece of tape to secure gasket to vest panel. Make sure glass fiber gasket has not been damaged so it will provide a continuous seal between the burner box and the vestibule panel.
- 17 - Replace four screws to secure reassembled burner box assembly to vestibule panel. **Make sure burners line up in center of burner ports.**

- 18 - Re-install gas valve/manifold assembly. Re-install burner box cover. Reconnect gas valve sensing hose to side of burner box. Re-install gas supply line to gas valve.
- 19 - Reconnect gas valve wires to gas valve.
- 20 - Replace both upper and lower access panels.
- 21 - Refer to instruction on verifying gas and electrical connections when re-establishing supply.
- 22 - Following lighting instructions, light and run unit for 5 minutes to ensure heat exchanger is clean, dry and operating safely.

C-Supply Air Blower

- 1 - Check and clean blower wheel.
- 2 - Motors are prelubricated for extended life; no further lubrication is required.

D-Electrical

- 1 - Check all wiring for loose connections.
- 2 - Check circuit breaker located in unit control box.
- 3 - Check for correct voltage at unit (unit operating).
- 4 - Check amp-draw on blower motor.
Motor Nameplate _____ Actual _____
- 5 - Check to see that heat (if applicable) is operating.

E-Intake and Exhaust Lines

Check intake and exhaust lines and all connections for tightness and make sure there is no blockage. Also check condensate line for free flow during operation.

F-Insulation

Outdoor piping insulation should be inspected yearly for deterioration. If necessary, replace with same materials.

G-Winterizing and Condensate Trap Care

If the unit is to be shut down for an extended period of time and will be exposed to sub-freezing temperatures, the unit should be winterized by draining water from the condensate trap.

To drain condensate trap remove the 3/8" cap located on the bottom corner of the condensate trap (see figure 46). Periodically drain condensate trap to insure proper drainage and check for blockage.

GHR32Q -3 UNIT DIAGRAM

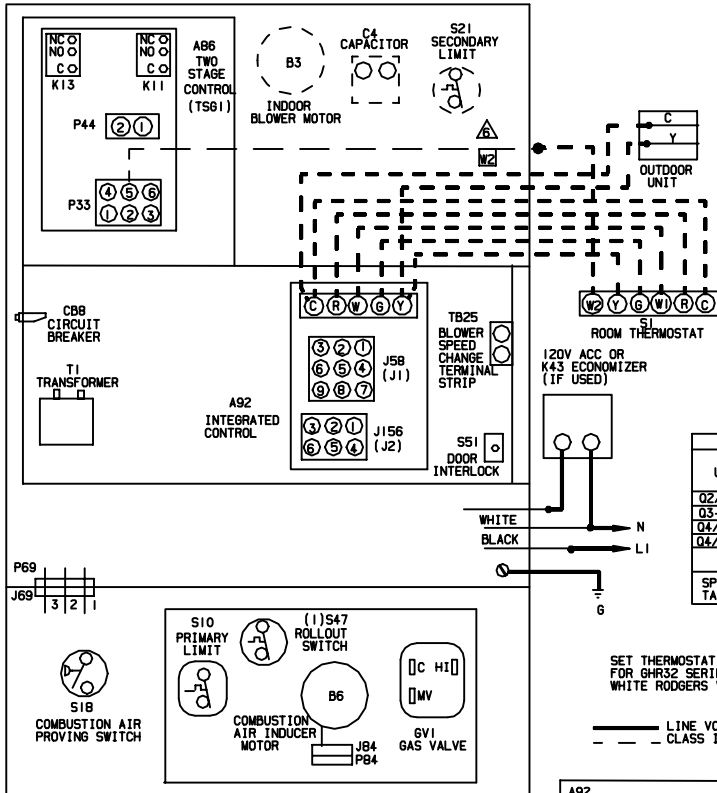

WARNING-
ELECTRIC SHOCK HAZARD CAN CAUSE INJURY OR DEATH. UNIT MUST BE GROUNDED IN ACCORDANCE WITH NATIONAL AND LOCAL CODES.

NOTE-
IF ANY WIRE IN THIS APPLIANCE IS REPLACED, IT MUST BE REPLACED WITH WIRE OF LIKE SIZE, RATING AND INSULATION THICKNESS.

⚠ M1 & M2 ARE UNPOWERED TERMINALS. ALL UNUSED MOTOR LEADS MUST BE PLACED ON EITHER M1 OR M2.

⚠ NOTE-W2 CONNECTION USED FOR TWO STAGE THERMOSTAT ONLY. TAPE OFF IF SINGLE STAGE THERMOSTAT IS USED.

JACKPLUG CHART	
J. P33	JACK/PLUG-CONTROL INTERFACE
J. P38	JACK/PLUG-MOTOR SPD CHANGE
J. P44	JACK/PLUG-TWO SPD CONTROL
J. P58	JACK/PLUG-BURNOUT CONTROL
J. P69	JACK/PLUG-BLOWER DECK
J. P84	JACK/PLUG-COMB. AIR BLOWER
J. P98	JACK/PLUG-BLOWER DECK
J. P156	JACK/PLUG-IGNITION
J. P159	JACK/PLUG-IGNITION

UNIT	FACTORY CONNECTED SPEED TAPS				MOTOR SPEEDS AVAILABLE
	COOL	HEAT	ACB LOW	M1 M2	
02/3-50	YELLOW	RED	---	BROWN	4
03-75	YELLOW	RED	---	BROWN	4
04/75-100	BLACK	YELLOW	RED	BROWN BLUE	5
04/5-120	BLACK	BLUE	RED	BROWN YELLOW	5
HI ← BLOWER SPEED SELECTION → LO					
SPEED TAPS	BLACK	BROWN	YELLOW	RED	4
	BLACK	BROWN	BLUE	YELLOW	5

SET THERMOSTAT HEAT ANTICIPATION FOR GHR32 SERIES UNITS AS FOLLOWS:
WHITE RODGERS VALVE... .5

— LINE VOLTAGE FIELD INSTALLED
- - - CLASS II VOLTAGE FIELD WIRING

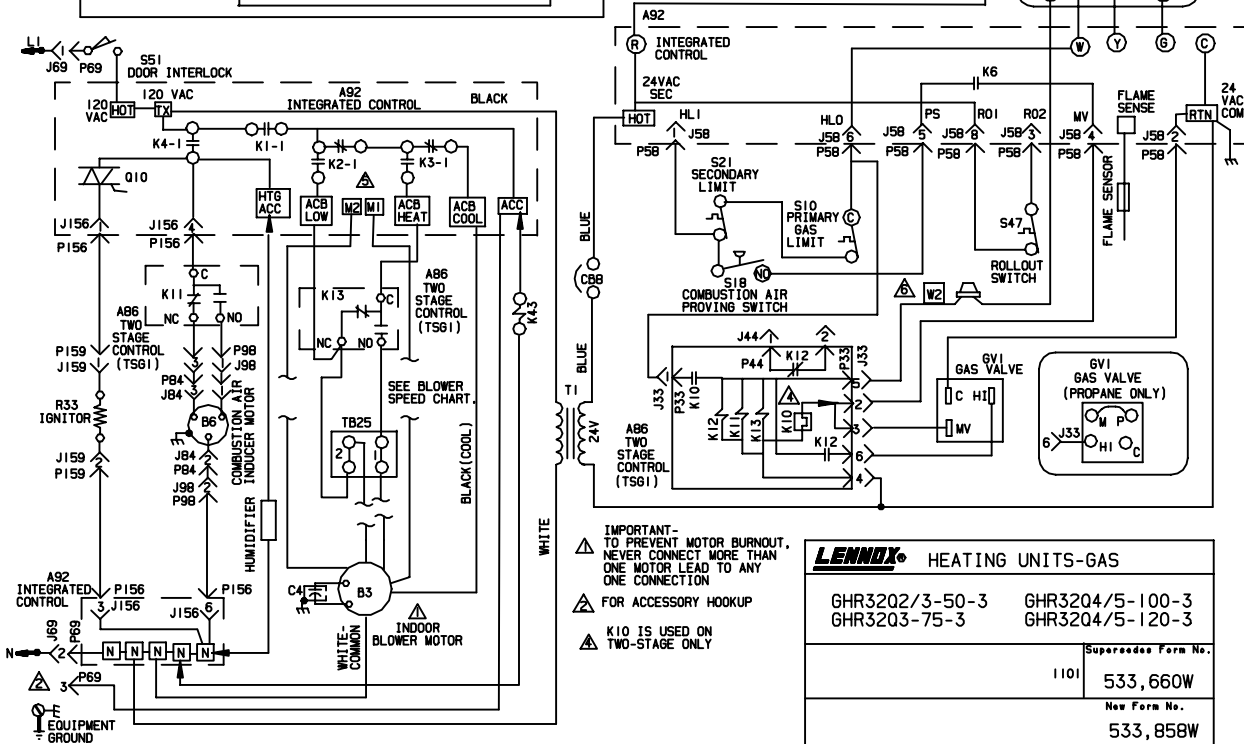
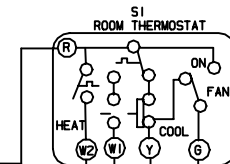

- ⚠ IMPORTANT - TO PREVENT MOTOR BURNOUT, NEVER CONNECT MORE THAN ONE MOTOR LEAD TO ANY ONE CONNECTION
- ⚠ FOR ACCESSORY HOOKUP
- ⚠ K10 IS USED ON TWO-STAGE ONLY

LENNOX® HEATING UNITS-GAS	
GHR32Q2/3-50-3	GHR32Q4/5-100-3
GHR32Q3-75-3	GHR32Q4/5-120-3
Supersedes Form No.	
1101 533,660W	
New Form No.	
533,858W	

← DENOTES OPTIONAL COMPONENTS

Sequence of Operation GHR32Q -1, -3 Units

Ignitor operation will vary between SureLight boards. Board 56L83 will energize ignitor for the first second of the 4 second ignition trial. Board 97L48 will energize ignitor during the entire ignition trial until flame is sensed.

- 1 - When there is a call for heat, W1 of the thermostat energizes W of the furnace control with 24VAC.
- 2 - SureLight control runs self-check for S10 primary limit switch normally closed contacts and S18 combustion air prove switch normally open contacts. Follow steps 4 through 8 per respective thermostat.

Single-stage Mode, Single-stage Thermostat

- 3 - SureLight control energizes combustion air inducer B6 on high speed. Combustion air inducer runs until S18 prove switch closes (switch will close within 2-1/2 minutes or control goes into Watchguard-Prove Switch mode). A 15-second pre-purge follows after S18 closes.
- 4 - SureLight control energizes ignitor. A 20-second warm-up period begins.
- 5 - Gas valve is energized on first stage heat (low). Gas valve opens for a 4-second trial for ignition.
- 6 - Flame is sensed, After 8 seconds from when gas valve opens, valve energizes on second stage (high heat).
- 7 - After 45-second delay, indoor blower B3 is energized on heating speed.

Two-stage Mode, Single-stage Thermostat

- 1 - SureLight control energizes combustion air inducer B6 on low speed. Combustion air inducer runs until combustion air proving switch S18 closes (switch will close within 2-1/2 minutes or control goes into Watchguard-Prove Switch mode). A 15-second pre-purge follows once S18 closes.
- 2 - SureLight control energizes ignitor. A 20-second warm-up period begins.
- 3 - Gas valve is energized on first stage. Gas valve opens for a 4-second trial for ignition. Signal is sent from control module to two-stage control board to begin W2 (second-stage) ON delay.
- 4 - Flame is sensed, gas valve remains open for the heat call.
- 5 - After 45-second delay, indoor blower B3 is energized on low speed.
- 6 - Second stage time on delay complete (8, 12, or 15 minutes). Combustion air inducer B6 switches to high speed, indoor blower B3 switches to heating speed and gas valve opens on high heat (second stage.)

Two-stage Mode, Two-stage Thermostat

- 1 - SureLight control energizes combustion air inducer B6 on low speed. Combustion air inducer runs until combustion air inducer switch S18 closes. Switch will close within 2-1/2 minutes or control goes into Watchguard-Proving Switch mode). A 15-second pre-purge follows once S18 closes.
- 2 - SureLight control energizes ignitor. A 20-second warm-up period begins.
- 3 - Gas valve is energized on first stage only. Gas valve opens for a 4-second trial for ignition.
- 4 - Flame is sensed, gas valve remains open for the heat call.
- 5 - After 45-second delay, indoor blower B3 is energized on low speed.
- 6 - Call for second stage heat comes from indoor thermostat (W2).

GHR32Q -5 & -6 UNIT DIAGRAM

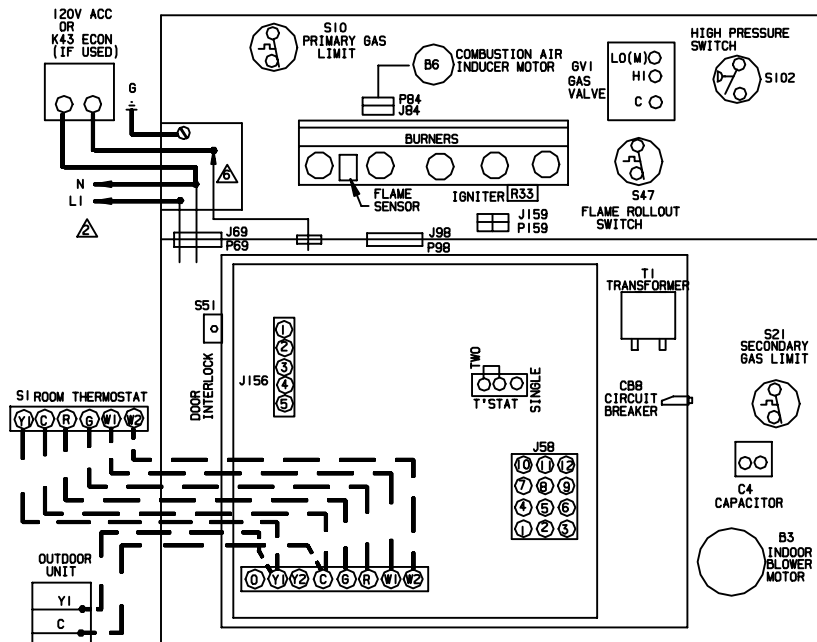

UNIT	BLOWER SPEED CHART				MOTOR SPEEDS AVAILABLE
	COOL	HI HEAT	LOW HEAT	PARK	
02/3-50	BROWN	YELLOW	---	RED	4
03-75	BROWN	YELLOW	---	RED	4
04/5-100	BLACK	YELLOW	RED	BLUE	5
04/5-120	BLACK	YELLOW	RED	BLUE	5

HI ← BLOWER SPEED SELECTION → LO

SPEED TAPS	BLACK	BROWN	YELLOW	RED	4	
	BLACK	BROWN	BLUE	YELLOW	RED	5

JACKPLUG CHART	
J.P33	JACK/PLUG-CONTROL INTERFACE
J.P34	JACK/PLUG-MOTOR SPD CHANGE
J.P44	JACK/PLUG-TWO SPD CONTROL
J.P58	JACK/PLUG-BURNER CONTROL
J.P69	JACK/PLUG-BLOWER DECK
J.P84	JACK/PLUG-ONB AIR BLOWER
J.P98	JACK/PLUG-BLOWER DECK
J.P158	JACK/PLUG-INDUCER
J.P159	JACK/PLUG-IGNITION

THERMOSTAT HEAT ANTICIPATION SETTING	
.65 AMPS	HONEYWELL VALVE
.50 AMPS	WHITE-RODGERS VALVE

WARNING- ELECTRIC SHOCK HAZARD, CAN CAUSE INJURY OR DEATH. UNIT MUST BE GROUNDED IN ACCORDANCE WITH NATIONAL AND LOCAL CODES.

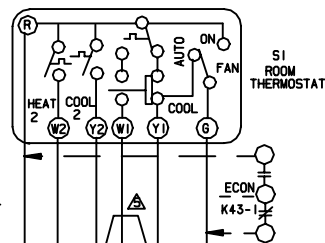

NOTE- IF ANY WIRE IN THIS APPLIANCE IS REPLACED, IT MUST BE REPLACED WITH WIRE OF LIKE SIZE, RATING AND INSULATION THICKNESS.

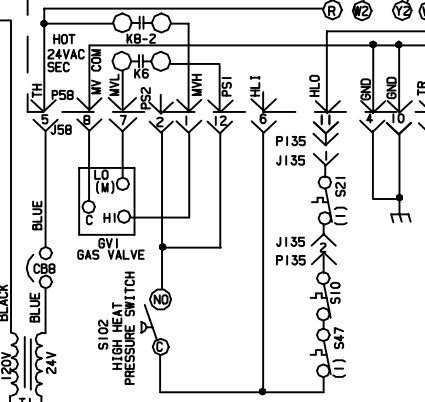
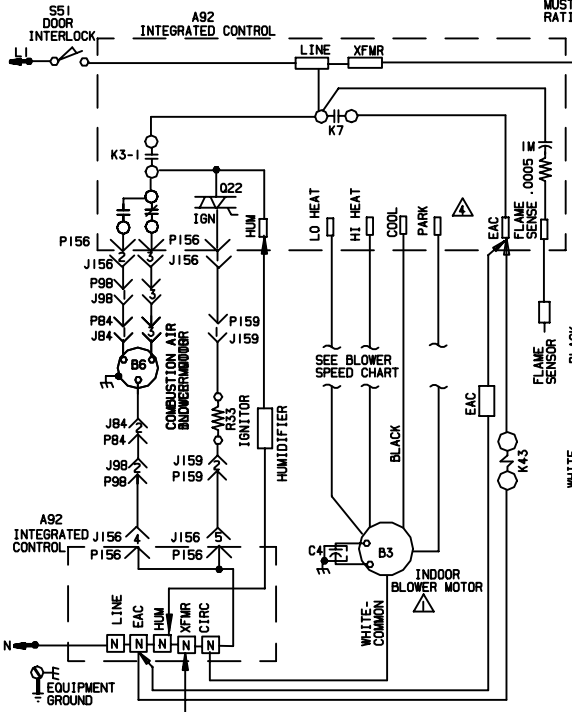

FIELD SUPPLIED ACC WIRE
 Y1 TO Y2 JUMPER FACTORY INSTALLED. LEAVE IN FOR ONE STAGE COOL THERMOSTAT. REMOVE JUMPER Y1 TO Y2 FOR TWO STAGE COOL THERMOSTAT.
 PARK TERMINAL IS AN UNPOWERED TERMINAL. ALL UNUSED MOTOR LEADS MUST BE WIRED TO THE PARK TERMINAL.

FACTORY DEFAULT IS FOR A 2 STAGE THERMOSTAT
 NOTE: FOR USE WITH COPPER CONDUCTORS ONLY
 IMPORTANT- TO PREVENT MOTOR BURNOUT, NEVER CONNECT MORE THAN ONE MOTOR LEAD TO ANY ONE CONNECTION

— LINE VOLTAGE FIELD INSTALLED
 - - - CLASS II VOLTAGE FIELD WIRING
 ← DENOTES OPTIONAL COMPONENTS

LENNOX HEATING UNITS-GAS	
GHR32Q2/3-50-5,6	GHR32Q4/5-100-5,6
GHR32Q3-75-5,6	GHR32Q4/5-120-5,6
Supersedes Form No. 1102	534,026W
New Form No.	534,304W

©2002 Lennox Industries Inc.

Li tho U.S.A.

Sequence of Operation. GHR32Q with SureLight Two Stage Control

Sequence depends on type thermostat used. Units are applicable for single stage or two stage thermostats. Both type thermostats are described below. Thermostat jumper E20 dictates which mode unit will operate in. See flow chart for more sequence detail.

SureLight Control Self Check

When there is a call for heat, the SureLight integrated control runs a self check. The control checks for S10 primary limit, S21 secondary limit (s) and S47 rollout switch normally closed contacts. The control also checks for S102 prove switch normally open contacts. Once self check is complete and all safety switches are operational, heat call can continue.

Two-Stage Thermostat, Two Stage Heat. Jumper E20 set at "TWO".

- 1- SureLight control energizes combustion air inducer B6 on low heat speed. Combustion air inducer runs until S102 closes (switch must close within 2 1/2 minutes or control goes into Watchguard Pressure Switch mode. A 15 second pre-purge follows once S102 closes.
- 2- SureLight control begins 20 second ignitor warm up period.
- 3- Gas valve opens on first stage for a 4 second trial for ignition. Ignitor stays energized during the trial or until flame sensed.
- 4- Flame is sensed, gas valve remains on first stage heat, ignitor de-energizes.
- 5- After 45 second delay, indoor blower B3 is energized on low heat speed.
The furnace will stay in this mode until first stage demand is satisfied OR a second stage heat demand is initiated.
- 6- Second stage heat demand initiated. A 30 second second stage recognition period begins.
- 7- The combustion air inducer ramps up to high heat speed.
- 8- B3 indoor blower ramps up to high heat speed.

Single-Stage Thermostat, Two Stage Heat. Jumper E20 set at "SINGLE"

- 1- SureLight control energizes combustion air inducer B6 on low heat speed. Combustion air inducer runs until S102 prove switch contacts close (switch must close within 2 1/2 minutes or control goes into Watchguard Pressure Switch mode. A 15 second pre-purge follows once S102 closes.
- 2- SureLight control begins 20 second ignitor warm up period.
- 3- Gas valve opens on first stage for a 4 second trial for ignition. Ignitor stays energized during the trial or until flame sensed.
- 4- Flame is sensed, gas valve remains on first stage heat, ignitor de-energizes.
- 5- After 45 second delay, indoor blower B3 is energized on low heat speed.
- 6- A 10 minute (factory set) or 15 minute (field set) second stage heat delay period begins.
- 7- The combustion air inducer ramps up to high heat speed.
- 8- B3 indoor blower ramps up to high heat speed.

GHR32V -1 UNIT DIAGRAM

LENOX HEATING UNITS-GAS	
GHR32V3-75-1	Supplement Part No.
GHR32V5-100-1	0300
GHR32CV5-100-1	533, 080W
	Net Part No.
	533, 080W
	LENEX U.S.A.

JACKPLUG CHART	
J.P20	JACK/PLUG-GAS
J.P33	JACK/PLUG-CONTROL INTERFACE
J.P38	JACK/PLUG-MOTOR SPD CHANGE
J.P44	JACK/PLUG-TWO-SPD CONTROL
J.P58	JACK/PLUG-BURNER CONTROL
J.P69	JACK/PLUG-BLOWER DECK
J.P84	JACK/PLUG-COMB. AIR BLOWER
J.P98	JACK/PLUG-BLOWER DECK
J.P156	JACK/PLUG-INDUCER
J.P159	JACK/PLUG-IGNITION

BLOWER SPEED CHART				
VSP2 FACTORY SPEED SETTINGS				
UNIT	HIGH	LOW	HEAT	ADJUST
V3-75	4	3	3	NORM
V5-100	4	2	1	NORM
V5-125	4	3	2	NORM

THERMOSTAT HEAT ANTICIPATION SETTING
 [.50 AMP WHITE-RODGERS VALVE]

WARNING-
 ELECTRIC SHOCK HAZARD CAN CAUSE INJURY
 OR DEATH. UNIT MUST BE GROUNDED IN ACCORDANCE
 WITH NATIONAL AND LOCAL CODES.

NOTE-
 IF ANY WIRE IN THIS APPLIANCE IS REPLACED, IT
 MUST BE REPLACED WITH WIRE OF LIKE SIZE,
 RATING AND INSULATION THICKNESS.

——— LINE VOLTAGE FIELD WIRING
 - - - CLASS II VOLTAGE FIELD WIRING

————— DENOTES OPTIONAL COMPONENTS

△ FOR ACCESSORY HOOKUP
 △ S12B USED ON
 632-75 UNIT ONLY.
 △ K10 IS USED ONLY
 ON W2 TIMED CIRCUIT.

△ JUMPER FROM DS TO Y1 IS FACTORY
 WIRED FOR SINGLE STAGE COOLING.
 △ W2 ON TERMINAL BOARD IS USED
 FOR TWO STAGE THERMOSTAT AND
 HARMONY. DO NOT JUMPER W2 TO W1
 ON TERMINAL BOARD WITH SINGLE
 STAGE THERMOSTAT.

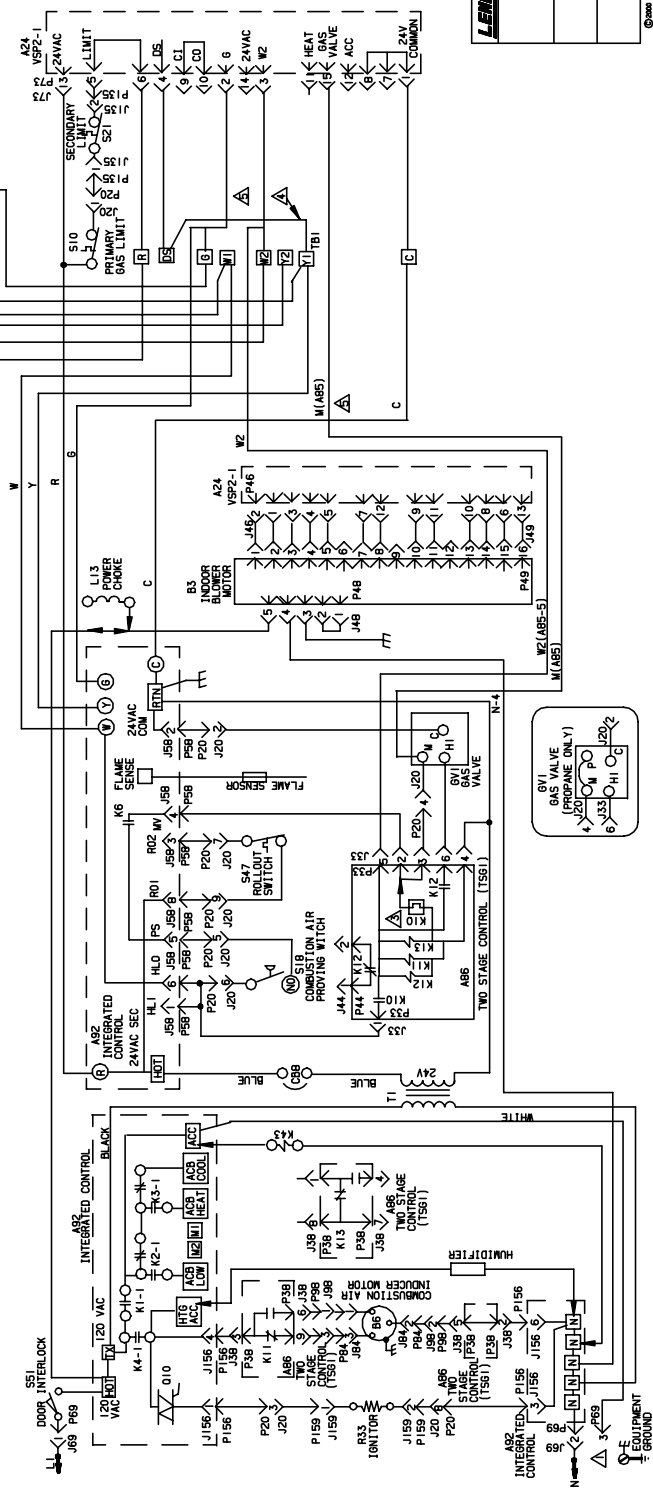
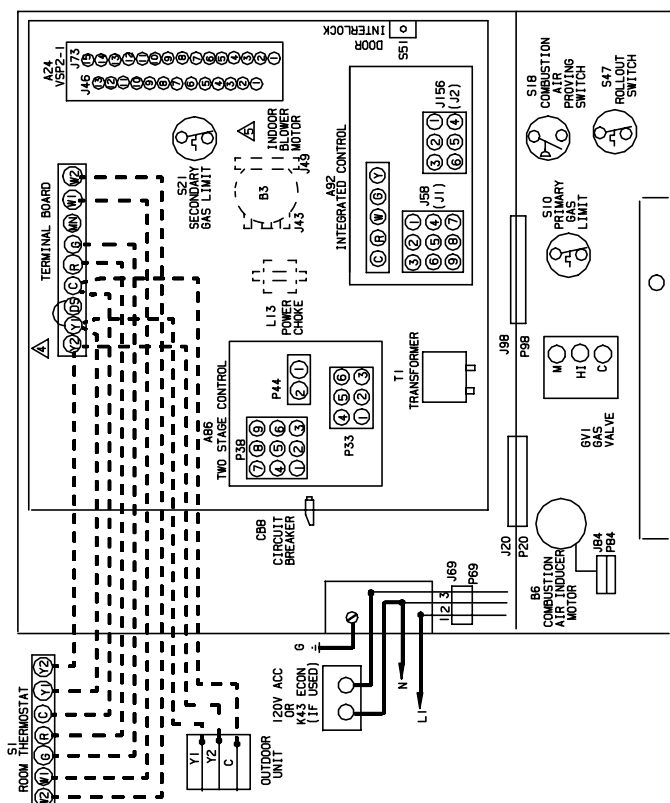

GHR32V -3 UNIT DIAGRAM

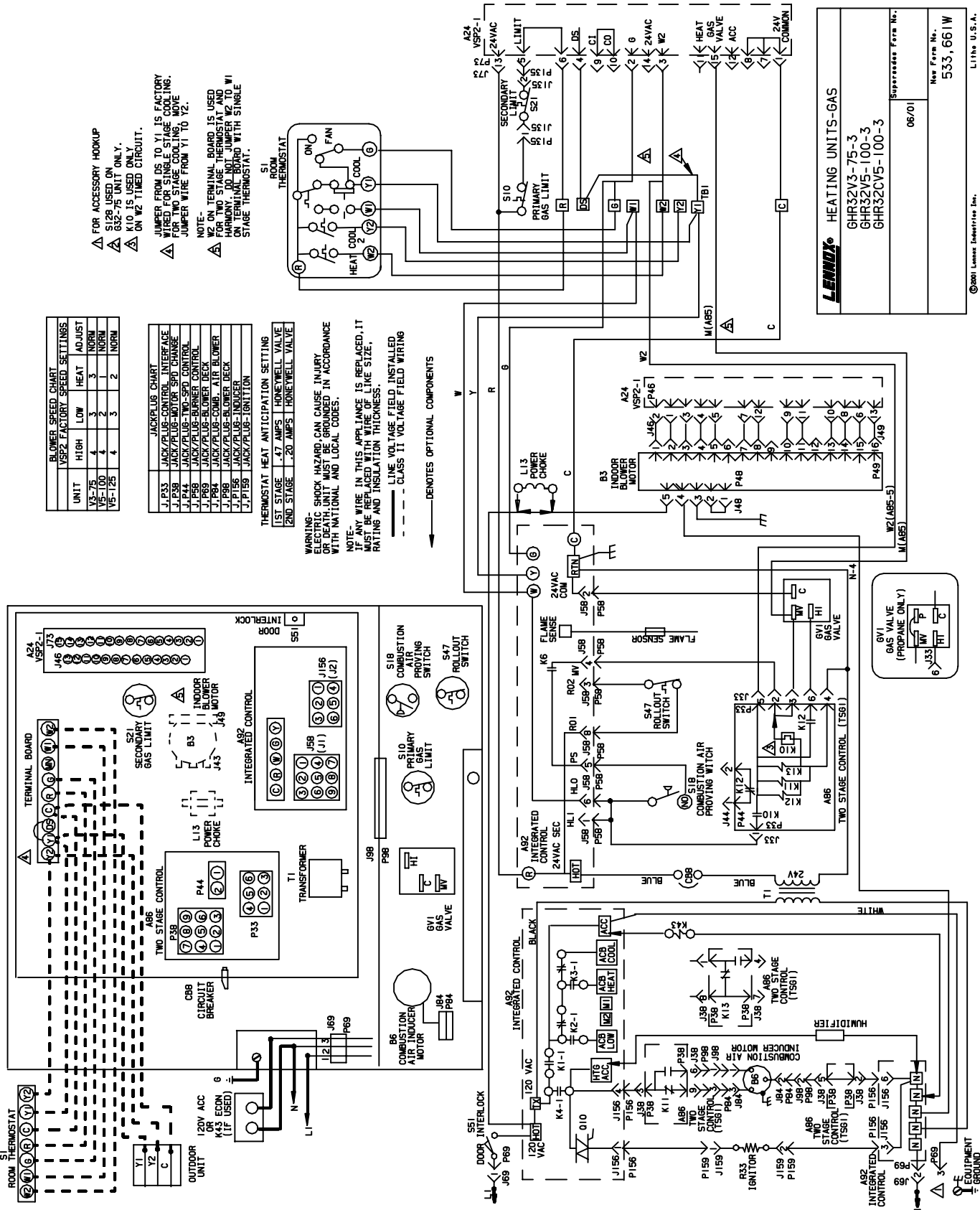

UNIT	HIGH	LOW	HEAT	ADJUST
V5-75	4	3	3	NORM
V5-100	4	2	1	NORM
V5-125	4	3	2	NORM

J.P.33	JACK/PLUG-CONTROL INTERFACE
J.P.38	JACK/PLUG-MOTOR SPD CHANGE
J.P.44	JACK/PLUG-TWO-SPD CONTROL
J.P.59	JACK/PLUG-BURNER DECK
J.P.68	JACK/PLUG-COMB. AIR BLOWER
J.P.69	JACK/PLUG-BLOWER DECK
J.P.86	JACK/PLUG-INDUCER
J.P.87	JACK/PLUG-IGNITION

1ST STAGE 47 AMPS HONEYWELL VALVE
2ND STAGE 27 AMPS HONEYWELL VALVE

WARNING - SHOCK HAZARD - CAN CAUSE INJURY OR DEATH. ALWAYS DISCONNECT IN ACCORDANCE WITH NATIONAL AND LOCAL CODES.

NOTE: IF ANY WIRE IN THIS APPLIANCE IS REPLACED, IT MUST BE REPLACED WITH WIRE OF LIKE SIZE, RATING AND INSULATION THICKNESS.

--- LINE VOLTAGE FIELD INSTALLED
--- CLASS II VOLTAGE FIELD WIRING

--- DENOTES OPTIONAL COMPONENTS

- ▲ FOR ACCESSORY HOOKUP
- ▲ S128 USED ON
- ▲ S129 USED ON
- ▲ S130 USED ON
- ▲ S131 USED ON
- ▲ S132 USED ON
- ▲ S133 USED ON
- ▲ S134 USED ON
- ▲ S135 USED ON
- ▲ S136 USED ON
- ▲ S137 USED ON
- ▲ S138 USED ON
- ▲ S139 USED ON
- ▲ S140 USED ON
- ▲ S141 USED ON
- ▲ S142 USED ON
- ▲ S143 USED ON
- ▲ S144 USED ON
- ▲ S145 USED ON
- ▲ S146 USED ON
- ▲ S147 USED ON
- ▲ S148 USED ON
- ▲ S149 USED ON
- ▲ S150 USED ON
- ▲ S151 USED ON
- ▲ S152 USED ON
- ▲ S153 USED ON
- ▲ S154 USED ON
- ▲ S155 USED ON
- ▲ S156 USED ON
- ▲ S157 USED ON
- ▲ S158 USED ON
- ▲ S159 USED ON
- ▲ S160 USED ON
- ▲ S161 USED ON
- ▲ S162 USED ON
- ▲ S163 USED ON
- ▲ S164 USED ON
- ▲ S165 USED ON
- ▲ S166 USED ON
- ▲ S167 USED ON
- ▲ S168 USED ON
- ▲ S169 USED ON
- ▲ S170 USED ON
- ▲ S171 USED ON
- ▲ S172 USED ON
- ▲ S173 USED ON
- ▲ S174 USED ON
- ▲ S175 USED ON
- ▲ S176 USED ON
- ▲ S177 USED ON
- ▲ S178 USED ON
- ▲ S179 USED ON
- ▲ S180 USED ON
- ▲ S181 USED ON
- ▲ S182 USED ON
- ▲ S183 USED ON
- ▲ S184 USED ON
- ▲ S185 USED ON
- ▲ S186 USED ON
- ▲ S187 USED ON
- ▲ S188 USED ON
- ▲ S189 USED ON
- ▲ S190 USED ON
- ▲ S191 USED ON
- ▲ S192 USED ON
- ▲ S193 USED ON
- ▲ S194 USED ON
- ▲ S195 USED ON
- ▲ S196 USED ON
- ▲ S197 USED ON
- ▲ S198 USED ON
- ▲ S199 USED ON
- ▲ S200 USED ON

JUMPER FROM DS TO Y1 IS FACTORY SET FOR TWO STAGE COOLING WIRING. JUMPER WIRE FROM Y1 TO Y2.

NOTE: W2 ON TERMINAL BOARD IS USED FOR TWO STAGE THERMOSTAT AND HARMONY. DO NOT JUMPER W2 TO W1 ON TERMINAL BOARD WITH SINGLE STAGE THERMOSTAT.

LENOX® HEATING UNITS-GAS

GHR32V3-75-3
GHR32V5-100-3
GHR32CV5-100-3

Supersedes Form No. 06/01

New Form No. 533, 661W

©2001 Lennox Industries Inc. Litho U.S.A.

GHR32V -4 UNIT DIAGRAM

FOR ACCESSORY HOOKUP

- △ 5128 USED ON 652-75 UNIT ONLY.
- △ 5100'S USED ON HEAT PUMP CIRCUIT.
- △ 5100'S USED ON Y1 TO Y2 IS FACTORY WIRE FOR TWO STAGE COOLING REMOVE JUMPER WIRE FROM Y1 TO Y2.
- △ NOTE:
- △ W2 ON TERMINAL BOARD IS USED FOR TWO STAGE THERMOSTAT AND W1 ON TERMINAL BOARD WITH STABLE STAGE THERMOSTAT.
- △ JUMPER FROM O TO R SHOULD BE REMOVED FOR HEAT PUMP APPLICATIONS
- △ REMOVE JUMPER BETWEEN DS AND Y1 WHEN A20 HUMIDITY SENSOR IS USED
- △ L13 POWER CHOKE IS USED ON GHR32V5 MODELS ONLY

BLOWER SPEED CHART			
UNIT	DELAY	COOL	HEAT ADJUST
V3-75	4	4	3
V5-100	4	4	2
V5-125	4	4	4

JACKPLUG CHART			
JACKPLUG	CONTROL	INTERFACE	CHANGE
J-P33	JACK/PLUG	CONTROL	SPD CHANGE
J-P38	JACK/PLUG	MOTOR	SPD CONTROL
J-P44	JACK/PLUG	TWO-SPD	CONTROL
J-P48	JACK/PLUG	BURNER	CONTROL
J-P59	JACK/PLUG	BURNER	DECK
J-P68	JACK/PLUG	BURNER	DECK
J-P75	JACK/PLUG	INDUCER	DECK
J-P78	JACK/PLUG	INDUCER	DECK
J-P79	JACK/PLUG	INDUCER	DECK

TERMOSTAT HEAT ANTICIPATION SETTING
 1ST STAGE .47 AMPS HONEYWELL VALVE
 2ND STAGE .20 AMPS HONEYWELL VALVE

WARNING:
 ELECTRIC SHOCK HAZARD CAN CAUSE INJURY OR DEATH. UNIT MUST BE GROUNDED IN ACCORDANCE WITH NATIONAL AND LOCAL CODES.

NOTE:
 ALL WIRE IN THIS WIRING DIAGRAM IS REPLACED, IT MUST BE REPLACED WITH WIRE OF LIKE SIZE, RATING AND INSULATION THICKNESS.

— LINE VOLTAGE FIELD INSTALLED

— DENOTES OPTIONAL COMPONENTS

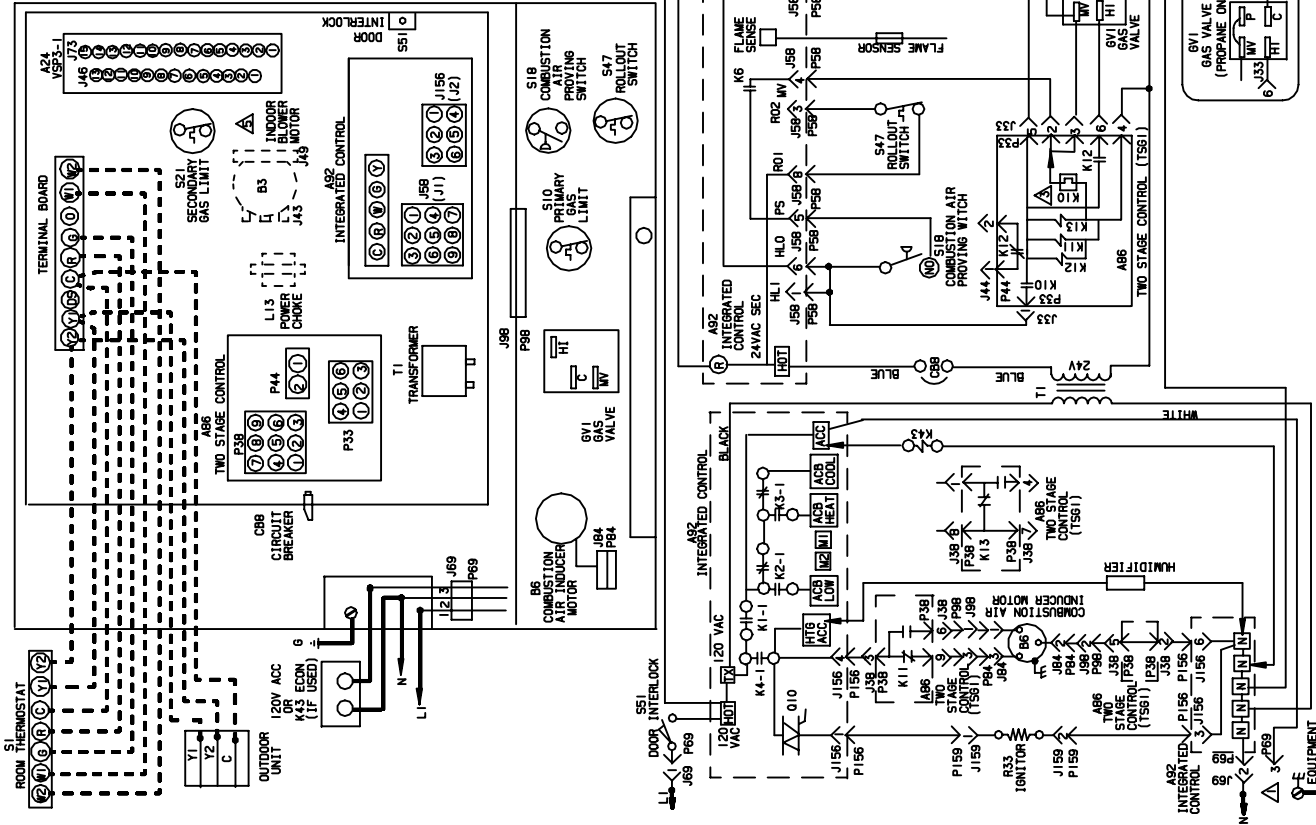

LENDOR® HEATING UNITS-GAS

GHR32V3-75-4
 GHR32V5-100-4
 GHR32CV5-100-4

Supersessor Form No. 08/01
 New Form No. 533, 661W
 533, 819W

©2001 Lennox Industries Inc. LITHO U.S.A.

Sequence of Operation GHR32V -1 / -4 Units

Ignitor operation will vary between SureLight boards. Board 56L83 will energize ignitor for the first second of the 4 second ignition trial. Board 97L48 will energize ignitor during the entire ignition trial until flame is sensed.

- 1 - When there is a call for heat, W1 of the thermostat energizes W of the furnace control with 24VAC.
- 2 - SureLight control runs self-check for S10 primary limit switch normally closed contacts and S18 combustion air prove switch normally open contacts. Follow steps 4 through 8 per respective thermostat.

Single-stage Mode, Single-stage Thermostat

- 3 - SureLight control energizes combustion air inducer B6 on high speed. Combustion air inducer runs until S18 prove switch closes (switch will close within 2-1/2 minutes or control goes into Watchguard-Prove Switch mode). A 15-second pre-purge follows after S18 closes.
- 4 - SureLight control energizes ignitor. A 20-second warm-up period begins.
- 5 - Gas valve is energized on first stage heat (low). Gas valve opens for a 4-second trial for ignition.
- 6 - Flame is sensed, After 8 seconds from when gas valve opens, valve energizes on second stage (high heat).
- 7 - After 45-second delay, indoor blower B3 is energized on heating speed.

Two-stage Mode, Single-stage Thermostat

- 1 - SureLight control energizes combustion air inducer B6 on low speed. Combustion air inducer runs until combustion air proving switch S18 closes (switch will close within 2-1/2 minutes or control goes into Watchguard-Prove Switch mode). A 15-second pre-purge follows once S18 closes.
- 2 - SureLight control energizes ignitor. A 20-second warm-up period begins.
- 3 - Gas valve is energized on first stage. Gas valve opens for a 4-second trial for ignition. Signal is sent from control module to two-stage control board to begin W2 (second-stage) ON delay.
- 4 - Flame is sensed, gas valve remains open for the heat call.
- 5 - After 45-second delay, indoor blower B3 is energized on low speed.
- 6 - Second stage time on delay complete (8, 12, or 15 minutes). Combustion air inducer B6 switches to high speed, indoor blower B3 switches to heating speed and gas valve opens on high heat (second stage.)

Two-stage Mode, Two-stage Thermostat

- 1 - SureLight control energizes combustion air inducer B6 on low speed. Combustion air inducer runs until combustion air inducer switch S18 closes. Switch will close within 2-1/2 minutes or control goes into Watchguard-Proving Switch mode). A 15-second pre-purge follows once S18 closes.
- 2 - SureLight control energizes ignitor. A 20-second warm-up period begins.
- 3 - Gas valve is energized on first stage only. Gas valve opens for a 4-second trial for ignition.
- 4 - Flame is sensed, gas valve remains open for the heat call.
- 5 - After 45-second delay, indoor blower B3 is energized on low speed.
- 6 - Call for second stage heat comes from indoor thermostat (W2).

GHR32V -5 & -6 UNIT DIAGRAM

BLOWER SPEED CHART	
FACTORY SHIPPED SETTINGS	
UNIT	ADJUST
VS-75	2 4 NORM
VS-100	2 4 NORM
VS-125	2 4 NORM

NOTE: SEE INSTALLATION INSTRUCTIONS FOR PROCEDURE TO SET CORRECT BLOWER SPEED FOR SPECIFIC COOLING TONNAGE BEING APPLIED, AND HEATING TEMPERATURE RISE DESIRED.

JACKPLUG CHART	
J.P46	JACK/PLUG-OUTPUT
J.P48	JACK/PLUG-MOTOR VARIABLE SPEED
J.P49	JACK/PLUG-MOTOR VARIABLE SPEED
J.P50	JACK/PLUG-BURNER CONTROL
J.P51	JACK/PLUG-BURNER CONTROL
J.P52	JACK/PLUG-COMB. AIR INDUCER
J.P53	JACK/PLUG-BLOWER DECK
J.P54	JACK/PLUG-BLOWER DECK
J.P55	JACK/PLUG-INDOOR FAN LIMIT
J.P56	JACK/PLUG-INDOOR FAN LIMIT

ROOM THERMOSTAT
S1
HEAT ANTICIPATION SETTING
1. 50 JUMPER WHITE-RODGERS

- △ DS TO R - CUT W914 JUMPER A92 BURNER CONTROL BOARD WHEN A20 HUMIDITY CONTROL (CSB-1) IS USED
- △ R TO O - JUMPER W951 ON A92 BURNER CONTROL BOARD WITH CONDENSING UNITS, DO NOT CUT
- △ Y1 TO Y2 JUMPER FACTORY INSTALLED. LEAVE IN FOR ONE STAGE COOL. THERMOSTAT TWO STAGE COOL. THERMOSTAT. REMOVE JUMPER Y1 TO Y2 FOR TWO STAGE HEAT, COOL COOL. THERMOSTAT.
- △ L13 USED ON 1HP ONLY
- △ FACTORY DEFAULT IS FOR A 2 STAGE THERMOSTAT
- △ USE COPPER CONDUCTORS ONLY
- △ FIELD SUPPLIED ACC WIRE

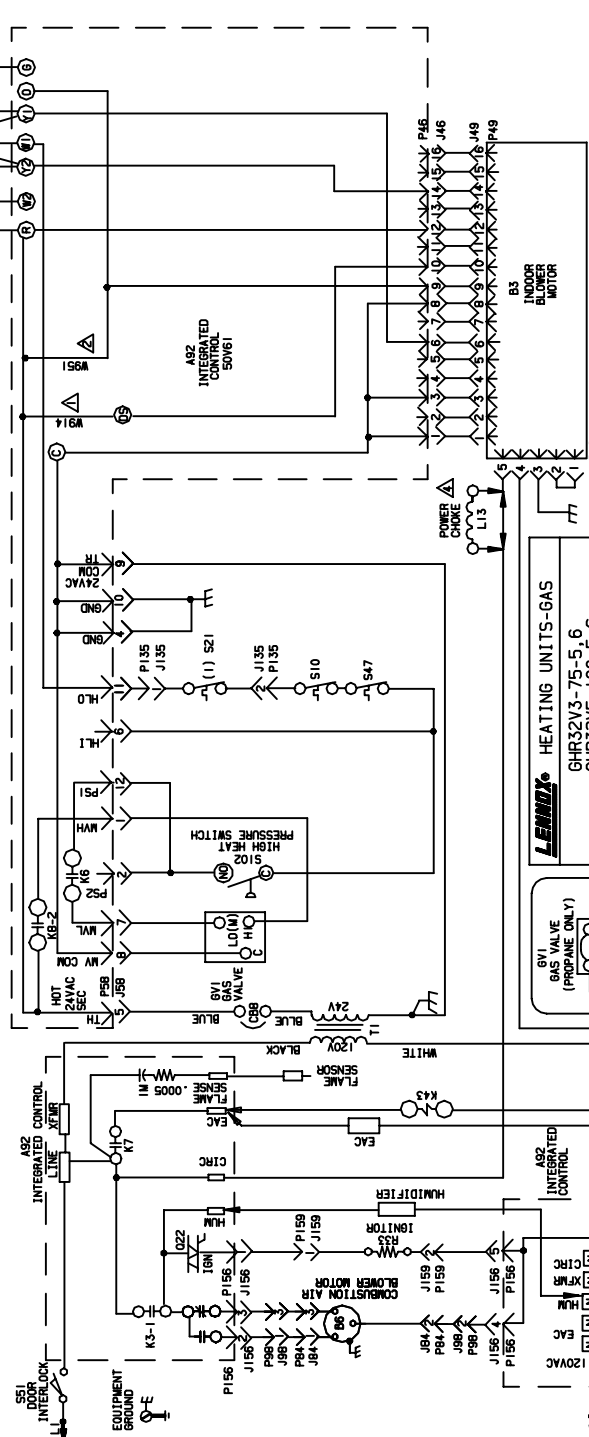
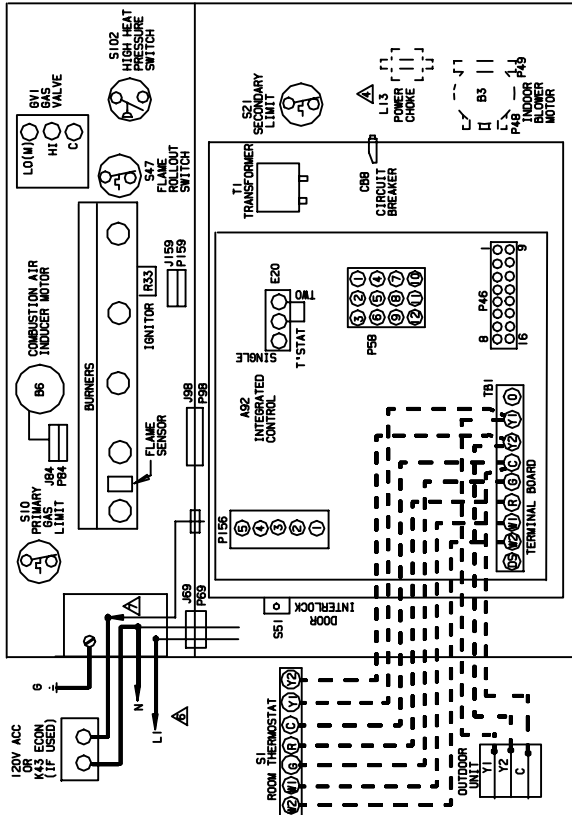

Sequence of Operation GHR32V with SureLight Two Stage Variable Speed Control

Sequence depends on type thermostat used. Units are applicable for single stage or two stage thermostats. Both type thermostats are described below. Thermostat jumper E20 dictates which mode unit will operate in. See flow chart for more sequence detail.

SureLight Control Self Check

When there is a call for heat, the SureLight integrated control runs a self check. The control checks for S10 primary limit, S21 secondary limit (s) and S47 rollout switch normally closed contacts. The control also checks for S102 prove switch normally open contacts. Once self check is complete and all safety switches are operational, heat call can continue.

Two-Stage Thermostat, Two Stage Heat. Jumper E20 set at "TWO".

- 1- SureLight control energizes combustion air inducer B6 on low heat speed. Combustion air inducer runs until S102 prove switch contacts close (switch must close within 2 1/2 minutes or control goes into Watchguard Pressure Switch mode. A 15 second pre-purge follows once S102 closes.
- 2- SureLight control begins 20 second ignitor warm up period.
- 3- Gas valve opens on first stage for a 4 second trial for ignition. Ignitor stays energized during the trial or until flame sensed.
- 4- Flame is sensed, gas valve remains on first stage heat, ignitor de-energizes.
- 5- After 45 second delay, indoor blower B3 is energized on low heat speed.
The furnace will stay in this mode until first stage demand is satisfied OR a second stage heat demand is initiated.
- 6- Second stage heat demand initiated. A 30 second second stage recognition period begins.
- 7- The combustion air inducer ramps up to high heat speed.
- 8- B3 indoor blower ramps up to high heat speed.

Single-Stage Thermostat, Two Stage Heat. Jumper E20 set at "SINGLE"

- 1- SureLight control energizes combustion air inducer B6 on low heat speed. Combustion air inducer runs until S102 prove switch contacts close (switch must close within 2 1/2 minutes or control goes into Watchguard Pressure Switch mode. A 15 second pre-purge follows once S102 closes.
- 2- SureLight control begins 20 second ignitor warm up period.
- 3- Gas valve opens on first stage for a 4 second trial for ignition. Ignitor stays energized during the trial or until flame sensed.
- 4- Flame is sensed, gas valve remains on first stage heat, ignitor de-energizes.
- 5- After 45 second delay, indoor blower B3 is energized on low heat speed.
- 6- A 10 minute (factory set) or 15 minute (field set) second stage heat delay period begins.
- 7- The combustion air inducer ramps up to high heat speed.
- 8- B3 indoor blower ramps up to high heat speed.

VIII-Sequence of Operation Flow Charts
GHR32Q -1 & -3 GHR32V-1 / -4

HEATING SEQUENCE OF OPERATION

NOTE: LED REFERS TO SURELIGHT CONTROL . LED-DS REFERS TO VSP CONTROL.

NORMAL HEATING MODE

ABNORMAL HEATING MODE

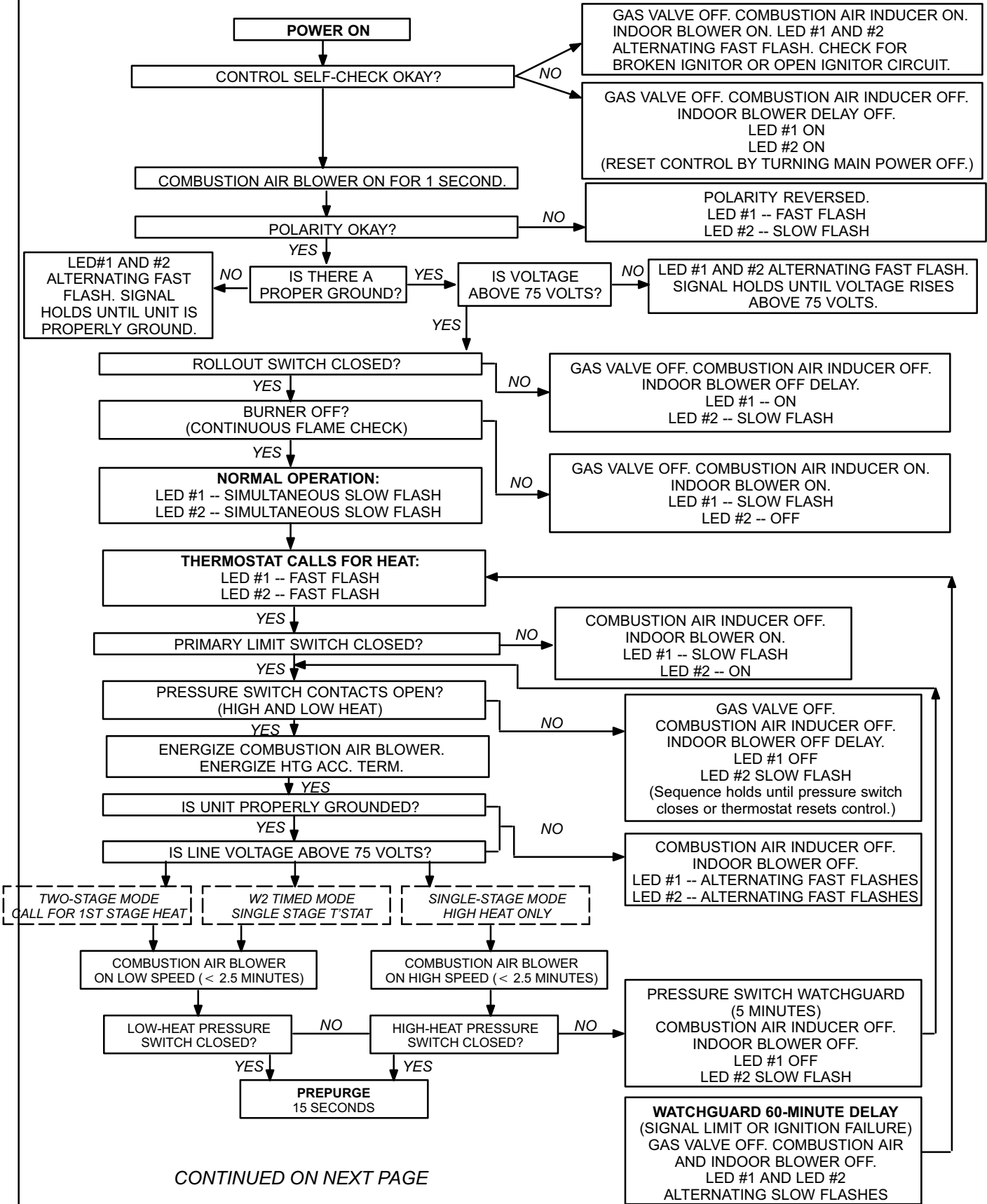

CONTINUED ON NEXT PAGE

HEATING SEQUENCE CONTINUED

NORMAL HEATING MODE

ABNORMAL HEATING MODE

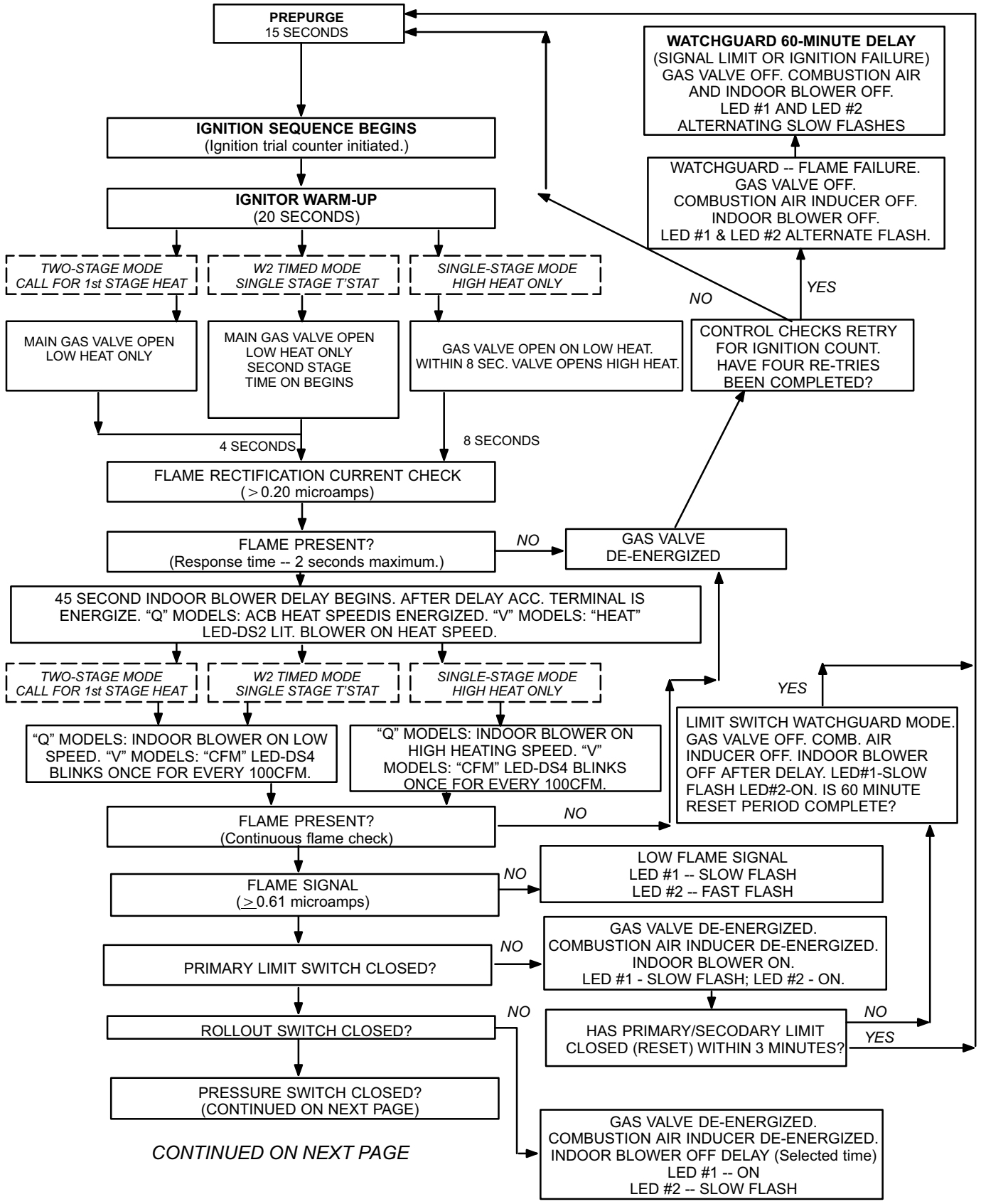

HEATING SEQUENCE CONTINUED

NORMAL HEATING MODE

ABNORMAL HEATING MODE

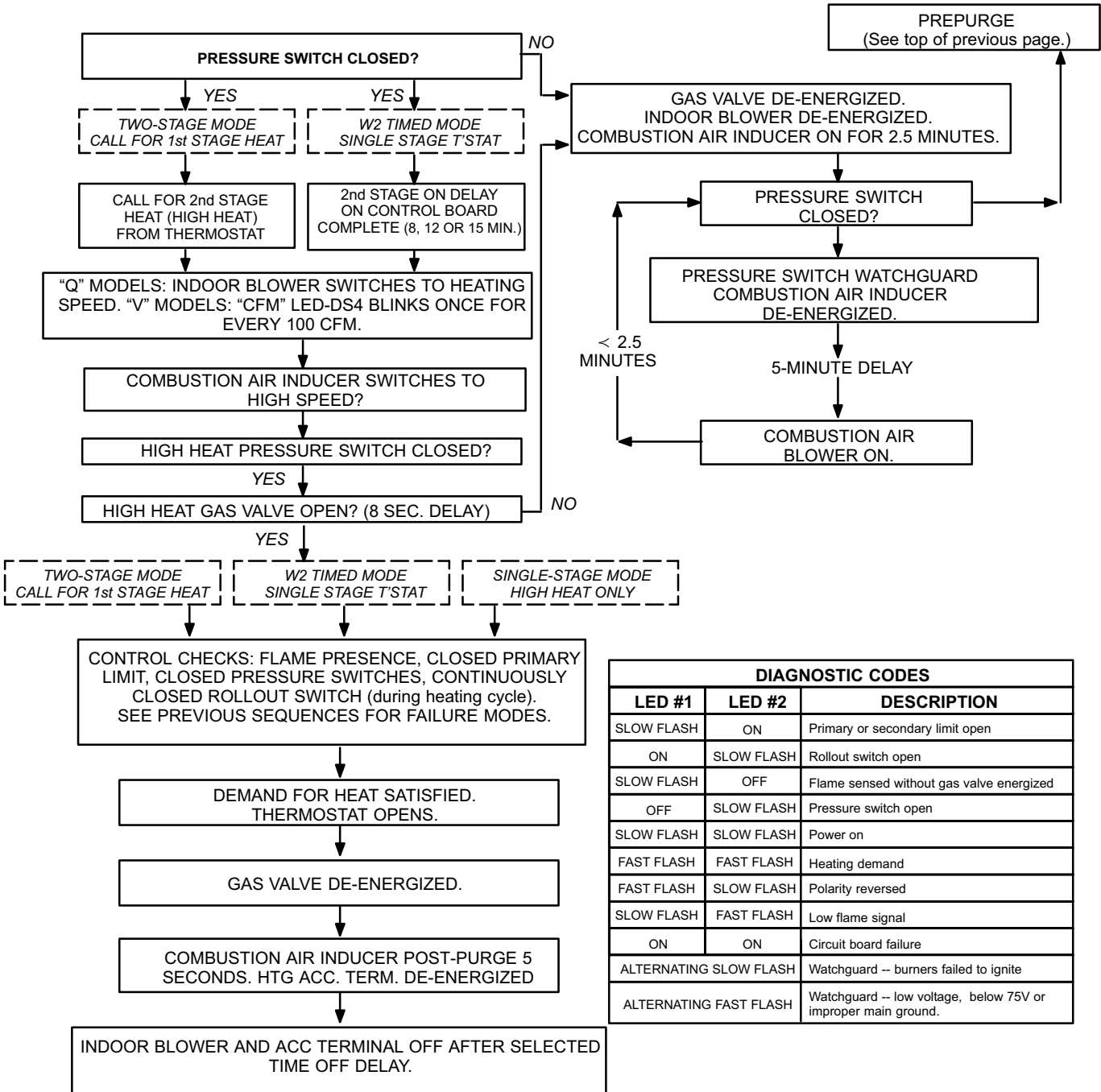

DIAGNOSTIC CODES		
LED #1	LED #2	DESCRIPTION
SLOW FLASH	ON	Primary or secondary limit open
ON	SLOW FLASH	Rollout switch open
SLOW FLASH	OFF	Flame sensed without gas valve energized
OFF	SLOW FLASH	Pressure switch open
SLOW FLASH	SLOW FLASH	Power on
FAST FLASH	FAST FLASH	Heating demand
FAST FLASH	SLOW FLASH	Polarity reversed
SLOW FLASH	FAST FLASH	Low flame signal
ON	ON	Circuit board failure
ALTERNATING SLOW FLASH		Watchguard -- burners failed to ignite
ALTERNATING FAST FLASH		Watchguard -- low voltage, below 75V or improper main ground.

COOLING SEQUENCE OF OPERATION

NORMAL COOLING MODE

ABNORMAL COOLING MODE

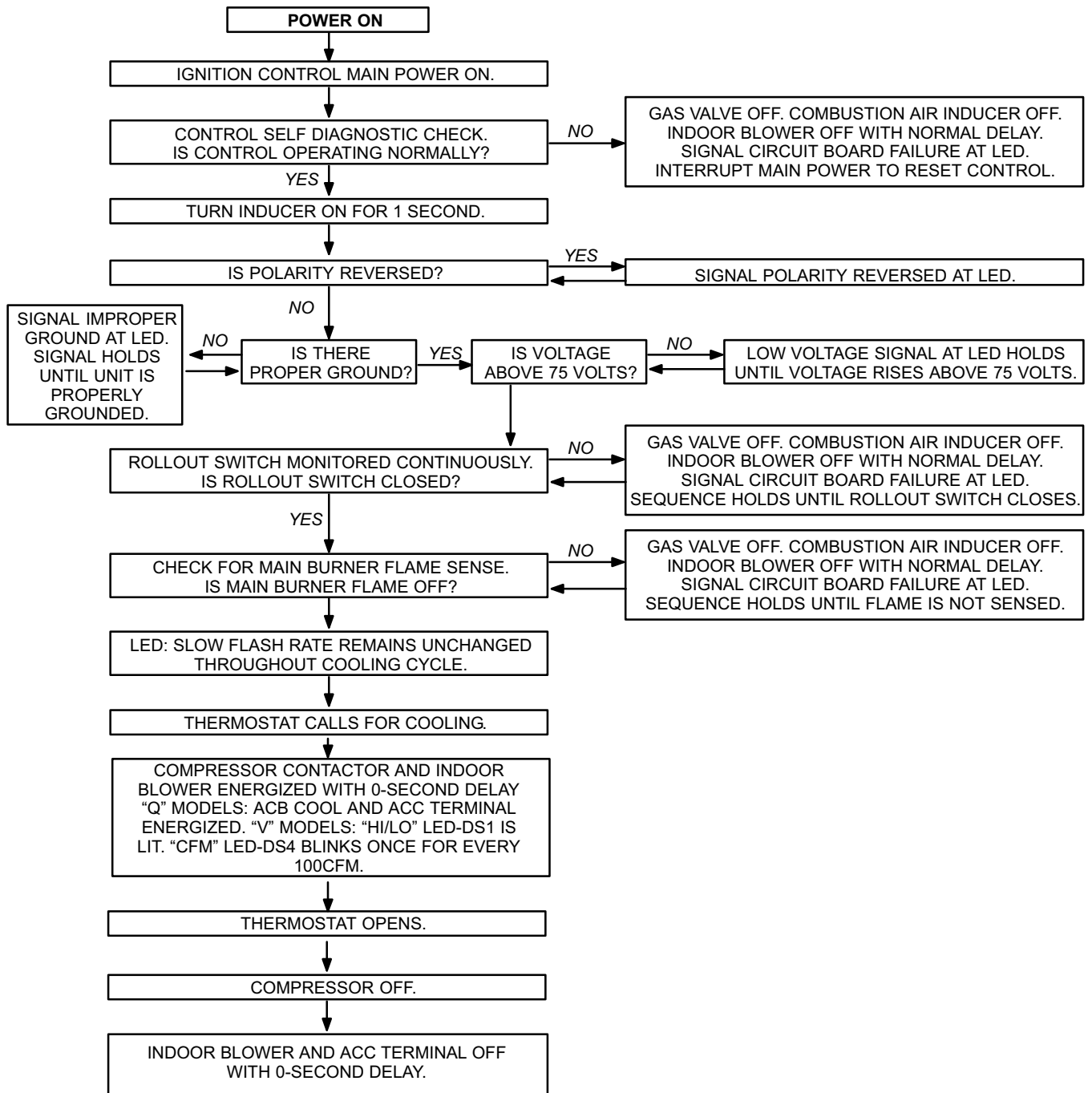

CONTINUOUS LOW SPEED FAN SEQUENCE OF OPERATION

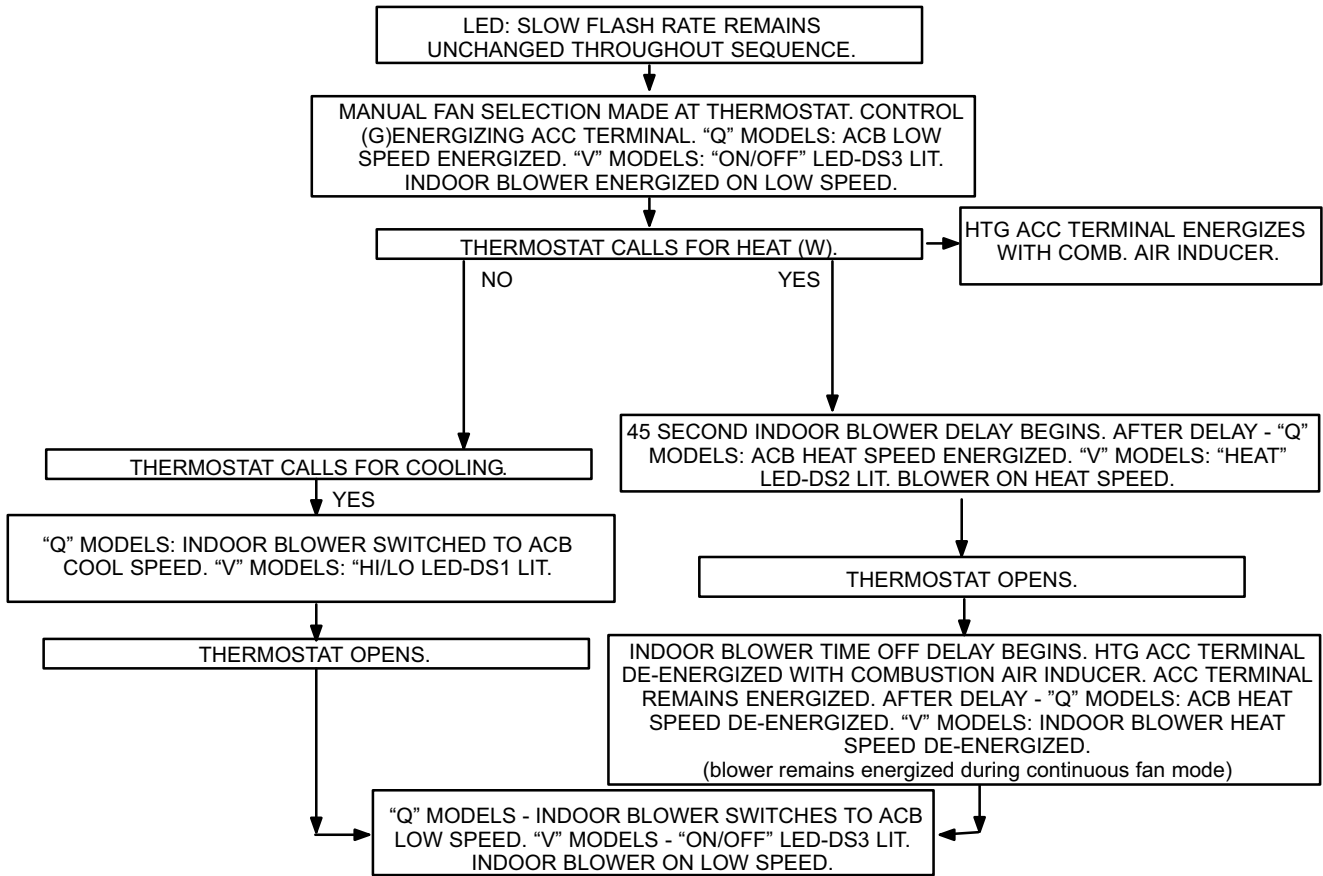

GHR32Q with Two Stage Control and GHR32V with Two Stage Variable Speed Control

HEATING SEQUENCE OF OPERATION NORMAL AND ABNORMAL HEATING MODE

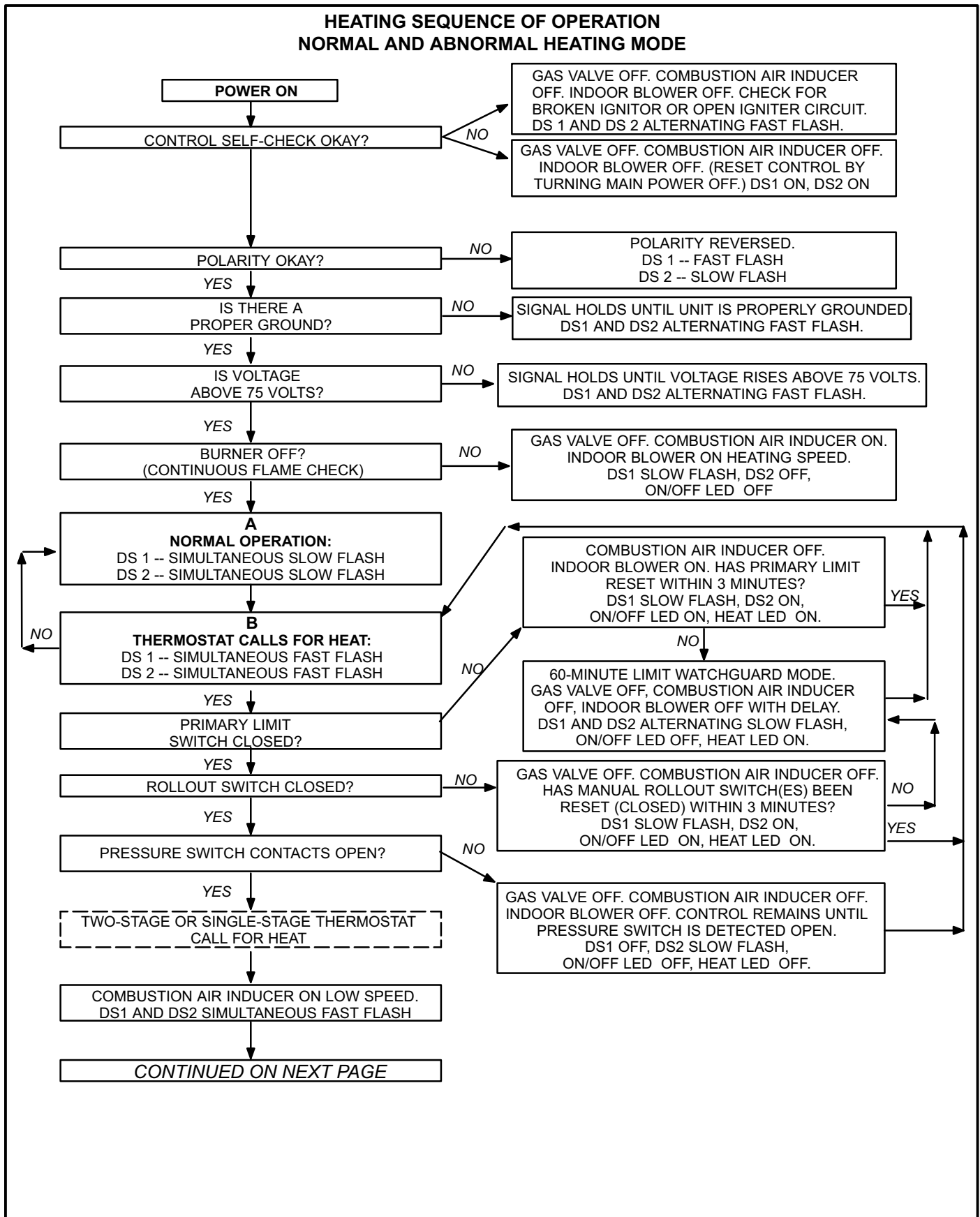

HEATING SEQUENCE OF OPERATION

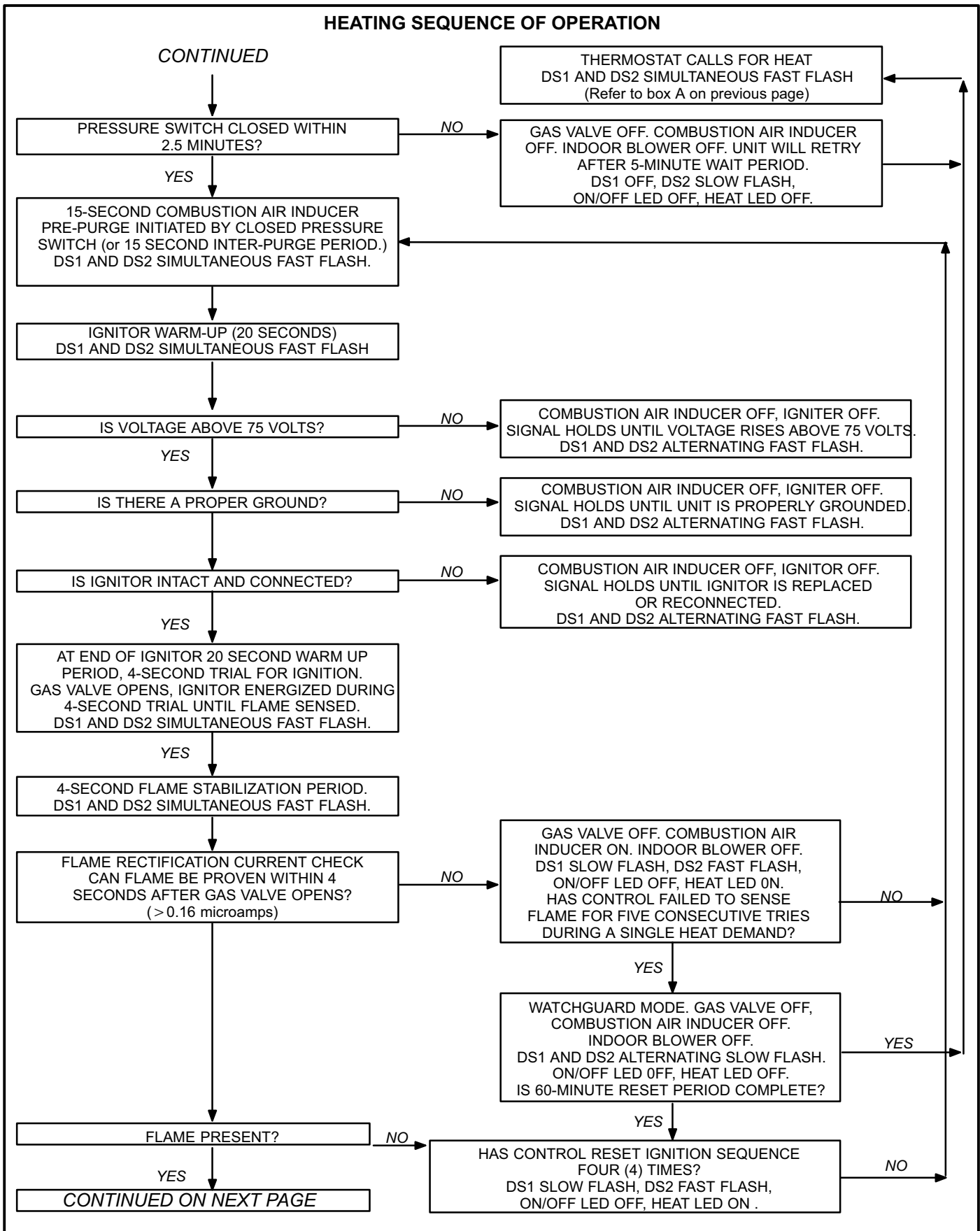

HEATING SEQUENCE OF OPERATION

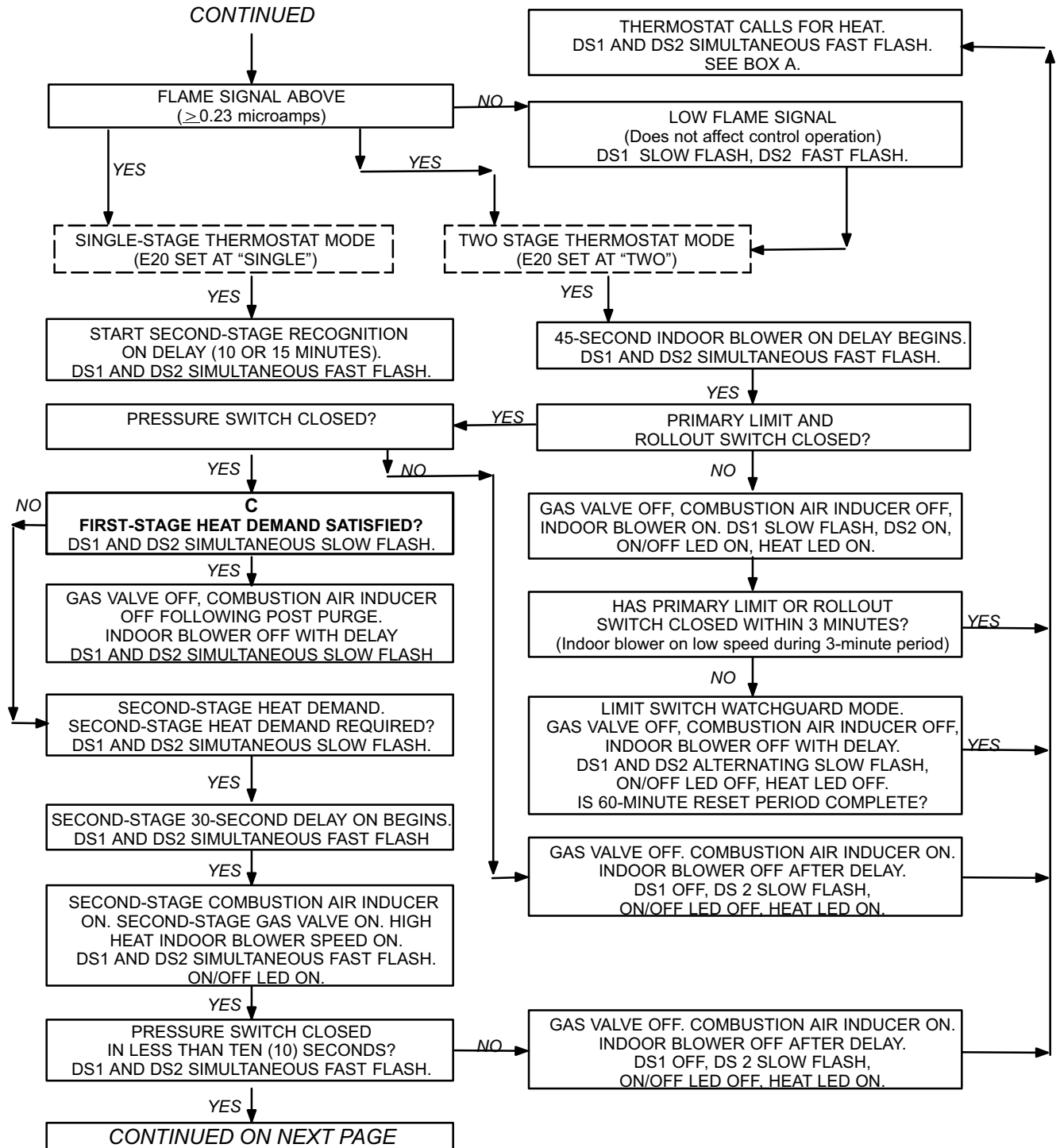

HEATING SEQUENCE OF OPERATION

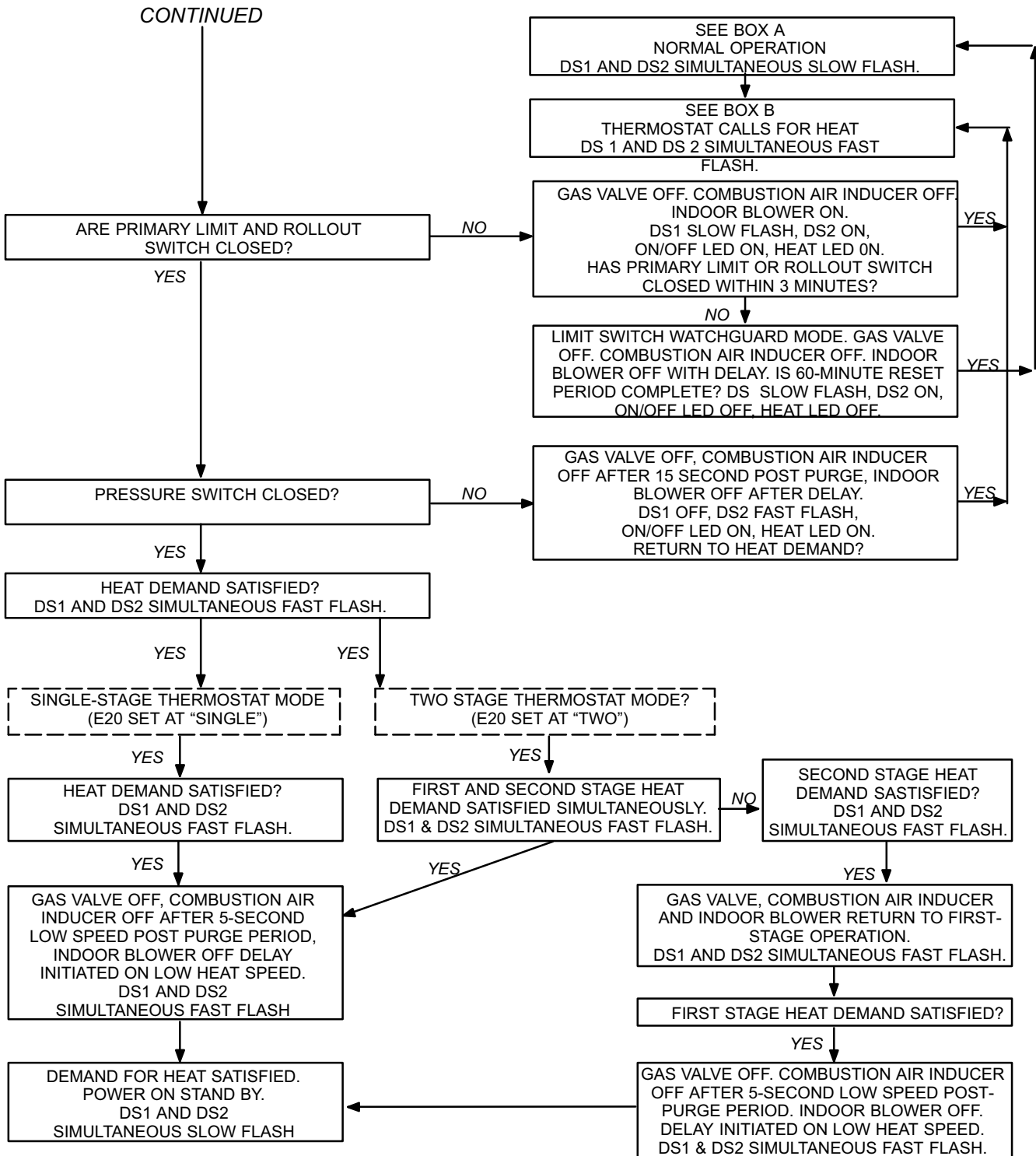

COOLING SEQUENCE OF OPERATION

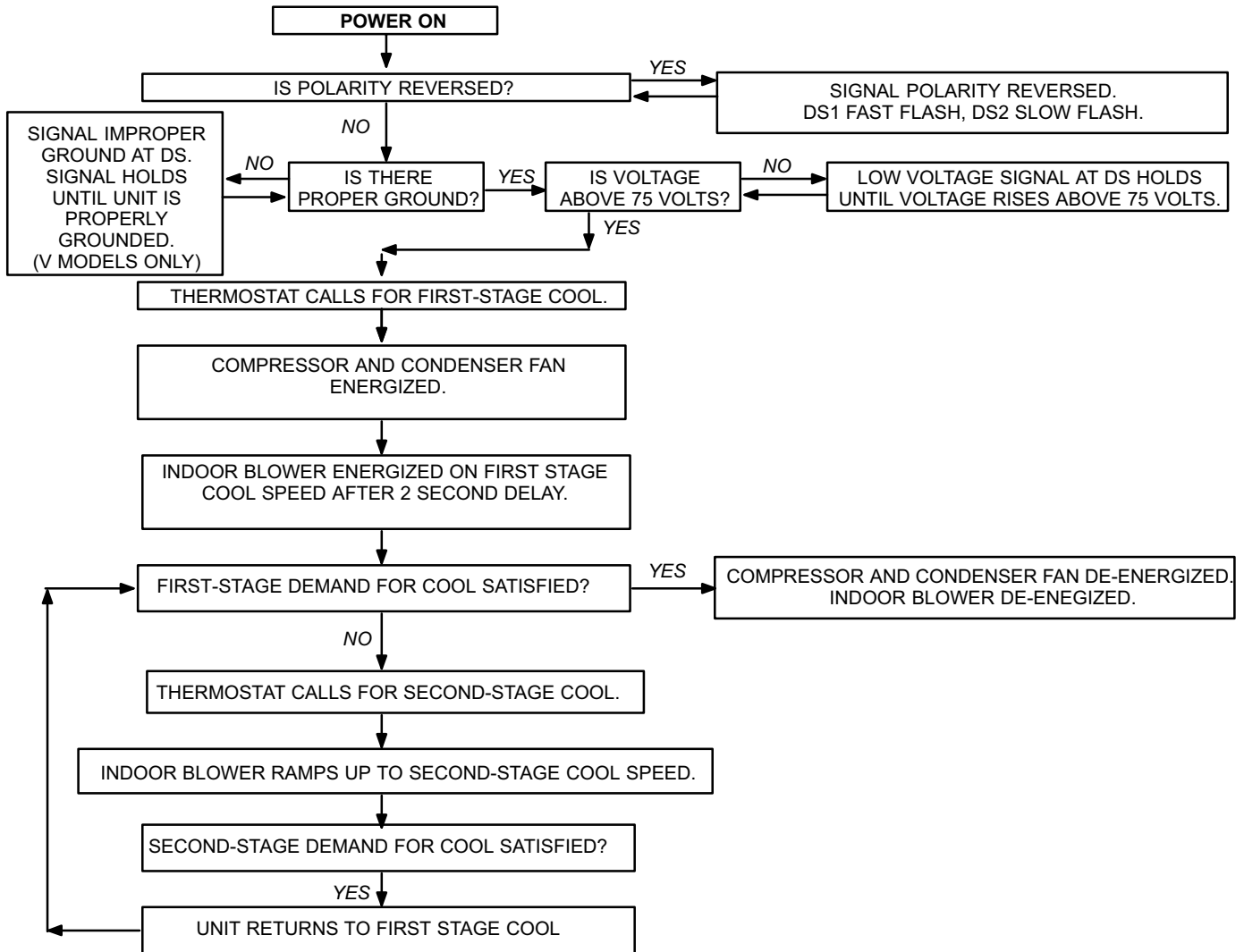

CONTINUOUS LOW SPEED FAN SEQUENCE OF OPERATION

GHR32V-5 UNITS

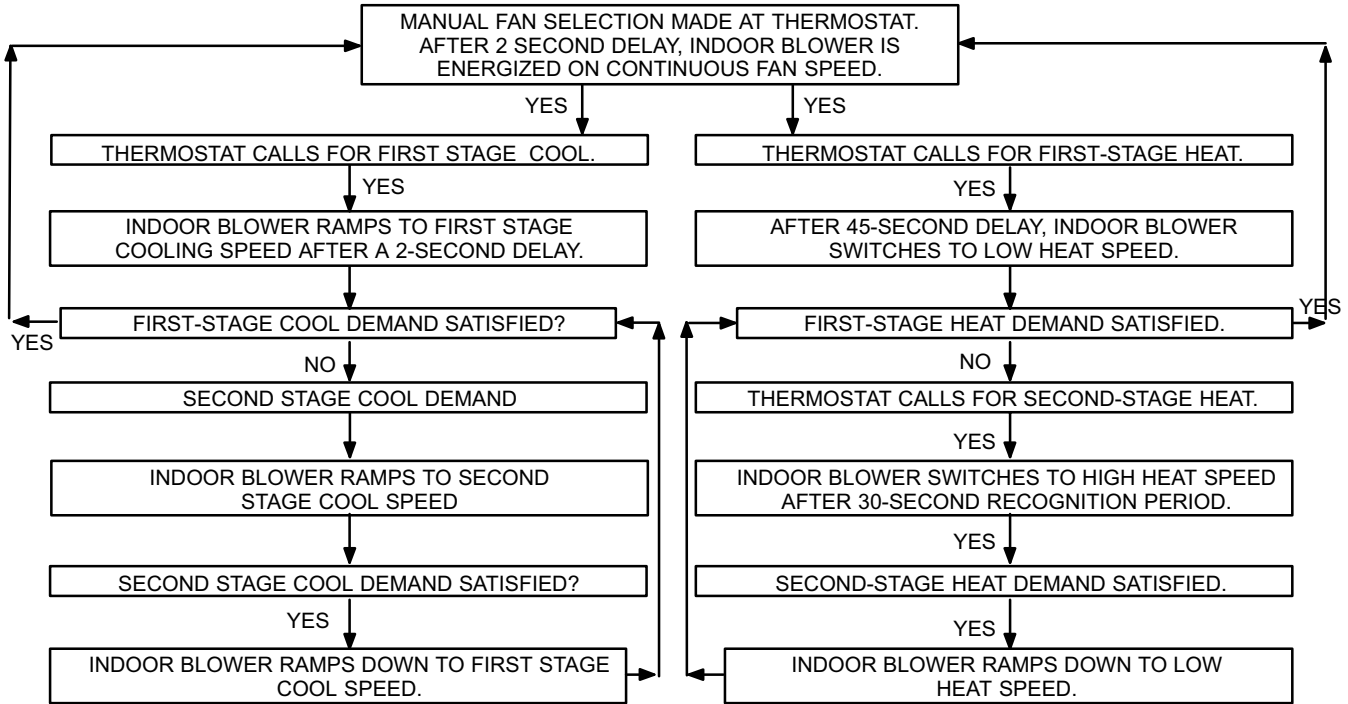

GHR32Q-5 UNITS

NOTE - Continuous low speed fan and cooling low speed are equal to the low heat fan speed.

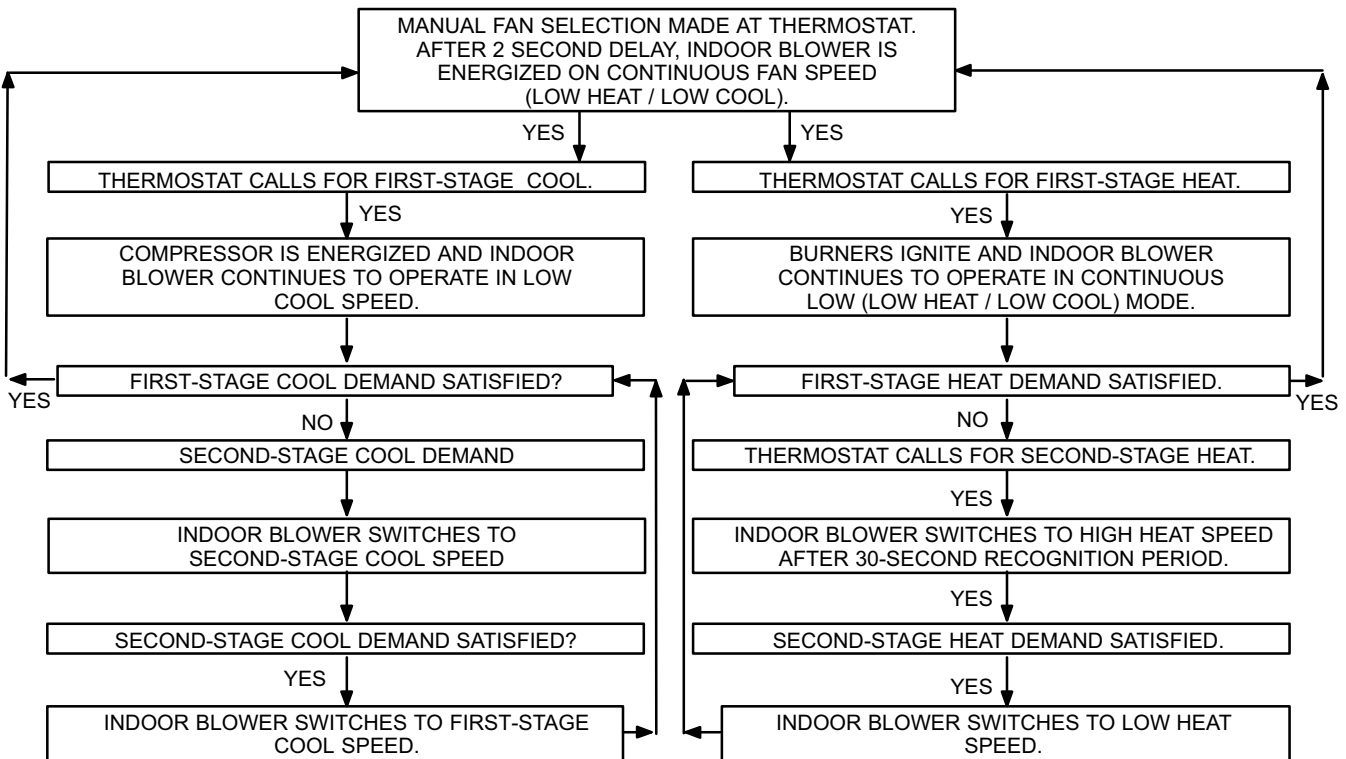

**IX- Troubleshooting
SureLight Control**

UPON INITIAL POWER UP, REMOVE ALL THERMOSTAT DEMANDS TO THE UNIT

Unless otherwise noted, condition applies to all GHR32Q/V units.

PROBLEM: 1 UNIT FAILS TO OPERATE IN THE COOLING, HEATING, OR CONTINUOUS FAN MODE		
Condition	Possible Cause	Corrective Action / Comments
<p>1.1</p> <p>- Both diagnostic lights fail to light up.</p> <p>LED#1-Off LED#2-Off</p>	<p>1.1.1</p> <p>Main voltage 120V not supplied to unit.</p>	<p>ACTION 1 - Check 120V main voltage. Determine cause of main power failure.</p>
	<p>1.1.2</p> <p>Miswiring of furnace or improper connections.</p>	<p>ACTION 1 - Check for correct wiring of 120V to power make up box and transformer. ACTION 2 - Check 24V wiring to control board.</p>
	<p>1.1.3</p> <p>Circuit breaker tripped or fails to close.</p>	<p>ACTION 1 - Replace circuit breaker if it is reset but does not have continuity. ACTION 2 - If circuit breaker still trips, check for short.</p>
	<p>1.1.4</p> <p>Door interlock switch failure.</p>	<p>ACTION 1 - Check that door switch is activated when door is closed. ACTION 2 - Check wire connections to switch, replace loose connectors. ACTION 3 - Check continuity of switch in closed position. Replace if malfunctioning</p>
	<p>1.1.5</p> <p>Transformer Failure.</p>	<p>ACTION 1 - Check that transformer output is 24V. Replace if malfunctioning</p>
	<p>1.1.6</p> <p>Failed control board.</p>	<p>ACTION 1 - If all the above items have been checked, replace board.</p>
<p>1.2</p> <p>GHR32Q/V-1 through -4 Units Only</p> <p>- Diagnostic lights flash the roll-out code.</p> <p>LED#1-On, LED#2-Slow Flash</p>	<p>1.2.1</p> <p>Roll-out switch open.</p>	<p>ACTION 1 - Manually reset the roll-out switch by pushing the top button. ACTION 2 - Determine the cause of the roll-out switch activation before leaving furnace.</p>
	<p>1.2.2</p> <p>Roll-out switch failure.</p>	<p>ACTION 1 - Check continuity across roll-out switch. Replace roll-out switch if switch is reset but does not have continuity.</p>
	<p>1.2.3</p> <p>Miswiring or improper connections at roll-out switch.</p>	<p>ACTION 1 - Check wiring connections to switch.</p>
	<p>1.2.4</p> <p>Nine pin connector failure</p>	<p>ACTION 1 - Check 9-pin connector for proper connection to control board. ACTION 2 - Check continuity of the multi plug pin.</p>
<p>1.3</p> <p>- On initial power-up the comb. air blower does not energize. - Diagnostic lights flash the reverse polarity code.</p> <p>LED#1-Fast Flash, LED#2-Slow Flash.</p>	<p>1.3.1</p> <p>120V main power polarity reversed.</p>	<p>ACTION 1 - Check the 120V has line and neutral correctly input into control. ACTION 2 - Reverse the line and neutral at the 120V field connection.</p>
<p>1.4</p> <p>GHR32Q/V-1 through -4 Units Only</p> <p>- On initial power up the combustion air blower does not energize. - Diagnostic lights flash normal power on operation.</p> <p>LED#1-Slow Flash LED#2-Slow Flash</p>	<p>1.4.1</p> <p>Open combustion air blower motor circuit.</p>	<p>ACTION 1 - Check for 120V to combustion air blower. If no power, check wire and connections.</p>
	<p>1.4.2</p> <p>Failed combustion air blower motor.</p>	<p>ACTION 1 - If power is present at blower, replace blower.</p>

PROBLEM 1: UNIT FAILS TO OPERATE IN THE COOLING, HEATING, OR CONTINUOUS FAN MODE

Condition	Possible Cause	Corrective Action / Comments
<p>1.5</p> <ul style="list-style-type: none"> - On initial power-up the combustion air blower remains energized. - Diagnostic lights flash the improper main ground. <p>LED#1-Alternating Fast Flash LED#2-Alternating Fast Flash</p>	<p>1.5.1</p> <p>Improper ground to the unit.</p>	<p>ACTION 1 - Check that the unit is properly grounded.</p> <p>ACTION 2 - Install a proper main ground to the unit</p>
	<p>1.5.2</p> <p>6-Pin connector is improperly attached to the circuit board.</p>	<p>ACTION 1 - Check 6-pin connector for proper installation. Correctly insert connector into control.</p>
	<p>1.5.3</p> <p>Line voltage is below 75V.</p>	<p>ACTION 1 - Check that the line voltage is above 75V. Determine cause of voltage drop and supply correct voltage to the control.</p>

PROBLEM 2: UNIT FAILS TO OPERATE IN THE COOLING OR HEATING MODE, BUT COMBUSTION AIR BLOWER OPERATES CONTINUOUS. GHR32Q/V-1 through -4 UNITS WITH CONTROL BOARDS DATE CODED AFTER NOV.1 1997, WILL OPERATE IN COOLING WITH COMBUSTION AIR BLOWER CYCLING 5 SECONDS ON 55 SECONDS OFF, BUT NOT IN THE HEATING MODE.

Condition	Possible Cause	Corrective Action / Comments
<p>2.1</p> <ul style="list-style-type: none"> - On initial power-up the combustion air blower remains energized. - Diagnostic lights flash the improper main ground. - G32V-1 to -4 Units with control boards date coded after Nov.1 1997; combustion air blower will cycle 5 seconds on 55 seconds off. <p>LED#1-Alternating Fast Flash LED#2-Alternating Fast Flash</p>	<p>2.1.1</p> <p>Open ignitor circuit.</p>	<p>ACTION 1 - Check for correct wiring and loose connections in the ignitor circuit. Check multi-plug connections for correct installation.</p>
	<p>2.1.2</p> <p>Broken or failed ignitor.</p>	<p>ACTION 1 - Unplug ignitor and read resistance across ignitor. If resistance does not read between 10.9 and 19.7 ohms, replace the ignitor.</p>

PROBLEM 3: UNIT FAILS TO FIRE IN THE HEATING MODE, COMBUSTION AIR BLOWER DOES NOT ENERGIZE

Condition	Possible Cause	Corrective Action / Comments
<p>3.1</p> <ul style="list-style-type: none"> -Unit operates with a cooling or continuous fan demand. - Combustion air blower will not start with a Heating demand. - Diagnostic lights flash the limit failure mode. <p>LED#1-Slow Flash, LED#2-On</p>	<p>3.1.1</p> <p>Primary or secondary (if equipped) or rollout limit switch open.</p>	<p>ACTION 1 - Check continuity across switch(es). Switches reset automatically upon cool down. Rollout switch must be reset manually.</p> <p>ACTION 2 - Check for restrictions on blower inlet air (including filter) and outlet air. Determine cause for limit activation before placing unit back in operation.</p>
	<p>3.1.2</p> <p>Miswiring of furnace or improper connections at limit switch(es).</p>	<p>ACTION 1 - Check for correct wiring and loose connections. Correct wiring and/or replace any loose connections.</p>
<p>3.2</p> <ul style="list-style-type: none"> - Unit operates with a cooling and continuous fan demand. - Combustion air blower will not start with a Heating demand. - Diagnostic lights flash the pressure switch failure code. <p>LED#1-Off, LED#2-Slow Flash</p>	<p>3.2.1</p> <p>Miswiring of furnace or improper connections to combustion air blower.</p>	<p>ACTION 1 - Check for correct wiring and loose connections. Correct wiring and/or replace any loose connections.</p>
	<p>3.2.2</p> <p>Pressure switch stuck closed.</p>	<p>ACTION 1 - Check that the pressure switch is open without the combustion air blower operating. Replace if malfunctioning</p>

PROBLEM 3: UNIT FAILS TO FIRE IN THE HEATING MODE, COMBUSTION AIR BLOWER DOES NOT ENERGIZE (CONT.).

Condition	Possible Cause	Corrective Action/Comments
<p>3.3</p> <ul style="list-style-type: none"> - Unit operates with a cooling and continuous fan demand. - Combustion air blower will not start with a Heating demand. - Diagnostic lights flash the pressure switch failure code 2.5 minutes after heating demand. <p>LED#1-Off, LED#2-Slow Flash</p>	<p>3.3.1</p> <p>Miswiring of furnace or improper connections to combustion air blower.</p>	<p>ACTION 1 - Check for correct wiring and loose connections. Correct wiring and/or replace any loose connections.</p>
	<p>3.3.2</p> <p>Combustion air blower failure.</p>	<p>ACTION 1 - If there is 120V to combustion air blower and it does not operate, replace combustion air blower.</p>

PROBLEM 4: UNIT FAILS TO FIRE IN THE HEATING MODE, COMBUSTION AIR BLOWER ENERGIZES, IGNITOR IS NOT ENERGIZED.

Condition	Possible Cause	Corrective Action/Comments
<p>4.1</p> <ul style="list-style-type: none"> - Unit operates with a cooling and continuous fan demand. - Combustion air blower energizes with a heating demand. - Diagnostic lights flash the pressure switch failure code 2.5 minutes after heating demand. <p>LED#1-Off LED#2-Slow Flash</p>	<p>4.1.1</p> <p>Pressure switch does not close due to incorrect routing of the pressure switch tubing.</p>	<p>ACTION 1 - Check that the pressure switch tubing is correctly routed. Correctly route pressure switch tubing.</p>
	<p>4.1.2</p> <p>Pressure switch does not close due to obstructions in the pressure tubing.</p>	<p>ACTION 1 - Remove any obstructions from the pressure tubing and/or taps.</p>
	<p>4.1.3</p> <p>Pressure switch tubing damaged</p>	<p>ACTION 1 - Check pressure switch tubing for leaks. Replace any broken tubing.</p>
	<p>4.1.4</p> <p>Condensate in pressure switch tubing.</p>	<p>ACTION 1 - Check pressure switch tubing for condensate. Remove condensate from tubing. Check that the condensate tubing is located correctly.</p>
	<p>4.1.5</p> <p>Pressure switch does not close due to a low differential pressure across the pressure switch.</p>	<p>ACTION 1 - Check the differential pressure across the pressure switch. This pressure should exceed the set point listed on the switch. ACTION 2 - Check for restricted inlet and exhaust vent. Remove all blockage. ACTION 3 - Check for proper vent sizing and run length. See installation instructions.</p>
	<p>4.1.6</p> <p>Wrong pressure switch installed in the unit, or pressure switch is out of calibration.</p>	<p>ACTION 1 - Check that the proper pressure switch is installed in the unit. Replace pressure switch if necessary.</p>
	<p>4.1.7</p> <p>Miswiring of furnace or improper connections at pressure switch.</p>	<p>ACTION 1 - Check for correct wiring and loose connections. Correct wiring and/or replace any loose connections.</p>
	<p>4.1.8</p> <p>Pressure switch failure.</p>	<p>ACTION 1 - If all the above modes of failure have been checked, the pressure switch may have failed. Replace pressure switch and determine if unit will operate.</p>

PROBLEM 5: UNIT FAILS TO FIRE IN THE HEATING MODE, COMBUSTION AIR BLOWER ENERGIZES, IGNITOR IS ENERGIZED. (CONT.)

Condition	Possible Cause	Corrective Action/Comments
<p align="center">5.1</p> <ul style="list-style-type: none"> - Unit operates with a cooling and continuous fan demand. - Combustion air blower energizes with Heating demand. - Ignitor is energized but unit fails to light. <p>LED#1-Alternating Slow Flash LED#2-Alternating Slow Flash</p>	<p align="center">5.1.1</p> <p>Check that gas is being supplied to the unit.</p>	<p>ACTION 1 - Check line pressure at the gas valve. Pressure should not exceed 13" WC for both natural and propane. Line pressure should read a minimum 4.5" WC for natural and 8.0"WC for propane.</p>
	<p align="center">5.1.2</p> <p>Miswiring of gas valve or loose connections at multi-pin control amp plugs or valve.</p>	<p>ACTION 1 - Check for correct wiring and loose connections. Correct wiring and/or replace any loose connections.</p>
	<p align="center">5.1.3</p> <p>Malfunctioning gas valve or ignition control.</p>	<p>ACTION 1 - Check that 24V is supplied to the gas valve approximately 35 seconds after heat demand is initiated. ACTION 2 - Replace the valve if 24V is supplied but valve does not open (check for excessive gas line pressure before replacing gas valve). ACTION 3 - Replace the control board if 24V is not supplied to valve.</p>

PROBLEM 6: BURNERS LIGHT WITH A HEATING DEMAND BUT UNIT SHUTS DOWN PREMATURELY

Condition	Possible Cause	Corrective Action/Comments
<p align="center">6.1</p> <ul style="list-style-type: none"> - Burners fire with a heating demand. - Burners light but unit shuts off prior to satisfying T-stat demand. - Diagnostic lights flash the pressure switch code. <p>LED#1-Off LED#2-Slow Flash</p>	<p align="center">6.1.1</p> <p>Wrong concentric vent kit used for terminating the unit.</p>	<p>ACTION 1 - Check vent termination kit installed. 1-1/2" dia. concentric vent (kit60G77) for 50 and 75 inputs and 2" dia. concentric vent (kit 33K97) for 100 &125 inputs.</p>
	<p align="center">6.1.2</p> <p>Condensate drain line is not draining properly.</p>	<p>ACTION 1 - Check condensate line for proper vent slope, and any blockage. Condensate should flow freely during operation of furnace. Repair or replace any improperly installed condensate lines.</p>
	<p align="center">6.1.3</p> <p>Low pressure differential at the pressure switch.</p>	<p>ACTION 1 - Check for restricted vent inlet or exhaust. Remove all blockage. ACTION 2 - Check for proper vent sizing. See installation instructions.</p>
<p align="center">6.2</p> <ul style="list-style-type: none"> - Combustion air blower energizes with a heating demand. - Burners light but fail to stay lit. - After 5 tries the control diagnostics flash the watchdog burners failed to ignite code. <p>LED#1-Alternating Slow Flash LED#2-Alternating Slow Flash</p>	<p align="center">6.2.1</p> <p>Sensor or sense wire is improperly installed.</p>	<p>ACTION 1 - Check that sensor is properly located (page 10) and that the sense wire is properly attached to both the sensor and the control.</p>
	<p align="center">6.2.2</p> <p>Sensor or sense wire is broken.</p>	<p>ACTION 1 - Check for a broken sensor. ACTION 2 - Test continuity across the sense wire. If wire or sensor are damaged replace the component.</p>
	<p align="center">6.2.3</p> <p>Sensor or sensor wire is grounded to the unit.</p>	<p>ACTION 1 - Check for resistance between the sensor rod and the unit ground. ACTION 2 - Check for resistance between the sensor wire and the unit ground. ACTION 3 - Correct any shorts found in circuit.</p>
	<p align="center">6.2.4</p> <p>Control does not sense flame.</p>	<p>ACTION 1 - Check the microamp signal from the burner flame. If the microamp signal is below normal, check the sense rod for proper location or contamination. ACTION 2 - Replace, clean, or relocate flame sense rod. If rod is to be cleaned, use steel wool or replace sensor. DO NOT CLEAN ROD WITH SAND PAPER. SAND PAPER WILL CONTRIBUTE TO THE CONTAMINATION PROBLEM. NOTE: Do not attempt to bend sense rod.</p>

**PROBLEM 6: BURNERS LIGHT WITH HEATING DEMAND BUT UNIT SHUTS DOWN
PREMATURELY (CONT.)**

Condition	Possible Cause	Corrective Action/Comments
<p align="center">6.3</p> <ul style="list-style-type: none"> - Combustion air blower energizes with a heating demand. - Burners light. - Roll-out switch trips during the heating demand. - Diagnostic lights flash roll-out failure. <p>GHR32Q/V-1 through -4 Units Only LED#1-On LED#2-Slow Flash</p> <p>GHR32Q/V-5 Units LED#1-Slow Flash LED#2-On</p>	<p align="center">6.3.1</p> <p align="center">Unit is firing above 100% of the nameplate input.</p>	<p>ACTION 1 - Check that the manifold pressure matches value listed on nameplate. See installation instructions for proper procedure.</p> <p>ACTION 2 - Verify that the installed orifice size match the size listed on the nameplate or installation instructions.</p> <p>ACTION 3 - Check gas valve sensing hose to insure no leaks are present.</p> <p>ACTION 4 - Check the input rate to verify rate matches value listed on nameplate.</p>
	<p align="center">6.3.2</p> <p align="center">Gas orifices leak at the manifold connection.</p>	<p>ACTION 1 - Tighten orifice until leak is sealed. NOTE: Be careful not to strip orifice threads.</p> <p>ACTION 2 - Check for gas leakage at the threaded orifice connection. Use approved method for leak detection (see unit instructions).</p>
	<p align="center">6.3.3</p> <p align="center">Air leakage at the connections between the primary heat exchanger, secondary heat exchanger, and combustion air blower.</p>	<p>ACTION 1 - Check for air leakage at all joints in the heat exchanger assembly. Condition may cause high CO₂ with high CO.</p> <p>ACTION 2 - Seal leakage if possible (high temperature silicon is recommended), replace heat exchanger if necessary, tag and return heat exchanger to proper Lennox personnel.</p>
	<p align="center">6.3.4</p> <p align="center">Insufficient flow through the heat exchanger caused by a sooted or restricted heat exchanger.</p>	<p>ACTION 1 - Check for sooting deposits or other restrictions in the heat exchanger assembly. Clean assembly as outlined in instruction manual.</p> <p>ACTION 2 - For GHR32 gas furnaces, check for proper combustion and flow. CO₂ should measure between 6.0% and 8.0% for NAT and 7.0% and 9.0% for LP. CO should measure below .04% (400PPM) in an air-free sample of flue gases.</p>
	<p align="center">6.3.5</p> <p align="center">Burners are not properly located in the burner box.</p>	<p>ACTION 1 - Check that the burners are firing into the center of the heat exchanger openings. Correct the location of the burners if necessary.</p>
<p align="center">6.4</p> <ul style="list-style-type: none"> - Combustion air blower energizes with a heating demand. - Burners light roughly and the unit fails to stay lit. - Diagnostic lights flash watchguard flame failure. <p>LED#1-Alternating Slow Flash LED#2-Alternating Slow Flash</p>	<p align="center">6.4.1</p> <p align="center">Recirculation of flue gases. This condition causes rough ignitions and operation. Problem is characterized by nuisance flame failures.</p>	<p>ACTION 1 - Check for proper flow of exhaust gases away from intake vent. Remove any obstacles in front of the intake and exhaust vent which would cause recirculation.</p> <p>ACTION 2 - Check for correct intake and exhaust vent installation.</p>
	<p align="center">6.4.2</p> <p align="center">Improper burner cross-overs</p>	<p>ACTION 1 - Remove burner and inspect the cross-overs for burrs, or any restriction or if crossover is warped. Remove restriction or replace burners.</p>

PROBLEM 6: BURNERS LIGHT WITH HEATING DEMAND BUT UNIT SHUTS DOWN PREMATURELY (CONT.)

<p align="center">6.5</p> <ul style="list-style-type: none"> - Combustion air blower energizes with a heating demand. - Burners light. - Diagnostic lights flash watch guard flame failure. - NOTE” Unit might go into 60 minute Watchguard mode depending on intermittent nature of sensor signal. <p>LED#1-Alternating Slow Flash LED#2-Alternating Slow Flash</p>	<p align="center">6.5.1</p> <p>Loose sensor wire connection causes intermittent loss of flame signal.</p>	<p>ACTION 1 - Check that the sensor is properly located.</p> <p>ACTION 2 - Check that the sense wire is properly attached to both the sensor and the control. Pay extra attention to the pin connectors.</p>
---	--	--

PROBLEM 7: CONTROL SIGNALS LOW FLAME SENSE DURING HEATING MODE

Condition	Possible Cause	Corrective Action/Comments
<p align="center">7.0</p> <ul style="list-style-type: none"> - Unit operates correctly but the diagnostic lights flash low flame sense code. <p>LED#1-Slow Flash LED#2-Fast Flash</p>	<p align="center">7.1.1</p> <p>Sense rod is improperly located on the burner.</p>	<p>ACTION 1 - Check the sense rod for proper location on the burner. Properly locate the sense rod or replace if rod cannot be located correctly.</p>
	<p align="center">7.1.2</p> <p>Sense rod is contaminated.</p>	<p>ACTION 1 - Check sense rod for contamination or coated surface. Clean the sense rod with steel wool or replace sensor. DO NOT USE SAND PAPER TO CLEAN ROD. SAND PAPER WILL CONTRIBUTE TO THE CONTAMINATION PROBLEM.</p>

PROBLEM 8: RF STATIC DURING TIME FOR IGNITION

Condition	Possible Cause	Corrective Action/Comments
<p align="center">8.0</p> <ul style="list-style-type: none"> - AM radio interference 	<p align="center">8.1.1</p> <p>Ignitor operation</p>	<p>ACTION 1- Call Technical Support, Dallas</p>

VSP2-1 Blower Control Board GHR32V-1 / -3 Units

COOLING MODE

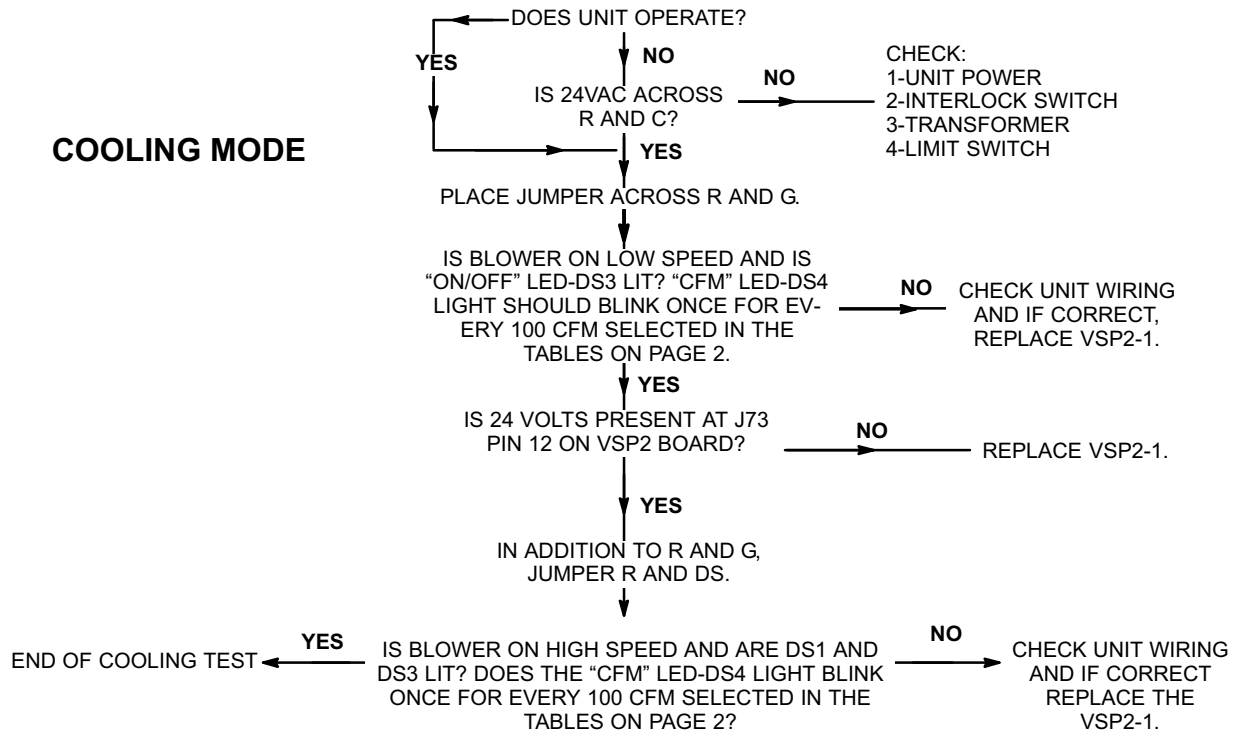

HEATING MODE

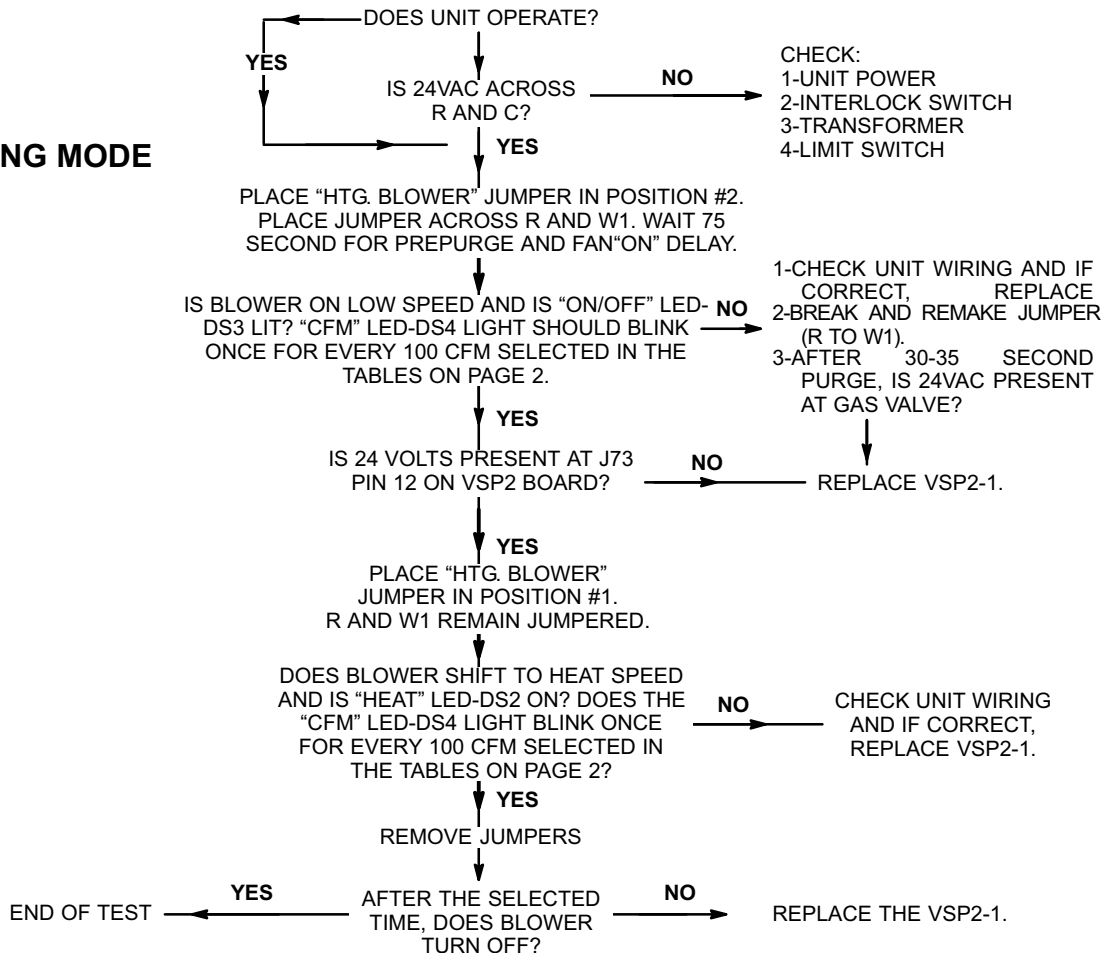

VSP3-1 Blower Control Board GHR32V-4 Units

COOLING MODE

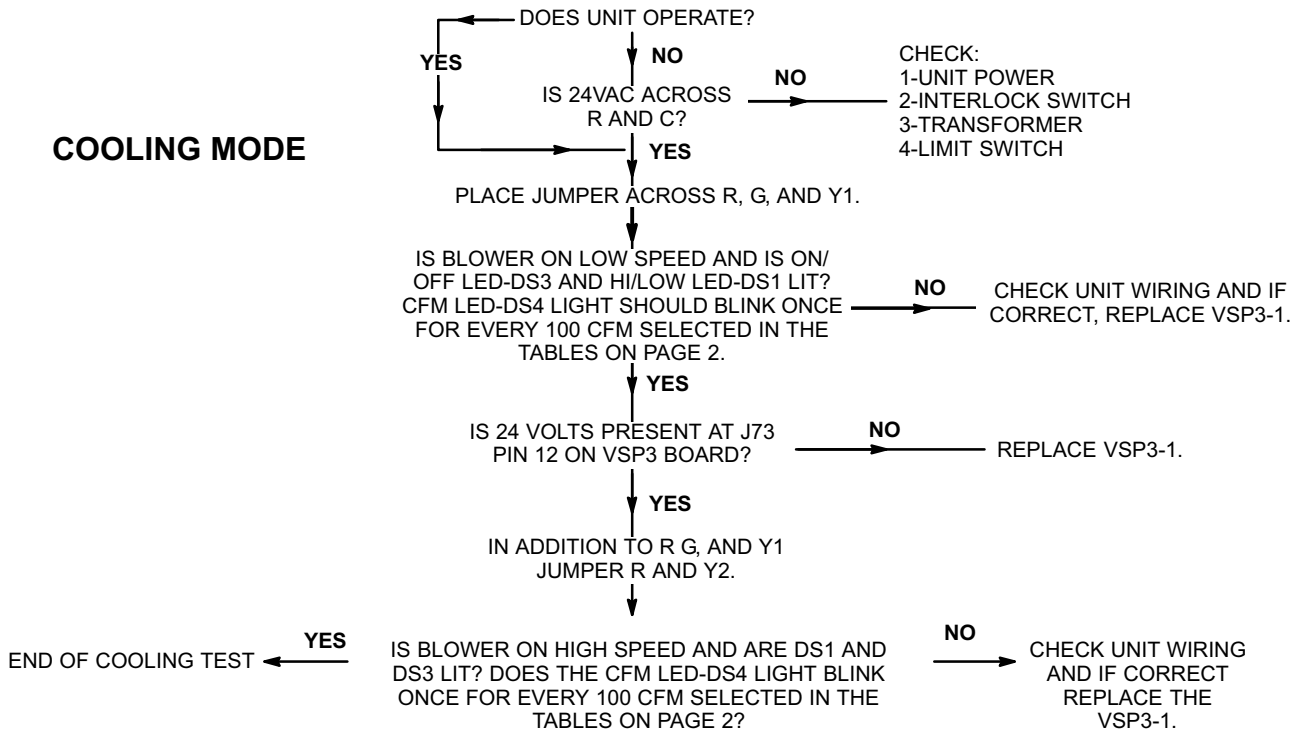

HEATING MODE

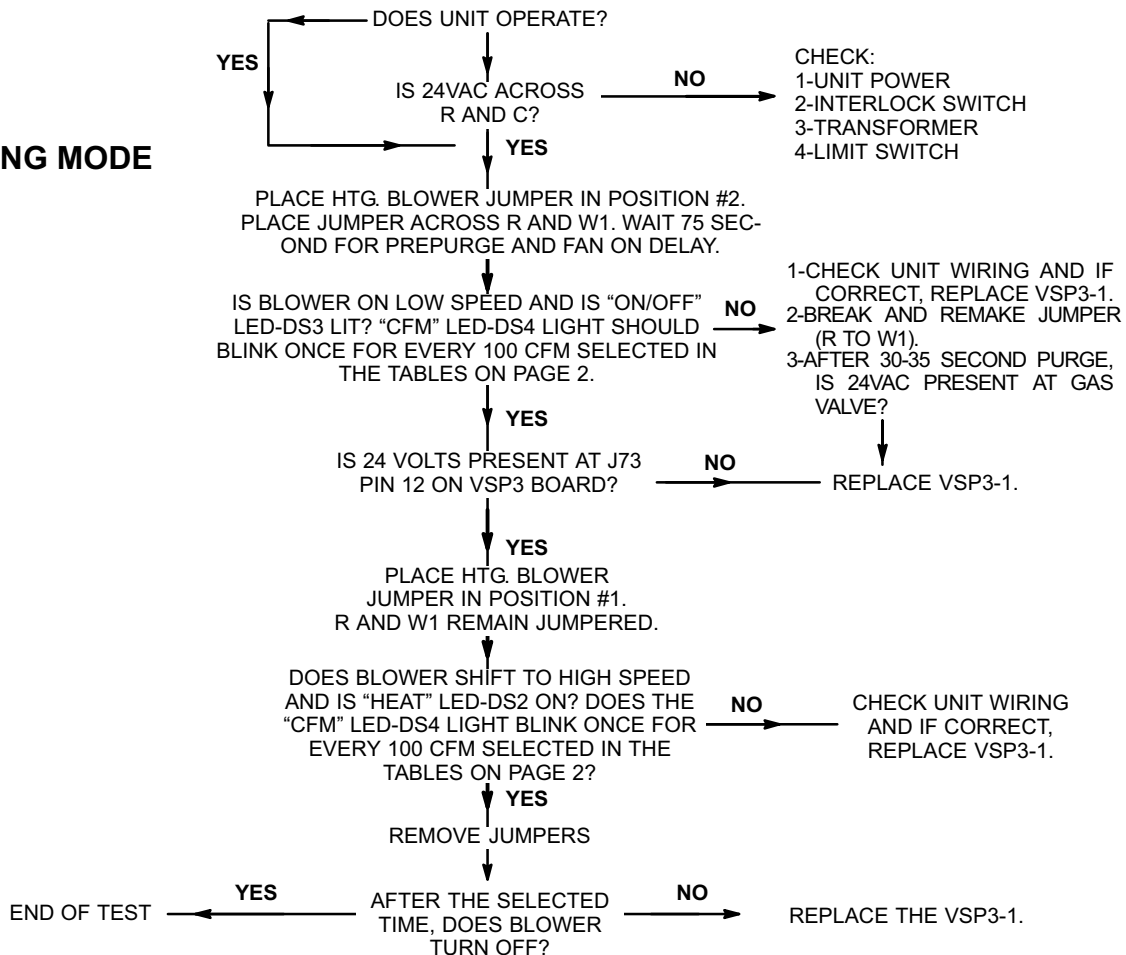

ICM-2 WITH VSP2

120V to the motor must not be interrupted. All connections for check out will be from the voltage source below (battery or 24V) to plug J46, after disconnecting from blower control board VSP2.

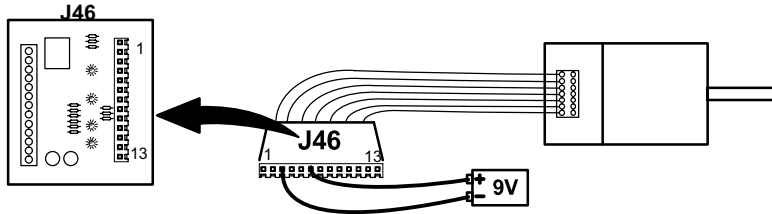

CHECK-OUT PROCEDURE USING BATTERY

An ordinary 9 volt battery with maximum DC 20volts is recommended. A 9 volt battery will last for about one day of normal operation.

CHECK-OUT PROCEDURE USING 24V SOURCE

Unit transformer T1 with a maximum AC 30 volts may be used in lieu of a battery. If transformer T1 is used, double check all wiring connections before placing unit back in operation.

LOW SPEED CHECK-OUT

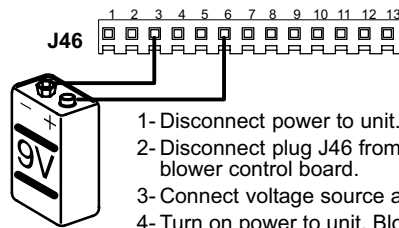

- 1- Disconnect power to unit.
- 2- Disconnect plug J46 from P46 located on the blower control board.
- 3- Connect voltage source as shown above.
- 4- Turn on power to unit. Blower should operate at low speed.

LOW SPEED CHECK-OUT

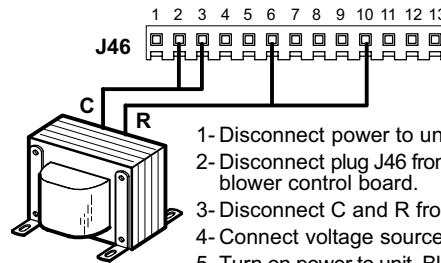

- 1- Disconnect power to unit.
- 2- Disconnect plug J46 from P46 located on the blower control board.
- 3- Disconnect C and R from control board.
- 4- Connect voltage source as shown above.
- 5- Turn on power to unit. Blower should operate at low speed.

HIGH SPEED CHECK-OUT

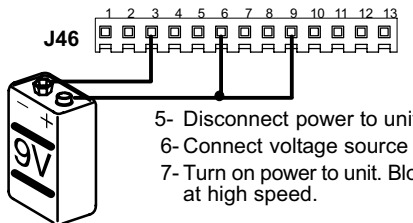

- 5- Disconnect power to unit.
- 6- Connect voltage source as shown above.
- 7- Turn on power to unit. Blower should operate at high speed.

HIGH SPEED CHECK-OUT

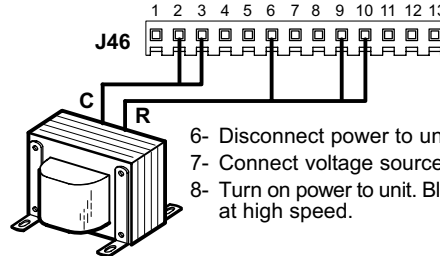

- 6- Disconnect power to unit.
- 7- Connect voltage source as shown above.
- 8- Turn on power to unit. Blower should operate at high speed.

HEATING SPEED CHECK-OUT

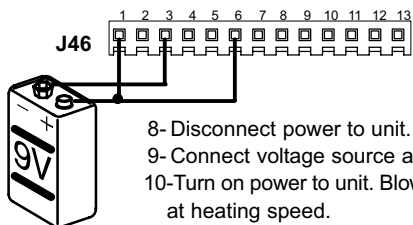

- 8- Disconnect power to unit.
- 9- Connect voltage source as shown above.
- 10- Turn on power to unit. Blower should operate at heating speed.

HEATING SPEED CHECK-OUT

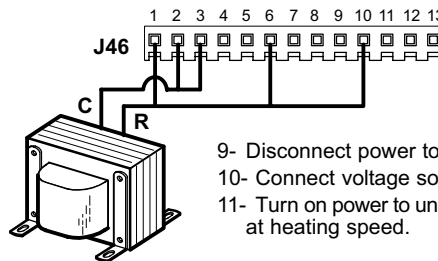

- 9- Disconnect power to unit.
- 10- Connect voltage source as shown above.
- 11- Turn on power to unit. Blower should operate at heating speed.

A kit is available from the Lennox parts center to use in testing the variable speed motor. The kit 70J11 includes a test plug harness to facilitate ICM-2 check-out. **Follow testing procedures outlined in the instructions provided with the kit. The testing procedures are different than those listed above.**

ICM-2 WITH VSP3

120V to the motor must not be interrupted. All connections for check out will be from the voltage source below (battery or 24V) to plug J46, after disconnecting from blower control board.

CHECK-OUT PROCEDURE USING BATTERY

An ordinary 9 volt battery with maximum DC 20volts is recommended. A 9 volt battery will last for about one day of normal operation.

LOW COOL SPEED

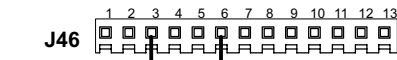

- 1- Disconnect power to unit.
- 2- Disconnect plug J46 from P46 located on the blower control board.
- 3- Connect voltage source as shown above.
- 4- Turn on power to unit. Blower should operate at low cool speed.

HIGH COOL SPEED

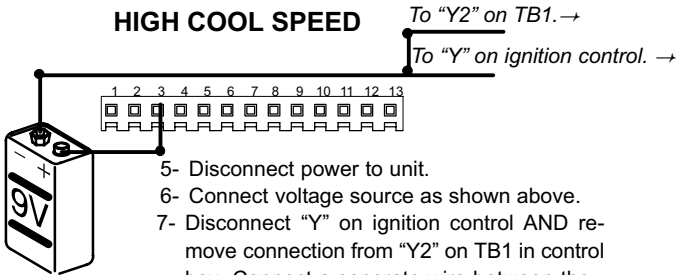

- 5- Disconnect power to unit.
- 6- Connect voltage source as shown above.
- 7- Disconnect "Y" on ignition control AND remove connection from "Y2" on TB1 in control box. Connect a separate wire between the - side of the battery and BOTH "Y" on the ignition control and Y2" on TB1.
- 8- Turn on power to unit. Blower should operate at high cool speed.

LOW HEAT SPEED

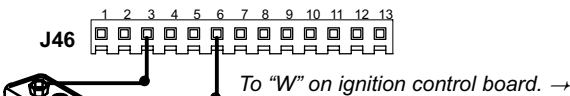

- 9- Disconnect power to unit.
- 10- Connect voltage source as shown above.
- 11- Disconnect "W" terminal on ignition control board and connect a separate wire between "W" and + side of battery.
- 12- Turn on power to unit. Blower should operate at low heat speed.

HIGH HEAT SPEED

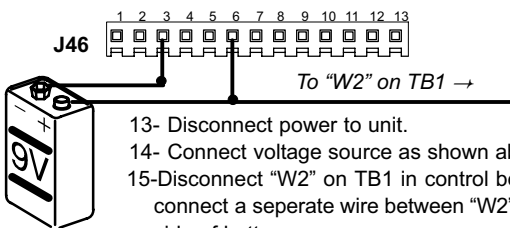

- 13- Disconnect power to unit.
- 14- Connect voltage source as shown above.
- 15- Disconnect "W2" on TB1 in control box and connect a separate wire between "W2" and + side of battery.
- 16- Turn on power to unit. Blower should operate at high heat speed.

CHECK-OUT PROCEDURE USING 24V SOURCE

Unit transformer T1 with a maximum AC 30 volts may be used in lieu of a battery. If transformer T1 is used, double check all wiring connections before placing unit back in operation.

LOW COOL SPEED

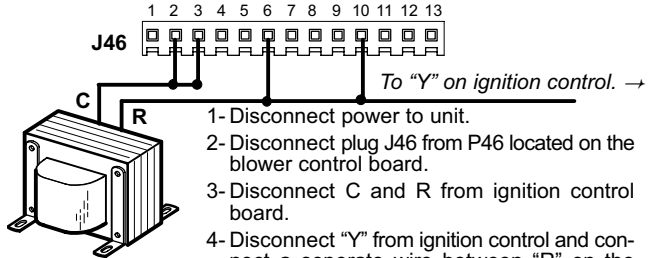

- 1- Disconnect power to unit.
- 2- Disconnect plug J46 from P46 located on the blower control board.
- 3- Disconnect C and R from ignition control board.
- 4- Disconnect "Y" from ignition control and connect a separate wire between "R" on the transformer and "Y" on the ignition control.
- 5- Connect voltage source as shown above.
- 6- Turn on power to unit. Blower should operate at low cool speed.

HIGH COOL SPEED

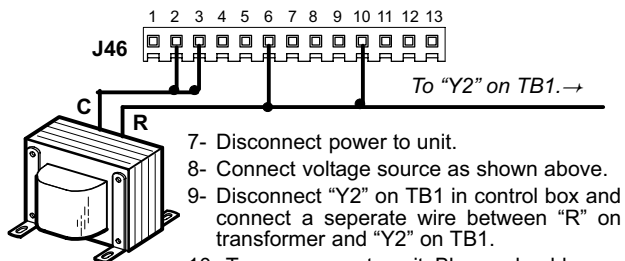

- 7- Disconnect power to unit.
- 8- Connect voltage source as shown above.
- 9- Disconnect "Y2" on TB1 in control box and connect a separate wire between "R" on transformer and "Y2" on TB1.
- 10- Turn on power to unit. Blower should operate at high cool speed.

LOW HEAT SPEED

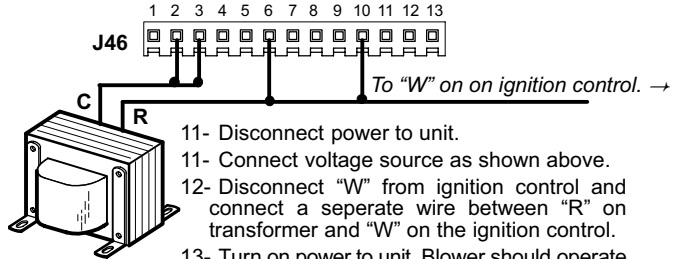

- 11- Disconnect power to unit.
- 11- Connect voltage source as shown above.
- 12- Disconnect "W" from ignition control and connect a separate wire between "R" on transformer and "W" on the ignition control.
- 13- Turn on power to unit. Blower should operate at low heat speed.

HIGH HEAT SPEED

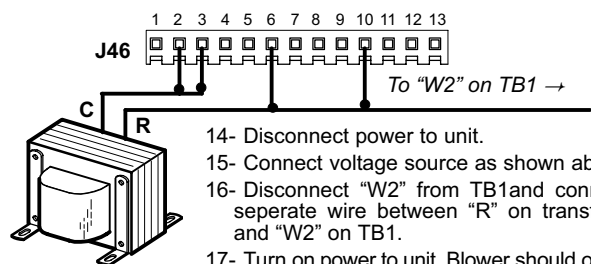

- 14- Disconnect power to unit.
- 15- Connect voltage source as shown above.
- 16- Disconnect "W2" from TB1 and connect a separate wire between "R" on transformer and "W2" on TB1.
- 17- Turn on power to unit. Blower should operate at low heat speed.

ICM-2 WITH TWO STAGE VARIABLE SPEED CONTROL BOARD

120V to the motor must not be interrupted. All connections for check out will be from the voltage source below (battery or 24V) to plug J46, after disconnecting from blower control board.

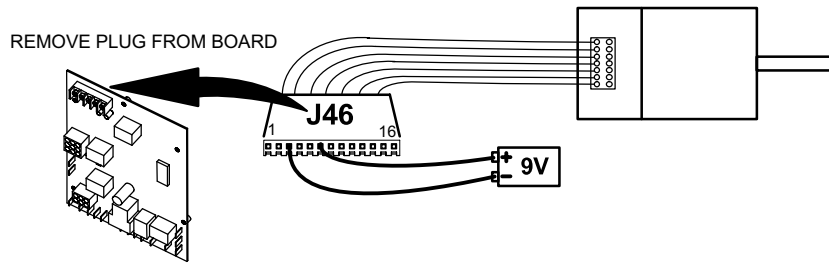

CHECK-OUT PROCEDURE USING BATTERY

An ordinary 9 volt battery with maximum DC 20volts is recommended. A 9 volt battery will last for about one day of normal operation.

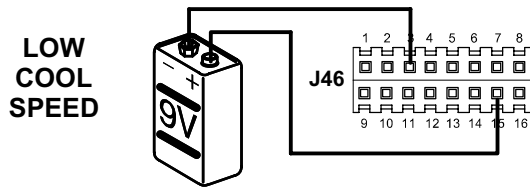

**LOW
COOL
SPEED**

- 1- Disconnect power to unit.
- 2- Disconnect plug J46 from P46 located on the blower control board.
- 3- Connect voltage source as shown above.
- 4- Turn on power to unit. Blower should operate at low cool speed.

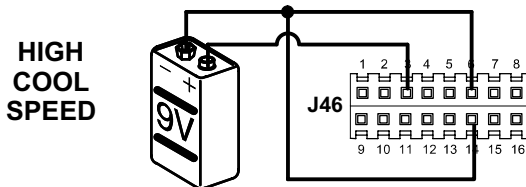

**HIGH
COOL
SPEED**

- 5- Disconnect power to unit.
- 6- Connect voltage source as shown above.
- 7- Turn on power to unit. Blower should operate at high cool speed.

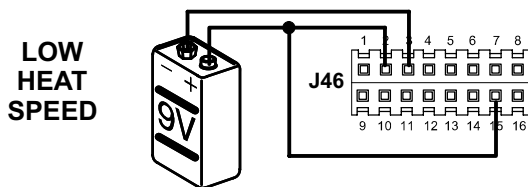

**LOW
HEAT
SPEED**

- 8- Disconnect power to unit.
- 9- Connect voltage source as shown above.
- 10- Turn on power to unit. Blower should operate at low heat speed.

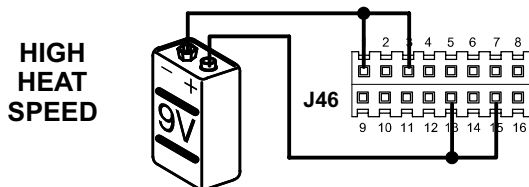

**HIGH
HEAT
SPEED**

- 11- Disconnect power to unit.
- 12- Connect voltage source as shown above.
- 13- Turn on power to unit. Blower should operate at high heat speed.

CHECK-OUT PROCEDURE USING 24V SOURCE

Unit transformer T1 with a maximum AC 30 volts may be used in lieu of a battery. If transformer T1 is used, double check all wiring connections before placing unit back in operation.

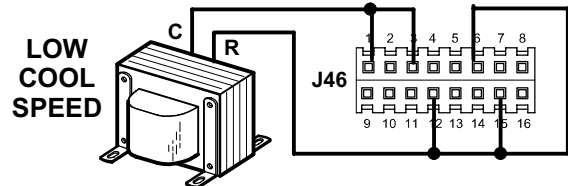

**LOW
COOL
SPEED**

- 1- Disconnect power to unit.
- 2- Disconnect plug J46 from P46 located on the blower control board.
- 3- Connect voltage source as shown above.
- 4- Turn on power to unit. Blower should operate at low cool speed.

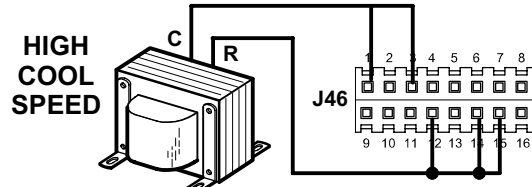

**HIGH
COOL
SPEED**

- 5- Disconnect power to unit.
- 6- Connect voltage source as shown above.
- 7- Turn on power to unit. Blower should operate at high cool speed.

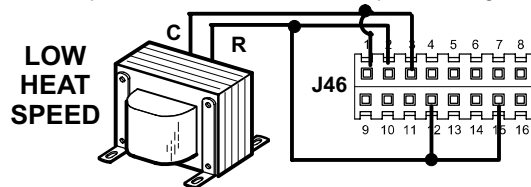

**LOW
HEAT
SPEED**

- 8- Disconnect power to unit.
- 9- Connect voltage source as shown above.
- 10- Turn on power to unit. Blower should operate at low heat speed.

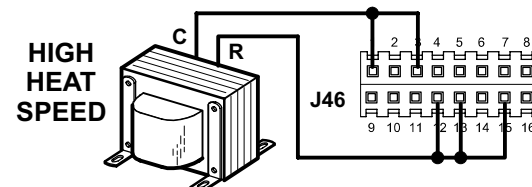

**HIGH
HEAT
SPEED**

- 11- Disconnect power to unit.
- 12- Connect voltage source as shown above.
- 13- Turn on power to unit. Blower should operate at high heat speed.

TABLE 35

GHR32V-1 / -3 UNITS OPERATION SEQUENCE AND JUMPERS SUMMARY WITH VSP2-1 (HEATING)

MATCH UP	T-Strip Jumper	Mode of Operation Jumper	COMMENTS OR SEQUENCE	
<p>FOR COOLING JUMPERS SEE COOLING SECTION BELOW</p> <p>Single-Stage Heating with Single-Stage Thermostat</p>	<p>No Jumpers</p>	<p>One-Stage</p>	<p>Blower operates on the high speed heat tap during the heating mode.</p>	
<p>Two-Stage Heating With Single-Stage Thermostat</p>	<p>No Jumpers</p>	<p>W2 Timed</p>	<p>Blower operates on the low speed heat/cool tap during the first stage of heating. Blower operates on the high speed heat tap during second stage heating.</p>	

Page 88

(continued on following page)

(continued from previous page)

GHR32V-1 / -3 UNITS OPERATION SEQUENCE AND JUMPERS SUMMARY WITH VSP2-1 (HEATING CONTINUED)

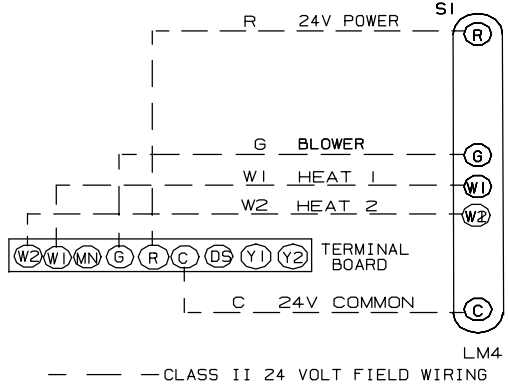
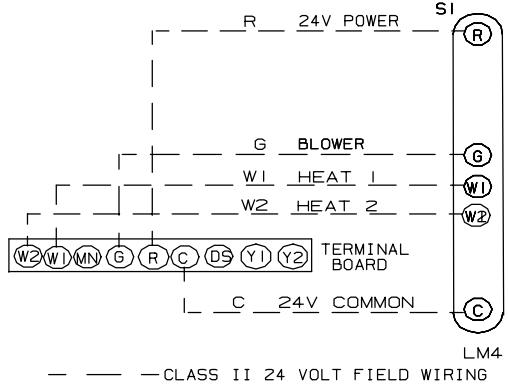
MATCH UP	T-Strip Jumper	Mode of Operation Jumper	COMMENTS OR SEQUENCE	
Two-Stage Heating With Two-Stage Thermostat	No Jumpers	Two-Stage	Blower operates on the low speed heat/cool tap during first stage heating. Blower operates on high speed heat tap during second stage heating.	

GHR32V-1 / -3 UNITS OPERATION SEQUENCE AND JUMPERS SUMMARY WITH VSP2-1 (COOLING)

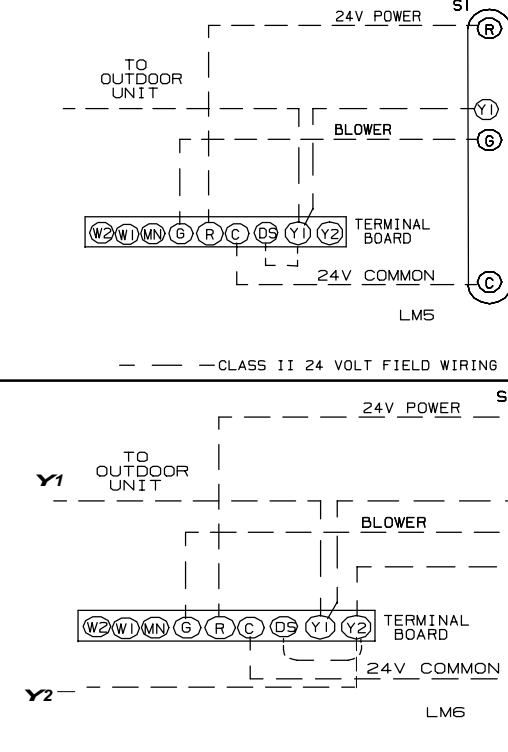
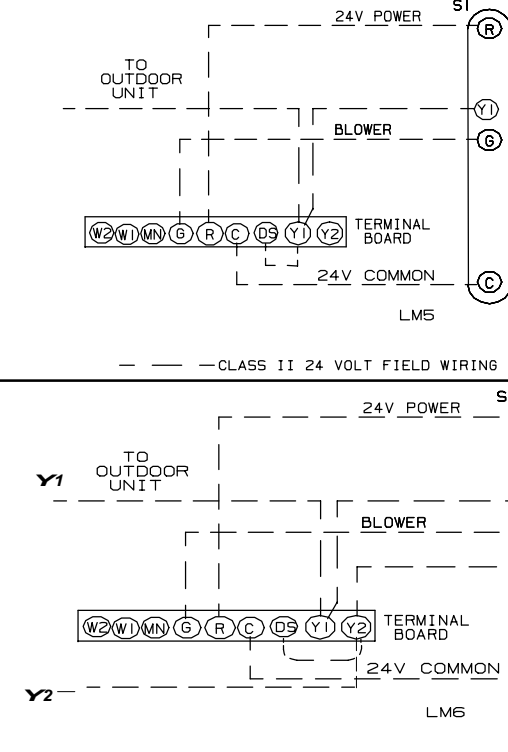
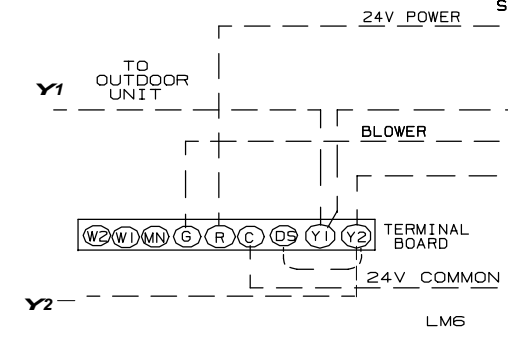
MATCH UP	T-STRIP JUMPER	COMMENTS OR SEQUENCE	
FOR HEATING JUMPERS SEE HEATING SECTION ABOVE Single-Speed Compressor, no CCB1, no Harmony	"DS to "Y1" (factory wired)	Blower operates on high speed cool tap during cooling.	
	Remove Jumper "DS to Y1"	Blower operates on low speed heat/cool during cooling	
Two-Speed Compressor, no CCB1, no Harmony	"DS" to "Y2" Move factory wired jumper from "Y1 to "Y2".	Blower operates on low speed heat/cool tap when compressor is in first stage cooling. Blower operates on high speed cool tap when compressor is in second stage cooling.	

Page 89

(continued on following page)

(continued from previous page)

GHR32V-1 / -3UNITS OPERATION SEQUENCE AND JUMPERS SUMMARY WITH VSP2-1 (COOLING CONTINUED)

MATCH UP	T-STRIP JUMPER	COMMENTS OR SEQUENCE	
<p>FOR HEATING JUMPERS SEE HEATING SECTION ABOVE</p> <p>CCB1 with Single-Speed Compressor, no Harmony</p>	<p>No Jumpers (Remove jumper from "Y1 to "DS")</p>	<p>Blower speed is controlled by the DC signal from CCB1. Blower operates on low speed heat/cool tap during dehumidification. Otherwise, blower operates on high speed cool tap during cooling cycle.</p>	<p>LM7</p> <p>A20 HUMIDITY CONTROL</p> <p>— — — CLASS II 24 VOLT FIELD WIRING</p>
<p>CCB1 with Two-Speed Compressor, no Harmony</p>	<p>No Jumpers (Remove jumper from "Y1 to "DS")</p>	<p>Blower speed is controlled by the DC signal from CCB1. Blower operates on low speed heat/cool tap during dehumidification. Otherwise, blower operates on high speed cool tap during high speed compressor operation and low speed heat/cool tap during low speed compressor operation.</p>	<p>LMB</p> <p>A20 HUMIDITY CONTROL</p> <p>— — — CLASS II 24 VOLT FIELD WIRING</p>

Page 90

(continued on following page)

(continued from previous page)

GHR32V-1 / -3 UNITS OPERATION SEQUENCE AND JUMPERS SUMMARY WITH VSP2-1 (COOLING CONTINUED)

MATCH UP	T-STRIP JUMPER	COMMENTS OR SEQUENCE	WIRING CONNECTIONS
<p>FOR HEATING JUMPERS SEE SEE HEATING SECTION ABOVE</p> <p>Harmony and Single-Speed Compressor</p>	<p>No Jumpers (Remove jumper from "Y1 to "DS").</p>	<p>Remove pin #3 of the J73 terminal on the VSP control. Insulate end to prevent shorting. Blower operates on PWM signal generated by Harmony. Harmony overrides blower speed taps. Blower speed varies according to zone demand.</p>	
<p>Harmony and Two-Speed Compressor</p>	<p>No Jumpers (Remove jumper from "Y1 to "DS").</p>	<p>Remove pin #3 of the J73 terminal on the VSP control. Insulate end to prevent shorting. Blower operates on PWM signal generated by Harmony. Harmony overrides blower speed taps. Blower speed varies according to zone demand.</p>	

**TABLE 36
GHR32V-4 OPERATION SEQUENCE AND JUMPERS SUMMARY WITH VSP3-1 (HEATING)**

MATCH UP	T-Strip Jumper	Mode of Operation Jumper	COMMENTS OR SEQUENCE	WIRING CONNECTIONS
<p>FOR COOLING JUMPERS SEE COOLING SECTION BELOW</p> <p>Single-Stage Heating with Single-Stage Thermostat</p>	No Jumpers	One-Stage	Blower operates on high speed during the heating mode.	
<p>Two-Stage Heating With Single-Stage Thermostat</p>	No Jumpers	W2 Timed	Blower operates on low speed during the first stage of heating. Blower operates on high speed during second-stage heating.	
<p>Harmony Heating</p>	No Jumpers	Two-Stage	<p>Remove pin #3 of the J73 plug on the VSP control, and pins #2 and 13 of the J49 plug at the motor. See fig 19 and 39. Insulate ends to prevent them from shorting.</p> <p>Blower operates on PWM signal generated by Harmony. Harmony overrides blower speed taps. Blower speed varies according to zone demand.</p> <p>Low and high fire controlled by temperature modulating switch.</p>	

Page 92

(continued on following page)

(continued from previous page)

GHR32V-4 OPERATION SEQUENCE AND JUMPERS SUMMARY WITH VSP3-1 (HEATING CONTINUED)

MATCH UP	T-Strip Jumper	Mode of Operation Jumper	COMMENTS OR SEQUENCE	WIRING CONNECTIONS
Two-Stage Heating With Two-Stage Thermostat	No Jumpers	Two-Stage	Blower operates on low speed during first stage heating. Blower operates on high speed during second stage heating.	

GHR32V-4 OPERATION SEQUENCE AND JUMPERS SUMMARY WITH VSP3-1 (COOLING)

MATCH UP	T-STRIP JUMPER	COMMENTS OR SEQUENCE	WIRING CONNECTIONS
FOR HEATING JUMPERS SEE HEATING SECTION ABOVE Single-Speed Compressor, no CCB1, no Harmony	DS to Y1 and Y1 to Y2 and O to R (factory wired)	Blower operates on high speed during cooling.	
	Remove jumper DS to Y1	Blower operates on low speed during cooling.	
Two-Speed Compressor, no CCB1, no Harmony	DS to Y1 and O to R Remove factory-wired jumper Y1 to Y2.	Blower operates on low speed cool when compressor is in first stage cooling. Blower operates on high speed cool when compressor is in second stage cooling.	

Page 93

(continued on following page)

(continued from previous page)

GHR32V-4 OPERATION SEQUENCE AND JUMPERS SUMMARY WITH VSP3-1 (COOLING CONTINUED)

MATCH UP	T-STRIP JUMPER	COMMENTS OR SEQUENCE	WIRING CONNECTIONS
<p>FOR HEATING JUMPERS SEE HEATING SECTION ABOVE</p> <p>CCB1 with Single-Speed Compressor, no Harmony</p>	<p>Y1 to Y2 and O to R Remove the factory-wired jumper Y1 to DS.</p>	<p>Blower speed is controlled by the DC signal from CCB1. Blower operates on low speed during dehumidification. Otherwise, blower operates on high speed during cooling cycle.</p>	<p style="text-align: center;">WIRING CONNECTIONS</p> <p style="text-align: center;">LM7 --- CLASS II 24 VOLT FIELD WIRING</p>
<p>CCB1 with Two-Speed Compressor, no Harmony</p>	<p>O to R Remove jumper from Y1 to DS and Y1 to Y2.</p>	<p>See table 9.</p>	<p style="text-align: center;">LMB --- CLASS II 24 VOLT FIELD WIRING</p>

Page 94

(continued on following page)

(continued from previous page)

GHR32V-4 OPERATION SEQUENCE AND JUMPERS SUMMARY WITH VSP3-1 (COOLING CONTINUED)

MATCH UP	T-STRIP JUMPER	COMMENTS OR SEQUENCE	WIRING CONNECTIONS
<p>FOR HEATING JUMPERS SEE SEE HEATING SECTION ABOVE</p> <p>Harmony and Single-Speed Compressor</p>	<p>Y1 to Y2 and O to R (Remove jumper from Y1 to DS.)</p>	<p>Remove the wire from Pin #2 and Pin #13 of the J49 harness connector at the motor and the wire from Pin #3 of the J73 harness connector on the VSP control board.</p> <p>Insulate the wire ends and secure them to prevent shorting. Blower operates on PWM signal generated by the Harmony control board control board. The Harmony control board overrides blower speed taps. Blower speed varies according to the zone's demand.</p>	<p>WIRING CONNECTIONS</p>
<p>Harmony and Two-Speed Compressor</p>	<p>O to R (Remove jumper from Y1 to DS and Y1 to Y2.)</p>	<p>Remove the wire from Pin #2 and Pin #13 of the J49 harness connector at the motor and the wire from Pin #3 of the J73 harness connector on the VSP control board.</p> <p>Insulate the wire ends and secure them to prevent shorting. Blower operates on PWM signal generated by the Harmony control board. The Harmony control board overrides blower speed taps. Blower speed varies according to zone's demand.</p>	

Table 37
GHR32V-5 Units Field Wiring Applications

Thermostat	Jumper Settings (See figure 21)				Wiring Connections
	E20	Term. Strip Y1 to Y2	W914	W951	
1 Heat / 1 Cool <i>NOTE - Use dip switch 3 to set second-stage heat ON delay. ON-10 minutes. OFF-15 minutes.</i>	SINGLE	Yes	Intact	Intact	
1 Heat / 1 Cool with CCB1 <i>NOTE - Use dip switch 3 to set second-stage heat ON delay. ON-10 minutes. OFF-15 minutes.</i>	SINGLE	Yes	Cut	Intact	

Table 37
GHR32V-5 Units Field Wiring Applications (Continued)

Thermostat	Jumper Settings (See figure 21)				Wiring Connections
	E20	Term. Strip Y1 to Y2	W914	W951	
1 Heat / 2 Cool <i>NOTE - Use dip switch 3 to set second-stage heat ON delay. ON-10 minutes. OFF-15 minutes.</i>	SINGLE	No	Intact	Intact	
1 Heat / 2 Cool with CCB1 <i>NOTE - Use dip switch 3 to set second-stage heat ON delay. ON-10 minutes. OFF-15 minutes.</i>	SINGLE	No	Cut	Intact	
2 Heat / 2 Cool	TWO	No	Intact	Intact	
2 Heat / 2 Cool with CCB1	TWO	No	Cut	Intact	

Table 37
GHR32V-5 Units Field Wiring Applications (Continued)

Thermostat	Jumper Settings (See figure 21)				Wiring Connections
	E20	Term. Strip Y1 to Y2	W914	W951	
2 Heat / 1 Cool	TWO	Yes	Intact	Intact	
FM21 Heat Pump / 1 Cool	SINGLE	Yes	Intact	Cut	<p align="center">CONTROL TERM. STRIP FM21</p> <p>*Disconnect existing furnace transformer and replace with 75VA, 24V transformer if de-frost option to be used.</p> <p align="center">75VA, 24V TRANSFORMER*</p> <p>NOTE - Wiring connections to outdoor unit and thermostat made at FM21 control board per FM21 instructions.</p> <p>NOTE - Remove Y1/Y2 jumper for two-stage cooling.</p>
Harmony Application* 2 Heat / 1 Cool	TWO	Yes	Cut	Intact	
Harmony Application* 2 Heat / 2 Cool	TWO	No	Cut	Intact	

*Cut wires at pin positions 2 and 13 of J/P46. Insulate ends to prevent a short. Blower operates on PWM signal generated by Harmony. Harmony overrides blower speed taps. Blower speed varies according to zone demand. Low and high-fire controlled by temperature modulating switch.

SERVICE NOTES