

G60DF(X) SERIES UNITS

G60DF series units are mid-efficiency gas furnaces used for downflow applications only, manufactured with Lennox Duralok Plus heat exchangers formed of aluminized steel. Units are available in heating capacities of 44,000 to 132,000 Btuh and cooling applications up to 5 tons. Refer to Engineering Handbook for proper sizing.

Units are factory equipped for use with natural gas. Kits are available for conversion to LPG operation. G60DF model units are equipped with the Lennox two-stage integrated SureLight control. G60DF units meets the California Nitrogen Oxides (NO_x) Standards and California Seasonal Efficiency requirements. All units use a redundant gas valve to assure safety shut-off as required by C.S.A.

All specifications in this manual are subject to change. Procedures outlined in this manual are presented as a recommendation only and do not supersede or replace local or state codes. In the absence of local or state codes, the guidelines and procedures outlined in this manual (except where noted) are recommendations only and do not constitute code.

TABLE OF CONTENTS

Specifications	Page 2
Blower Data	Page 4
High Altitude	Page 8
Parts Identification	Page 9
I Unit Components	Page 10
II Installation	Page 23
III Start Up	Page 23
IV Heating System Service Checks	Page 24
V Typical Operating Characteristics	Page 26
VI Maintenance	Page 27
VII Wiring and Sequence of Operation	Page 30
VIII Field Wiring and Jumper Settings	Page 46
IX Control Board Troubleshooting	Page 50



G60DF-1 MODEL SHOWN

! IMPORTANT

Improper installation, adjustment, alteration, service or maintenance can cause property damage, personal injury or loss of life. Installation and service must be performed by a qualified installer, service agency or the gas supplier.

! WARNING



Electric shock hazard. Can cause injury or death. Before attempting to perform any service or maintenance, turn the electrical power to unit OFF at disconnect switch(es). Unit may have multiple power supplies.

! WARNING

Sharp edges. Be careful when servicing unit to avoid sharp edges which may result in personal injury.

SPECIFICATIONS G60DF(X) Models

Gas Heating Performance	Model No.	G60DF-24A-045	G60DF-36A-070	G60DF-36B-090	G60DF-48C-090
	Low NO _x Model No.	G60DF-24A-045X	G60DF-36A-070X	- - -	G60DF-48C-090X
Input - Btuh (kW) low fire		30,000 (8.8)	45,000 (13.2)	60,000 (17.6)	60,000 (17.6)
Output - Btuh (kW) low fire		24,000 (7.0)	36,000 (10.5)	48,000 (14.1)	49,000 (14.4)
Input - Btuh (kW) high fire		44,000 (12.8)	66,000 (19.3)	88,000 (25.8)	88,000 (25.8)
Output - Btuh (kW) high fire		36,000 (10.5)	54,000 (15.8)	72,000 (21.1)	72,000 (21.1)
☆AFUE		80.0%	80.0%	80.0%	80.0%
California Seasonal Efficiency		73.3%	74.5%	75.0%	74.4%
High static - in. w.g. (Pa)		.50 (124)	.50 (124)	.50 (124)	.50 (124)
Temperature rise range - °F (°C) low fire		15 - 45 (8 - 25)	-1, -2, units 20 - 50 (11 - 28) -4 units 15 - 45 (6 - 25)	-1, -2, units 25 - 55 (14 - 31) -4 units 20 - 50 (11 - 28)	20 - 50 (11 - 28)
Temperature rise range - °F (°C) high fire		30 - 60 (17 - 33)	35 - 65 (19 - 36)	45 - 75 (25 - 42)	35 - 65 (19 - 36)
Connections	Gas pipe size IPS - in. (mm)	1/2 (12.7)	1/2 (12.7)	1/2 (12.7)	1/2 (12.7)
	Flue connection - in. (mm) round	4 (102)	4 (102)	4 (102)	4 (102)
Indoor Blower	Wheel nominal diameter x width - in.	10 x 8	10 x 8	10 x 8	10 x 10
	mm	254 x 203	254 x 203	254 x 203	254 x 254
	Motor output - hp (W)	1/5 (149)	1/3 (249)	1/3 (249)	1/2 (373)
	Tons (kW) of add-on cooling	1.5 - 2 (5.3 - 7.0)	1.5 - 3 (5.3 - 10.6)	1.5 - 3 (5.3 - 10.6)	2 - 4 (7.0 - 14.1)
Shipping weight - 1 package		121 lbs. (55 kg)	132 lbs. (60 kg)	146 lbs. (66 kg)	153 (69)
Matching Coils		CR26-18N-F, CR26-30N-F, CR26-36N-F	CR26-18N-F, CR26-30N-F, CR26-36N-F	CR26-36W-F, CR26-48N-F	CR26-36W-F, CR26-48N-F, CR26-60N-F
Electrical characteristics		120 volts - 60 hertz - 1 phase (less than 12 amps)			
OPTIONAL ACCESSORIES – MUST BE ORDERED EXTRA					
Down-Flow Additive Base - Shipping Weight - lbs. (kg)		11M59 - 9 (4)	11M59 - 9 (4)	11M60 - 10 (5)	11M61 - 11 (5)
High Altitude		See Page 8			
Propane/Natural Gas Kit 0 to 7500 ft. (0 to 2286 m)		59M87			

☆Annual Fuel Utilization Efficiency based on DOE test procedures and according to FTC labeling regulations. Isolated combustion system rating for non-weatherized furnaces.
NOTE - Filters and provisions for mounting are not furnished and must be field provided.

SPECIFICATIONS Cont.

Gas Heating Performance	Model No. Low NO_x Model No.	G60DF-48C-110 - - - -	G60DF-60C-110 G60DF-60C-110X	G60DF-60D-135 - - - -
	Input - Btuh (kW) low fire	75,000 (22.0)	75,000 (22.0)	90,000 (26.4)
	Output - Btuh (kW) low fire	61,000 (17.9)	61,000 (17.9)	73,000 (21.4)
	Input - Btuh (kW) high fire	110,000 (32.2)	110,000 (32.2)	132,000 (38.7)
	Output - Btuh (kW) high fire	90,000 (26.4)	91,000 (26.7)	109,000 (31.9)
	☆AFUE	80.0%	80.0%	80.0%
	California Seasonal Efficiency	75.4%	74.6%	75.3%
	High static - in. w.g. (Pa)	.50 (124)	.50 (124)	.50 (124)
	Temperature rise range - °F (°C) low fire	-1, -2 units 25 - 55 (14 - 31) -4 units 20 - 50 (11 - 28)	20 - 50 (11 - 28)	25 - 55 (14 - 31)
	Temperature rise range - °F (°C) high fire	45 - 75 (25 - 42)	30 - 60 (17 - 33)	40 - 70 (22 - 39)
Connections	Gas pipe size IPS - in. (mm)	1/2 (12.7)	1/2 (12.7)	1/2 (12.7)
	Flue connection - in. (mm) round	4 (102)	4 (102)	4 (102)
Indoor Blower	Wheel nominal diameter x width - in. mm	10 x 10 254 x 254	11-1/2 x 10 292 x 254	11-1/2 x 10 292 x 254
	Motor output - hp (W)	1/2 (373)	3/4 (560)	3/4 (560)
	Tons (kW) of add-on cooling	2 - 4 (7.0 - 14.1)	4 - 5 (14.1 - 17.6)	4 - 5 (14.1 - 17.6)
Shipping weight - 1 package		169 lbs. (77 kg)	169 lbs. (77 kg)	192 lbs. (87 kg)
Matching Coils		CR26-36W-F, CR26-48N-F, CR26-60N-F	CR26-48N-F, CR26-60N-F	CR26-48W-F, CR26-60W-F
Electrical characteristics		120 volts - 60 hertz - 1 phase (less than 12 amps)		
OPTIONAL ACCESSORIES - MUST BE ORDERED EXTRA				
Down-Flow Additive Base - Shipping Weight - lbs. (kg)		11M61 - 11 (5)	11M61 - 11 (5)	11M62 - 13 (6)
High Altitude		See Page 8		
Propane/Natural Gas Kit	0 to 7500 ft. (0 to 2286 m)	59M87		

☆Annual Fuel Utilization Efficiency based on DOE test procedures and according to FTC labeling regulations. Isolated combustion system rating for non-weatherized furnaces.
NOTE - Filters and provisions for mounting are not furnished and must be field provided.

SPECIFICATIONS Cont.

Gas Heating Performance	Model No.	G60DF-60C-110	G60DF-60D-135
	Low NO_x Model No.	G60DF-60C-110X	----
	Input - Btuh (kW) low fire	75,000 (22.0)	90,000 (26.4)
	Output - Btuh (kW) low fire	61,000 (17.9)	73,000 (21.4)
	Input - Btuh (kW) high fire	110,000 (32.2)	132,000 (38.7)
	Output - Btuh (kW) high fire	91,000 (26.7)	109,000 (31.9)
	☆AFUE	80.0%	80.0%
	California Seasonal Efficiency	74.6%	75.3%
	High static - in. w.g. (Pa)	.50 (124)	.50 (124)
	Temperature rise range - °F (°C) low fire	20 - 50 (11 - 28)	25 - 55 (14 - 31)
Temperature rise range - °F (°C) high fire	30 - 60 (17 - 33)	40 - 70 (22 - 39)	
Connections	Gas pipe size IPS - in. (mm)	1/2 (12.7)	1/2 (12.7)
	Flue connection - in. (mm) round	4 (102)	4 (102)
Indoor Blower	Wheel nominal diameter x width - in.	11-1/2 x 10	11-1/2 x 10
	mm	292 x 254	292 x 254
	Motor output - hp (W)	1 (746) -1, -2 models 3/4 (560)	1 (746) -1, -2 models 3/4 (560)
	Tons (kW) of add-on cooling	4 - 5 (14.1 - 17.6)	4 - 5 (14.1 - 17.6)
Shipping weight - 1 package		172 lbs. (78 kg)	195 lbs. (88 kg)
Matching Coils		CR26-48N-F, CR26-60N-F	CR26-48W-F, CR26-60W-F
Electrical characteristics		120 volts - 60 hertz - 1 phase (less than 12 amps)	
OPTIONAL ACCESSORIES – MUST BE ORDERED EXTRA			
Down-Flow Additive Base - Shipping Weight - lbs. (kg)		11M61 - 11 (5)	11M62 - 13 (6)
High Altitude		See Page 8	
Propane/Natural Gas Kit 0 to 7500ft (0 - 2286m)		59M87	

☆Annual Fuel Utilization Efficiency based on DOE test procedures and according to FTC labeling regulations. Isolated combustion system rating for non-weatherized furnaces.
NOTE - Filters and provisions for mounting are not furnished and must be field provided.

BLOWER DATA

G60DF-24A-045 PERFORMANCE										
External Static Pressure		Air Volume / Watts at Different Blower Speeds								
		High			Medium			Low		
in. w.g.	Pa	cfm	L/s	Watts	cfm	L/s	Watts	cfm	L/s	Watts
0.00	0	1202	565	417	1058	500	367	828	390	278
0.05	12	1185	560	410	1041	490	360	819	385	274
0.10	25	1167	550	402	1024	482	353	809	380	270
0.15	37	1147	540	396	1008	475	346	793	375	265
0.20	50	1127	530	390	991	470	338	776	365	260
0.25	62	1104	520	382	979	460	335	764	360	257
0.30	75	1081	510	374	966	455	331	752	355	254
0.40	100	1018	480	357	922	435	319	712	335	244
0.50	125	960	455	342	873	410	306	651	305	234
0.60	150	901	425	330	811	385	290	618	290	231
0.70	175	815	385	313	691	325	272	564	265	221
0.80	200	685	325	289	619	290	259	465	220	203
0.90	225	558	265	271	510	240	238	395	185	190

NOTE - All air data is measured external to unit with 1 in. (25 mm) cleanable filter (not furnished - field provided) in place. Also see Filter Air Resistance table.

BLOWER DATA Cont.

G60DF-36A-070 PERFORMANCE													
External Static Pressure		Air Volume / Watts at Different Blower Speeds											
		High			Medium-High			Medium-Low			Low		
in. w.g.	Pa	cfm	L/s	Watts	cfm	L/s	Watts	cfm	L/s	Watts	cfm	L/s	Watts
0.00	0	1475	695	616	1343	635	554	1151	545	495	989	465	415
0.05	12	1449	685	606	1321	625	543	1139	540	481	983	465	407
0.10	25	1423	670	595	1298	615	532	1127	530	466	976	460	398
0.15	37	1397	660	585	1276	600	521	1115	525	452	970	460	390
0.20	50	1371	645	574	1253	590	510	1103	520	437	963	455	381
0.25	62	1345	635	563	1228	580	494	1090	515	428	953	450	371
0.30	75	1318	620	552	1203	570	478	1077	510	418	943	445	360
0.40	100	1249	590	528	1151	545	455	1039	490	395	918	435	346
0.50	125	1200	565	508	1094	515	432	998	470	374	882	415	331
0.60	150	1112	525	475	1033	490	409	951	450	354	831	390	313
0.70	175	1032	485	455	968	455	390	856	405	338	722	340	280
0.80	200	959	455	434	876	415	359	737	350	299	666	315	266
0.90	225	770	365	389	715	335	321	667	315	278	591	280	244

NOTE - All air data is measured external to unit with 1 in. (25 mm) cleanable filter (not furnished - field provided) in place. Also see Filter Air Resistance table.

G60DF-36B-090 PERFORMANCE													
External Static Pressure		Air Volume / Watts at Different Blower Speeds											
		High			Medium-High			Medium-Low			Low		
in. w.g.	Pa	cfm	L/s	Watts	cfm	L/s	Watts	cfm	L/s	Watts	cfm	L/s	Watts
0.00	0	1598	755	608	1408	665	526	1166	550	436	963	455	355
0.05	12	1579	745	599	1398	660	518	1164	550	428	966	455	351
0.10	25	1559	735	589	1388	655	509	1161	550	420	968	455	346
0.15	37	1528	720	573	1369	645	497	1156	545	413	966	455	341
0.20	50	1497	705	556	1350	635	485	1150	545	406	964	455	335
0.25	62	1465	690	544	1326	625	473	1137	535	398	955	450	329
0.30	75	1432	675	532	1301	615	460	1124	530	389	945	445	323
0.40	100	1370	645	509	1248	590	438	1093	515	373	933	440	313
0.50	125	1294	610	482	1198	565	420	1055	500	355	902	425	302
0.60	150	1213	575	456	1141	540	397	1012	480	343	862	405	285
0.70	175	1139	540	437	1054	495	371	917	435	313	802	380	272
0.80	200	1002	475	401	948	445	342	850	400	295	728	345	251
0.90	225	901	425	374	822	390	313	740	350	272	---	---	---

NOTE - All air data is measured external to unit with 1 in. (25 mm) cleanable filter (not furnished - field provided) in place. Also see Filter Air Resistance table.

BLOWER DATA Cont.

G60DF-48C-090 PERFORMANCE													
External Static Pressure		Air Volume / Watts at Different Blower Speeds											
		High			Medium-High			Medium-Low			Low		
in. w.g.	Pa	cfm	L/s	Watts	cfm	L/s	Watts	cfm	L/s	Watts	cfm	L/s	Watts
0.00	0	2039	960	749	1852	875	657	1595	755	562	1325	625	466
0.05	12	1998	945	727	1826	860	638	1576	745	547	1338	632	460
0.10	25	1956	925	704	1800	850	619	1556	735	532	1351	640	453
0.15	37	1921	905	692	1770	835	602	1541	725	518	1340	630	441
0.20	50	1885	890	679	1739	820	585	1526	720	503	1329	625	428
0.25	62	1844	870	662	1701	805	568	1502	710	488	1301	615	414
0.30	75	1802	850	645	1663	785	551	1477	695	473	1272	600	399
0.40	100	1693	800	606	1583	745	517	1415	670	448	1226	580	378
0.50	125	1600	755	570	1491	705	485	1334	630	414	1170	550	360
0.60	150	1494	705	540	1406	665	457	1248	590	389	1110	525	337
0.70	175	1378	650	509	1300	615	426	1166	550	367	1026	485	316
0.80	200	1248	590	478	1161	550	390	1027	485	331	---	---	---
0.90	225	1097	520	439	1028	485	360	925	435	307	---	---	---

NOTE - All air data is measured external to unit with 1 in. (25 mm) cleanable filter (not furnished - field provided) in place. Also see Filter Air Resistance table.

G60DF-48C-110 PERFORMANCE													
External Static Pressure		Air Volume / Watts at Different Blower Speeds											
		High			Medium-High			Medium-Low			Low		
in. w.g.	Pa	cfm	L/s	Watts	cfm	L/s	Watts	cfm	L/s	Watts	cfm	L/s	Watts
0.00	0	2034	960	846	1790	845	712	1508	710	595	1226	580	477
0.05	12	2001	945	825	1761	830	694	1493	705	581	1224	580	470
0.10	25	1968	930	803	1731	815	675	1477	695	567	1222	575	463
0.15	37	1924	910	781	1708	805	657	1470	695	555	1219	575	455
0.20	50	1879	885	758	1685	795	638	1463	690	542	1216	575	447
0.25	62	1837	865	736	1654	780	618	1442	680	528	1201	565	437
0.30	75	1794	845	714	1623	765	597	1420	670	514	1186	560	427
0.40	100	1681	795	669	1548	730	564	1361	640	483	1134	535	400
0.50	125	1622	765	630	1445	680	524	1280	605	447	1065	505	371
0.60	150	1447	685	592	1312	620	479	1165	550	404	1000	470	343
0.70	175	1289	610	545	1178	555	434	1056	500	369	907	430	319
0.80	200	1157	545	502	1067	505	406	956	450	348	816	385	296
0.90	225	1012	480	472	931	440	372	840	395	320	690	325	265

NOTE - All air data is measured external to unit with 1 in. (25 mm) cleanable filter (not furnished - field provided) in place. Also see Filter Air Resistance table.

G60DF-60C-110 with 3/4 hp PERFORMANCE													
External Static Pressure		Air Volume / Watts at Different Blower Speeds											
		High			Medium-High			Medium-Low			Low		
in. w.g.	Pa	cfm	L/s	Watts	cfm	L/s	Watts	cfm	L/s	Watts	cfm	L/s	Watts
.00	0	2450	1155	1170	2355	1110	1005	2145	1015	840	1845	870	705
.05	10	2430	1150	1165	2340	1105	995	2130	1005	835	1840	870	695
.10	25	2380	1120	1145	2315	1090	985	2105	995	825	1830	865	690
.15	35	2350	1110	1135	2260	1065	965	2085	985	815	1815	855	680
.20	50	2300	1085	1115	2235	1055	955	2060	975	805	1805	850	675
.25	60	2270	1070	1105	2205	1040	945	2015	950	785	1780	840	665
.30	75	2245	1060	1100	2150	1015	925	1995	940	775	1770	835	655
.40	100	2135	1010	1060	2070	975	895	1925	910	750	1730	815	640
.50	125	2055	970	1035	1990	940	870	1855	875	725	1695	800	625
.60	150	1975	930	1010	1910	900	845	1785	845	705	1650	775	605
.70	175	1870	880	980	1830	865	820	1695	800	680	1575	745	585
.80	200	1760	830	950	1720	815	795	1605	755	655	1505	710	570
.90	225	1625	765	915	1560	735	755	1515	715	640	1435	675	555

NOTE - All air data is measured external to unit with 1 in. (25 mm) cleanable filter (not furnished - field provided) in place. Also see Filter Air Resistance table.

BLOWER DATA Cont.

G60DF-60D-135 with 3/4 hp PERFORMANCE													
External Static Pressure		Air Volume / Watts at Different Blower Speeds											
		High			Medium-High			Medium-Low			Low		
in. w.g.	Pa	cfm	L/s	Watts	cfm	L/s	Watts	cfm	L/s	Watts	cfm	L/s	Watts
0.00	0	2845	1345	1143	2692	1270	961	2451	1155	818	2054	970	686
0.05	12	2774	1310	1128	2628	1240	948	2354	1110	809	2022	955	680
0.10	25	2702	1275	1112	2564	1210	935	2256	1065	799	1989	940	674
0.15	37	2629	1240	1095	2494	1175	918	2203	1040	784	1933	910	666
0.20	50	2556	1205	1077	2424	1145	901	2150	1015	769	1877	885	657
0.25	62	2471	1165	1061	2309	1090	890	2089	985	759	1835	865	649
0.30	75	2385	1125	1045	2194	1035	878	2028	955	749	1792	845	640
0.40	100	2184	1030	1022	2066	975	851	1900	895	727	1697	800	626
0.50	125	2019	955	990	1917	905	830	1779	840	707	1584	750	602
0.60	150	1865	880	957	1760	830	796	1630	770	676	1491	705	583
0.70	175	1697	800	927	1592	750	768	1475	695	656	1364	645	557
0.80	200	1513	715	897	1485	700	740	1378	650	627	1266	600	538
0.90	225	1385	655	863	1305	615	712	1206	570	598	1120	530	516

NOTE - All air data is measured external to unit with 1 in. (25 mm) cleanable filter (not furnished - field provided) in place. Also see Filter Air Resistance table.

G60DF-60C-110 with 1 hp PERFORMANCE													
External Static Pressure		Air Volume / Watts at Different Blower Speeds											
		High			Medium-High			Medium-Low			Low		
in. w.g.	Pa	cfm	L/s	Watts	cfm	L/s	Watts	cfm	L/s	Watts	cfm	L/s	Watts
.00	0	2475	1170	1276	2280	1075	987	1995	940	845	1690	795	698
.10	25	2390	1125	1248	2235	1055	955	1990	940	829	1675	790	690
.20	50	2330	1100	1223	2180	1030	945	1975	930	809	1665	785	675
.30	75	2245	1060	1192	2125	1000	911	1940	915	786	1660	785	657
.40	100	2175	1025	1187	2050	965	880	1895	895	757	1650	780	636
.50	125	2085	985	1145	1970	930	849	1835	870	734	1625	765	619
.60	150	2020	955	1129	1880	885	815	1750	825	695	1580	745	599
.70	175	1920	905	1094	1775	835	785	1660	785	669	1525	720	579
.80	200	1785	840	1052	1685	795	762	1585	745	645	1440	680	556
.90	225	1670	790	1020	1600	755	741	1520	715	633	1370	645	538

NOTE - All air data is measured external to unit with 1 in. (25 mm) cleanable filter (not furnished - field provided) in place. Also see Filter Air Resistance table.

BLOWER DATA Cont.

G60DF-60D-135 with 1 hp PERFORMANCE													
External Static Pressure		Air Volume / Watts at Different Blower Speeds											
		High			Medium-High			Medium-Low			Low		
in. w.g.	Pa	cfm	L/s	Watts	cfm	L/s	Watts	cfm	L/s	Watts	cfm	L/s	Watts
.00	0	2660	1255	1379	2325	1095	1059	1960	925	864	1655	780	684
.10	25	2560	1210	1353	2310	1090	1030	1945	915	840	1640	775	667
.20	50	2490	1175	1325	2280	1075	1000	1940	915	824	1630	770	661
.30	75	2415	1140	1293	2225	1050	972	1930	910	801	1625	765	649
.40	100	2345	1105	1264	2170	1025	941	1910	900	779	1620	760	638
.50	125	2265	1070	1235	2115	1000	918	1870	880	754	1615	760	624
.60	150	2165	1020	1199	2020	955	880	1830	865	733	1585	745	604
.70	175	2050	965	1160	1940	915	854	1755	830	705	1570	740	604
.80	200	1955	920	1112	1865	880	828	1680	790	683	1515	715	584
.90	225	1865	880	1096	1760	830	797	1605	755	656	1465	690	567

NOTE - All air data is measured external to unit with 1 in. (25 mm) cleanable filter (not furnished - field provided) in place. Also see Filter Air Resistance table.

1 FILTER AIR RESISTANCE							
cfm	L/s	in. w.g.	Pa	cfm	L/s	in. w.g.	Pa
0	0	0.00	0	1400	660	0.15	35
200	95	0.01	0	1600	755	0.19	45
400	190	0.03	5	1800	850	0.23	55
600	285	0.04	10	2000	945	0.27	65
800	380	0.06	15	2200	1040	0.33	80
1000	470	0.09	20	2400	1130	0.38	95
1200	565	0.12	30	2600	1225	0.44	110

1 Data is for 1 inch (25 mm) cleanable filter (field provided).

HIGH ALTITUDE / MANIFOLD PRESSURE INFORMATION											
Model Input Size	Gas	Altitude						Manifold Pressure at all altitudes			
		0 - 4500 ft. (0 - 1372 m)		4,501 - 7500 ft. (1373 - 2286 m)		7501-10,000 ft. (2286 - 3048 m)		Low Fire		High Fire	
		Required Conversion Kit	Pressure Switch	Required Conversion Kit	1Pressure Switch	Required Conversion Kit	1Pressure Switch	in. w.g.	kPa	in. w.g.	kPa
045/070-1 to -6	Nat.	no change	no change	no change	N/A	59M16	18M64	1.7	0.42	3.5	0.87
	LPG	59M13	59M13	59M13	N/A	59M14	18M64	4.9	1.22	10.0	2.5
045/070-7 and later	Nat.	no change	no change	no change	N/A	59M17	18M64	1.7	0.42	3.5	0.87
	LPG	59M13	59M13	59M13	N/A	59M14	18M64	4.9	1.22	10.0	2.5
090-1 to -6	Nat.	no change	no change	no change	18M61	59M16	18M64	1.7	0.42	3.5	0.87
	LPG	59M13	59M13	59M13	18M61	59M14	18M64	4.9	1.22	10.0	2.5
090-7 and later	Nat.	no change	no change	no change	18M61	59M17	18M64	1.7	0.42	3.5	0.87
	LPG	59M13	59M13	59M13	18M61	59M14	18M64	4.9	1.22	10.0	2.5
110/135-1 to -6	Nat.	no change	no change	no change	18M63	59M16	18M61	1.7	0.42	3.5	0.87
	LPG	59M13	59M13	59M13	18M63	59M14	18M61	4.9	1.22	10.0	2.5
110/135-7 and later	Nat.	no change	no change	no change	18M63	59M17	18M61	1.7	0.42	3.5	0.87
	LPG	59M13	59M13	59M13	18M63	59M14	18M61	4.9	1.22	10.0	2.5

Pressure switch is factory set. No adjustment necessary. All models use the factory installed pressure switch from 0-4500 feet (0-1372 m).

1 - Conversion requires 2 pressure switches

PARTS ARRANGEMENT

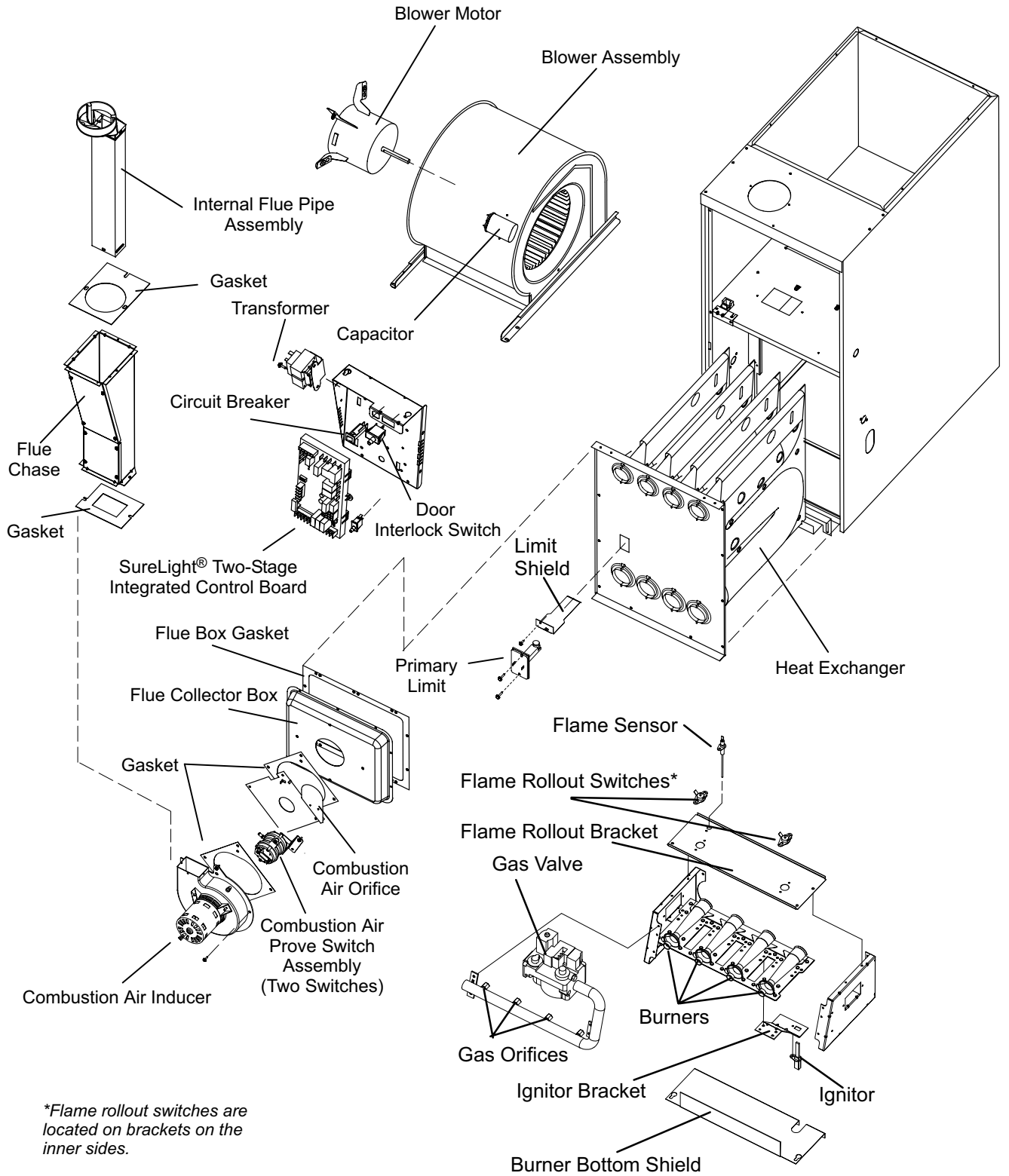

*Flame rollout switches are located on brackets on the inner sides.

NOTE - G60DF-1, -2 and -3 model units are equipped with a fully covered burner box.

FIGURE 1

I-UNIT COMPONENTS

Unit components are shown in figure 1. The gas valve, combustion air inducer and burners can be accessed by removing the burner access panel. Electrical components are in the control box (figure 2) found in the blower section.

ELECTROSTATIC DISCHARGE (ESD) Precautions and Procedures

⚠ CAUTION

Electrostatic discharge can affect electronic components. Take precautions during furnace installation and service to protect the furnace's electronic controls. Precautions will help to avoid control exposure to electrostatic discharge by putting the furnace, the control and the technician at the same electrostatic potential. Neutralize electrostatic charge by touching hand and all tools on an unpainted unit surface, such as the gas valve or blower deck, before performing any service procedure.

1. Control Transformer (T1)

A transformer located in the control box provides power to the low voltage section of the unit. Transformers on all models are rated 40VA with a 120V primary and a 24V secondary.

2. Door Interlock Switch (S51)

A door interlock switch rated 14A at 125VAC is wired in series with line voltage. When the blower door is removed the unit will shut down.

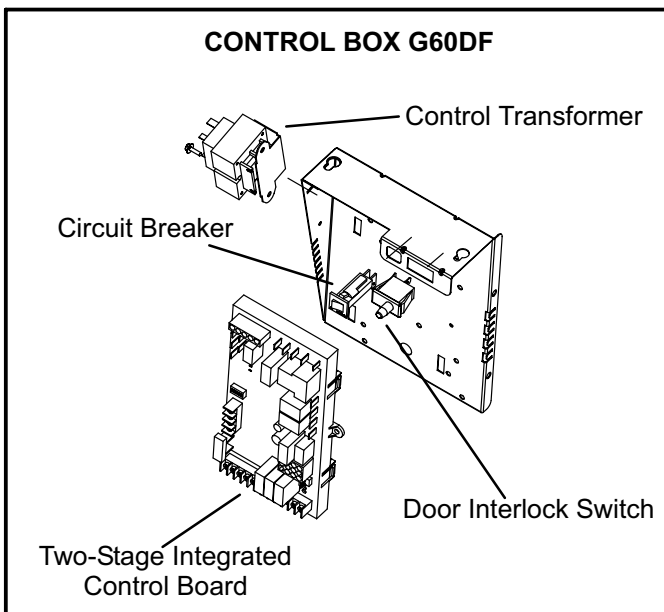

FIGURE 2

3. Circuit Breaker (CB8)

A 24V circuit breaker is also located in the control box. The switch provides overcurrent protection to the transformer (T1). The breaker is rated 3A at 32V. If the current exceeds this limit the breaker will trip and all unit operation will shutdown. The breaker can be manually reset by pressing the button on the face. See figure 3.

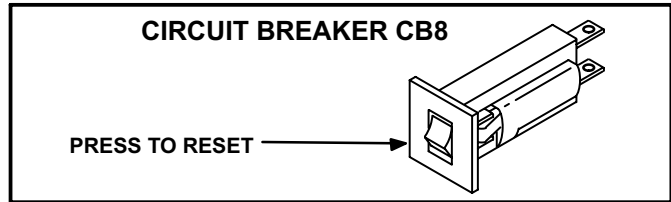

FIGURE 3

⚠ WARNING

Shock hazard.

Disconnect power before servicing. Integrated Control Board is not field repairable. If control is inoperable, simply replace entire control.

Can cause injury or death. Unsafe operation will result if repair is attempted.

4. Integrated Control Board(A92) SureLight® Board 18M34

All G60DF units are equipped with the Lennox two-stage integrated SureLight control board. The system consists of a ignition control board (figure 4 with control terminal designations in tables 3, 4 and 5) and ignitor (figure 8). The board and ignitor work in combination to ensure furnace ignition and ignitor durability. The board controls all major furnace operations. The board features two LED lights, DS1 and DS2 for troubleshooting. The board also has two accessory terminals rated at (1) one amp each. See table 6 for troubleshooting diagnostic codes.

Electronic Ignition

At the beginning of each heat cycle, SureLight control monitors the first stage and second stage combustion air inducer prove switch. The control will not begin the heating cycle if the first stage prove switch is closed (by-passed). Likewise the control will not begin the second stage heating cycle if the second stage prove switch is closed and will allow first stage heat only. However if the second stage prove switch closes during the first stage pre-purge, the control will still respond to second stage heat. Once the first stage prove switch is determined to be open, the combustion air inducer is energized on low (first stage) heat speed. When the differential in the prove switch is great enough, the prove switch closes and a 15-second pre-purge begins. If the switch is not proven within 2-1/2 minutes, the control goes into Watchguard-Pressure Switch mode for a 5-minute re-set period.

After the 15-second pre-purge period, the SureLight ignitor warms up for 20 seconds after which the gas valve opens for a 4-second trial for ignition. The ignitor energizes during the trial until flame is sensed. If ignition is not proved during the 4-second period, the control will try four more times with an inter purge and warm-up time between trials of 35 seconds. After a total of five trials for ignition (including the initial trial), the control goes into Watchguard-Flame Failure mode. After a 60-minute reset period, the control will begin the ignition sequence again.

The SureLight control board has an added feature that prolongs the life of the ignitor. After a successful ignition, the SureLight control utilizes less power to energize the ignitor on successive calls for heat. The control continues to ramp down the voltage to the ignitor until it finds the lowest amount of power that will provide a successful ignition. This amount of power is used for 255 cycles. On the 256th call for heat, the control will again ramp down until the lowest power is determined and the cycle begins again.

Two Stage Operation / Thermostat Selection Jumper

The control can be utilized in two modes: SINGLE-STAGE thermostat or TWO-STAGE thermostat. The thermostat selection jumper E20, located just below dip switches 1 through 4 (figure 4), must be positioned for the particular application. The jumper is factory set on "TWO" for use with a two-stage thermostat with two stage heat. Re-position jumper to "SINGLE" for use with a single stage thermostat with two stage heat.

While in the single-stage thermostat mode (*single* jumper setting), the burners will always fire on first-stage heat. The combustion air inducer will operate on low speed and indoor blower will operate on low heat speed. After a field selectable 10 or 15 minute delay (dip switch 3), the unit will switch to second stage heat. While in the two-stage thermostat mode (*two* jumper setting) the burners will fire on first-stage heat. The combustion air inducer will operate on low speed and indoor blower will operate on low heat speed. The unit will switch to second-stage heat on call from the indoor thermostat. If there is a simultaneous call for W1 and W2 (first and second stage heat) the unit will fire on first stage heat and will switch to second stage heat after 30 seconds of operation. See Sequence of Operation flow charts in the back of this manual for more detail.

Dip Switch Settings

Dip Switches 1 and 2 - Heating Fan off Delay - The fan on time of 45 seconds is not adjustable. Fan off time (time that the blower operates after the heat demand has been satisfied) can be adjusted by flipping the dip switches 1 and 2 located on the SureLight integrated control. The unit is shipped with a factory fan off setting of 90 seconds. Fan off time will affect comfort and is adjustable to satisfy individual applications.

For customized comfort, monitor the supply air temperature once the heat demand is satisfied. Note the supply air temperature at the instant the blower is de-energized. Adjust the fan-off delay to achieve a supply air temperature between 90° - 110° at the instant the blower is de-energized. (Longer delay times allow for lower air temperature, shorter delay times allow for higher air temperature). See table 1 for dip switch settings.

TABLE 1
Heating Fan Off Delay

Delay (Seconds)	Switch 1	Switch 2
60	Off	Off
90	Off	On
120	On	Off
180	On	On

Switch 3 - Second Stage Delay (Used with Single-Stage Thermostat Only) -- This switch is used to determine the second stage on delay when a single-stage thermostat is being used. The switch is factory-set in the ON position, which provides a 10-minute delay before second-stage heat is initiated. If the switch is toggled to the OFF position, it will provide a 15-minute delay before second-stage heat is initiated. This switch is only activated when the thermostat selector jumper is positioned for SINGLE-stage thermostat use.

Switch 4 - Cooling Fan off Delay - The fan on delay time of 2 seconds is not adjustable. Fan off time (time that the blower operates after the cool demand has been satisfied) can be adjusted by flipping dip switch 4. The unit is shipped with a factory fan off setting of 45 seconds. Fan off time will affect comfort and is adjustable to satisfy individual applications. See table 2 for cool fan off time settings.

TABLE 2
Cooling Fan Off Delay

Delay (Seconds)	Switch 4
2	Off
45	On

Diagnostic LED's (DS1 and DS2)

Two diagnostic LED'S are located on the two-stage integrated control board. See figure 4. These light flashes correspond with the codes detailed in table 6.

Factory Installed Jumper Y1 to Y2

A factory-installed jumper from Y1 to Y2 terminals on the integrated control board terminal strip must be clipped for two-stage cooling.

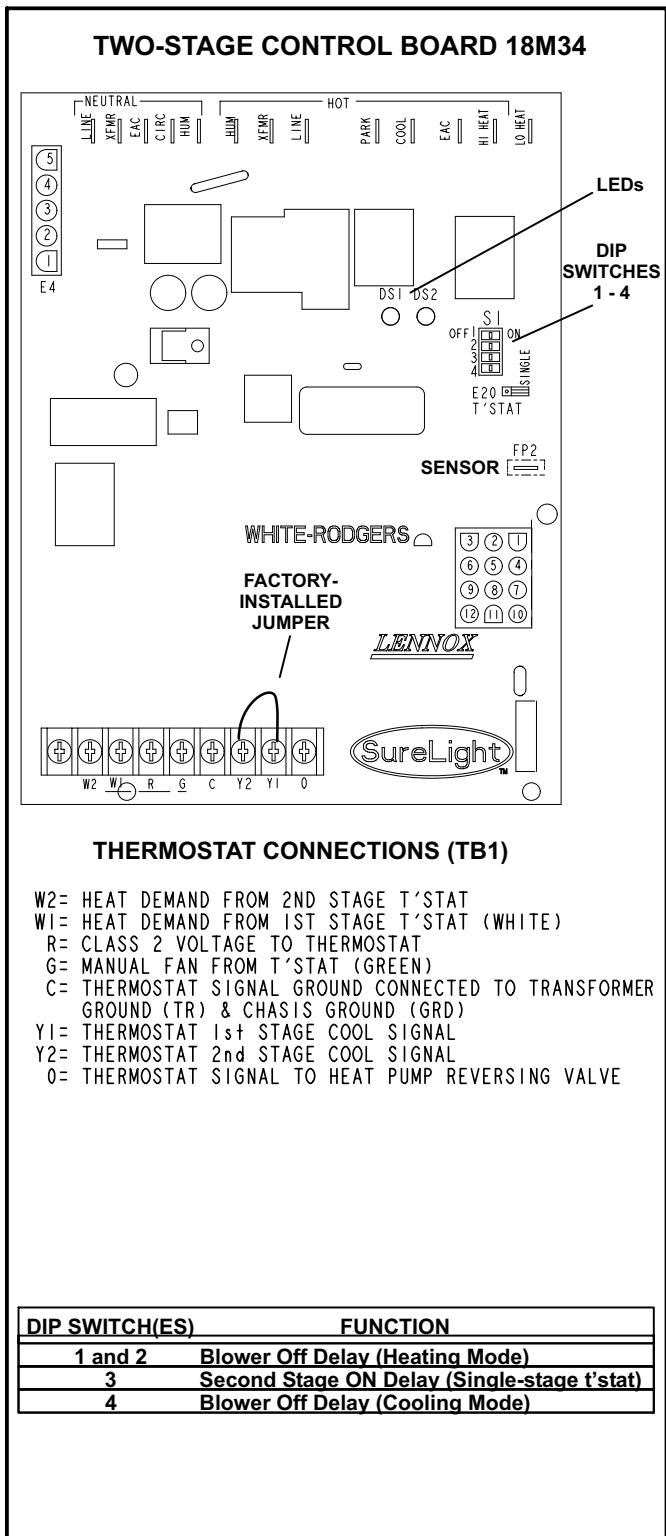

FIGURE 4

TABLE 3

Integrated Control Board Terminals	
120VAC Neutral	
LINE	Line
XFMR	Transformer
EAC	Electronic Air Cleaner
CIRC	Indoor Blower
HUM	Humidifier
120VAC Line	
HUM	Humidifier
XMFR	Transformer
LINE	Line
PARK	For Unused Leads
COOL	Cooling Speed
EAC	Electronic Air Cleaner
HI HEAT	High Heat Speed
LO HEAT	Low Heat, Low Cool and Continuous Fan Speed

TABLE 4

Integrated Control Board 5 Pin Terminal	
PIN #	Function
1	Ignitor
2	Combustion Air Inducer High Speed
3	Combustion Air Inducer Low Speed
4	Combustion Air Inducer Neutral
5	Ignitor Neutral

TABLE 5

Integrated Control Board 12Pin Terminal	
PIN #	Function
1	Gas Valve 2nd Stage (High Fire)
2	Second Stage Prove Switch
3	Not Used
4	Ground
5	24V Hot
6	Primary Limit In
7	Gas Valve 1st stage (Low Fire)
8	Gas Valve Common
9	24V Neutral
10	Ground
11	Primary Limit Out
12	1st Stage Prove Switch

TABLE 6

DIAGNOSTIC CODES

Diagnostic LEDs are labeled DS1 and DS2. See figure 4 for location of diagnostic LEDs.

DS1	DS2	DESCRIPTION
SIMULTANEOUS SLOW FLASH	SIMULTANEOUS SLOW FLASH	Power on - Normal operation. Also signaled during cooling and continuous fan.
SIMULTANEOUS FAST FLASH	SIMULTANEOUS FAST FLASH	Normal operation - signaled when heating demand initiated at thermostat.
SLOW FLASH	ON	Primary, secondary or rollout limit switch open. Limits must close within 3 minutes or unit goes into 1 hour Watchguard.
OFF	SLOW FLASH	Low prove switch open; OR: Blocked inlet/exhaust vent; OR: Low prove switch closed prior to activation of combustion air inducer.
OFF	FAST FLASH	High prove switch open; OR: Blocked inlet/exhaust vent; OR: High prove switch closed prior to activation of combustion air inducer.
ALTERNATING SLOW FLASH	ALTERNATING SLOW FLASH	Watchguard -- burners failed to ignite; OR limit open more than 3 minutes; OR lost flame sense 5 times in one heating cycle; OR pressure switch opened 5 times in one heating cycle.
SLOW FLASH	OFF	Flame sensed without gas valve energized.
ON ON OFF	ON OFF ON	Circuit board failure or control wired incorrectly. Check 24 and 115 volts to board.
FAST FLASH	SLOW FLASH	Main power polarity reversed. Switch line and neutral.
SLOW FLASH	FAST FLASH	Low flame signal. Measures below 0.23 microAmps. Replace flame sense rod.
ALTERNATING FAST FLASH	ALTERNATING FAST FLASH	The following conditions are sensed during the ignitor warm-up period only: 1) Improper main ground; 2) Broken ignitor; OR: Open ignitor circuit; 3) Line voltage below 75 volts. (If voltage lower than 75 volts prior to ignitor warm-up, control will signal waiting on call from thermostat, and will not respond.

NOTE - Slow flash rate equals 1 Hz (one flash per second). Fast flash rate equals 3 Hz (three flashes per second). Low flame sense current = 0.17-0.22 microAmps.

⚠ WARNING

Shock hazard.

Disconnect power before servicing. Integrated Control Board is not field repairable. If control is inoperable, simply replace entire control.

Can cause injury or death. Unsafe operation will result if repair is attempted.

5. Integrated Control Board(A92) SureLight Board 100869

G60DF units are equipped with the Lennox two-stage integrated SureLight control board. The system consists of a ignition / blower control board (figures 5 and 6) with control pin designations in tables 8 and 9 and an ignitor (figure 9). The board and ignitor work in combination to ensure furnace ignition and ignitor durability. The SureLight integrated board controls all major furnace operations. The board features a red LED light, for furnace status and troubleshooting. The LED flashes in “X” + “Y” codes. For example using table 10 under “PRESSURE SWITCH CODES”, if the red LED flashes 2 times, then off for 2 seconds then flashes 3 times, the low pressure switch is failed open. The board also has two 120 volt accessory terminals rated at (1) one amp each and one 24 volt accessory terminal rated at 0.5.

Electronic Ignition

At the beginning of the heat cycle the SureLight control monitors the first stage and second stage combustion air inducer prove switch. The control will not begin the heating cycle if the first stage prove switch is closed (by-passed). Likewise the control will not begin the second stage heating cycle if the second stage prove switch is closed, and will remain in first stage heat. However, if the second stage prove switch closes during the first stage heat pre-purge, the control will allow second stage heat. Once the first stage prove switch is determined to be open, the combustion air inducer is energized on low (first stage) heat speed. When the differential in the prove switch is great enough, the prove switch closes and a 15-second pre-purge begins. If the switch is not proven within 2-1/2 minutes, the control goes into Watchguard-Pressure Switch mode for a 5-minute reset period.

After the 15-second pre-purge period, the SureLight ignitor warms up for 20 seconds after which the gas valve opens for a 4-second trial for ignition. The ignitor energizes during the trial until flame is sensed. If ignition is not proved during the 4-second period, the control will try four more times with an inter purge and warm-up time between trials of 35 seconds. After a total of five trials for ignition (including the initial trial), the control goes into Watchguard-Flame Failure mode. After a 60-minute reset period, the control will begin the ignition sequence again.

NOTE - Board 100869 DOES NOT ramp down voltage to the ignitor. A regulated 95 volts is provided to the igniter at ignition.

Two Stage Operation / Thermostat Selection Jumper

The control can be utilized in two modes: SINGLE-STAGE thermostat or TWO-STAGE thermostat. The thermostat selection is made using a dip switch (figure NO TAG) and must be positioned for the particular application. The dip switch is factory set on “TWO” for use with a two-stage thermostat with two stage heat. Re-position dip switch to “SINGLE” for use with a single stage thermostat with two stage heat.

While in the single-stage thermostat mode (*single* dip switch setting), the burners will always fire on first-stage heat. The combustion air inducer will operate on low speed and indoor blower will operate on low heat speed. After a 10 minute recognition period, the unit will switch to second stage heat. While in the two-stage thermostat mode (*two* dip switch setting) the burners will fire on first-stage heat. The combustion air inducer will operate on low speed and indoor blower will operate on low heat speed. The unit will switch to second-stage heat on call from the indoor thermostat. If there is a simultaneous call for first and second stage heat, the unit will fire an first stage heat and switch to second stage heat after 30 seconds of operation. See Sequence of Operation flow charts in the back of this manual for more detail.

DIP Switch Settings

Switch 1 -- Thermostat Selection -- This unit may be used with either a single-stage or two-stage thermostat. The thermostat selection is made using a DIP switch which must be properly positioned for the particular application. The DIP switch is factory-positioned for use with a two-stage thermostat. If a single-stage thermostat is to be used, the DIP switch must be repositioned.

- a - Select "OFF" for two-stage heating operation controlled by a two-stage heating thermostat (factory setting);
- b - Select "ON" for two-stage heating operation controlled by a single-stage heating thermostat. This setting provides a timed delay before second-stage heat is initiated.

Switch 2 -- Second Stage Delay (Used with Single-Stage Thermostat Only) -- This switch is used to determine the second stage on delay when a single-stage thermostat is being used. The switch is factory-set in the OFF position, which provides a 10-minute delay before second-stage heat is initiated. If the switch is toggled to the ON position, it will provide a 15-minute delay before second-stage heat is initiated. This switch is only activated when the thermostat selector jumper is positioned for SINGLE-stage thermostat use.

Switches 3 and 4 -- Heating Blower-Off Delay -- The heating blower-on delay of 45 seconds is not adjustable. The heating blower-off delay (time that the blower operates after the heating demand has been satisfied) can be adjusted by moving switches 3 and 4 on the integrated control board. The unit is shipped from the factory with a heating blower-off delay of 90 seconds. The heating blower off delay affects comfort and is adjustable to satisfy individual applications. Adjust the blower off delay to achieve a supply

air temperature between 90° and 110°F at the exact moment that the blower is de-energized. Longer off delay settings provide lower supply air temperatures; shorter settings provide higher supply air temperatures. Table 7 provides the blower off timings that will result from different switch settings.

TABLE 7
Heating Blower-Off Delay Switch Settings

Blower Off Delay (Seconds)	Switch 3	Switch 4
60	Off	On
90	Off	Off
120	On	Off
180	On	On

Switch 5 -- Cooling Blower-Off Delay -- The cooling blower-off delay (time that the blower operates after the cooling demand has been satisfied) can be adjusted by moving switch 5 on the integrated control board. The switch is factory-set in the OFF position, which provides a cooling blower-off delay of 45 seconds. If the switch is toggled to the ON position, it will provide a 2-second cooling blower-off delay

On-Board Jumper W951

On-board jumper W951, which connects terminals R and O on the integrated control board, must be cut when the furnace is installed in applications which include a heat pump unit and a thermostat which features dual fuel use. If the jumper is left intact, terminal "O" will remain energized eliminating the HEAT MODE in the heat pump.

On-Board Jumper W915

On-board jumper W915, which connects terminals Y1 and Y2 on the integrated control board, must be cut if two-stage cooling will be used. If the jumper is not cut the outdoor unit will operate in first-stage cooling only.

CONTROL BOARD 100869

1/4" QUICK CONNECT TERMINALS

HUM = 120 VAC OUTPUT TO HUMIDIFIER
 EAC = 120 VAC OUTPUT TO ELECTRONIC AIR CLEANER
 XMFR = 120 VAC OUTPUT TO TRANSFORMER
 LI = 120 VAC INPUT TO CONTROL
 SENSE = 120 VAC OUTPUT TO FLAME SENSER

NEUTRALS= 120 VAC NEUTRAL

PARK = DEAD TERMINAL FOR UNUSED BLOWER LEAD
 HEAT LOW = 120 VAC OUTPUT TO CIRC BLWR -- LOW HT SPEED
 HEAT HIGH/ COOL LOW = 120 VAC OUTPUT TO CIRC BLWR --
 HIGH HEAT AND LOW COOL SPEED
 COOL HIGH = 120 VAC OUTPUT TO CIRC BLWR -- HIGH COOL SPEED

THERMOSTAT CONNECTIONS (TB1)

W1= HEAT DEMAND FROM 1ST STAGE T'STAT
 W2= HEAT DEMAND FROM 2ND STAGE T'STAT
 G= MANUAL FAN FROM T'STAT
 Y2= THERMOSTAT 2nd STAGE COOL SIGNAL
 Y1= THERMOSTAT 1st STAGE COOL SIGNAL
 C= THERMOSTAT SIGNAL GROUND CONNECTED TO TRANSFORMER
 GROUND (TR) & CHASSIS GROUND (GRD)
 R= CLASS 2 VOLTAGE TO THERMOSTAT
 1= ERROR CODE RECALL
 H= 24V HUMIDIFIER OUTPUT
 L= LENNOX SYSTEM OPERATION MONITOR
 0= THERMOSTAT SIGNAL TO HEAT PUMP REVERSING VALVE

DIP SWITCH FUNCTIONS

DIP SWITCH(ES)	FUNCTION
1 -- 2 Stage T'stat	Selects t/stat type (single or two-stage)
2 -- 2nd Stage Delay	Second stage ON delay (single-stage t'stat)
3 & 4 -- Heat Off Delay	Heating fan OFF delay
5 -- Cool Off Delay	Cooling fan OFF delay

FIGURE 5

TABLE 8

PIN #	Function
1	Ignitor
2	Combustion Air Inducer High Speed
3	Combustion Air Inducer Low Speed
4	Combustion Air Inducer Neutral
5	Ignitor Neutral

TABLE 9

PIN #	Function
1	Gas Valve High Fire
2	Second Stage Prove Switch
3	Rollout In
4	Ground
5	24V Hot
6	Primary Limit In
7	Gas Valve Low Stage
8	Gas Valve Common
9	24V Neutral
10	Ground
11	Rollout Switch Out
12	1st Stage Prove Switch

CONTROL BOARD 100869

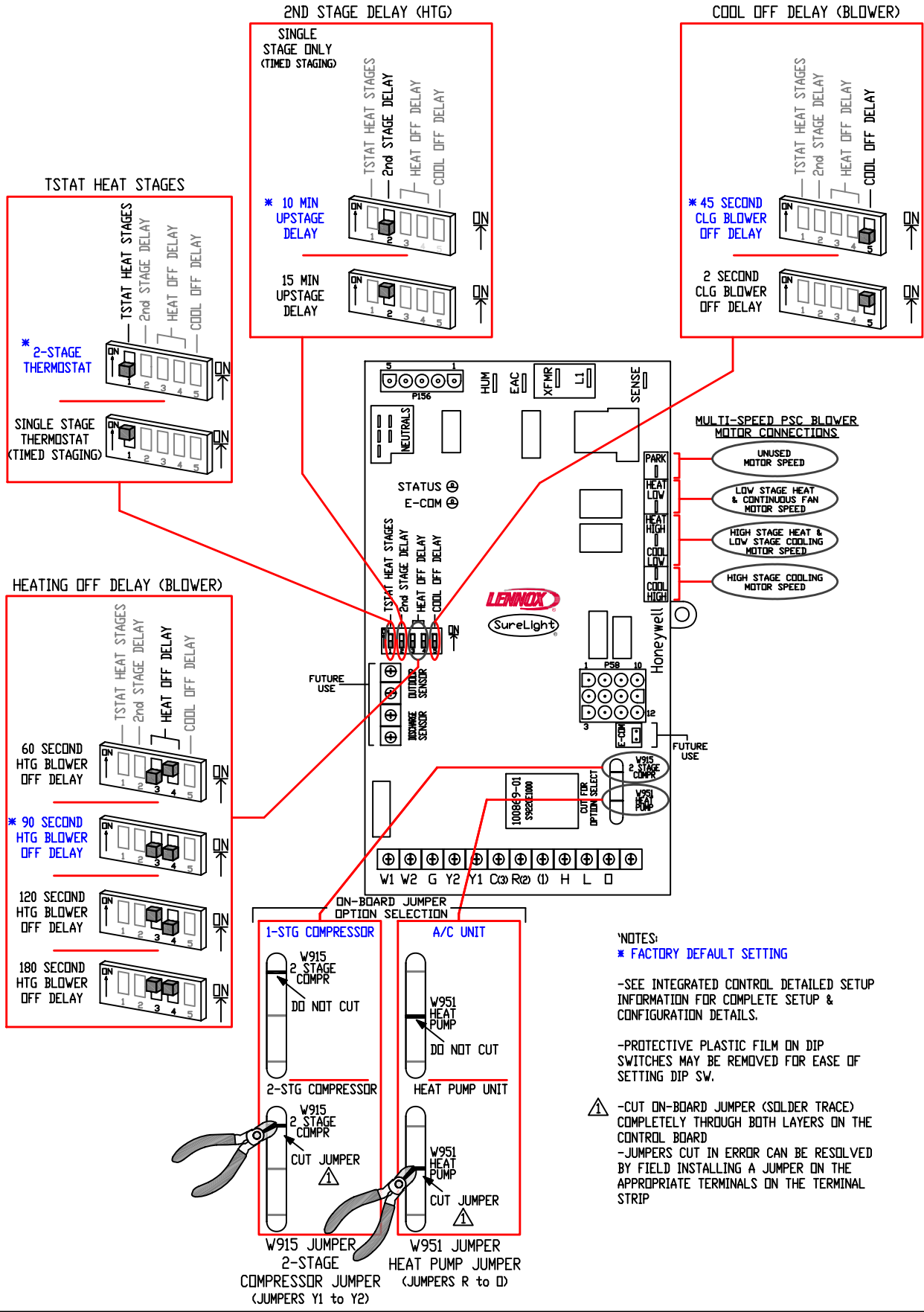

FIGURE 6

TABLE 10

FLASH CODE (X + Y)	STATUS / ERROR DESCRIPTION
FLASH CODE DESCRIPTIONS	
Pulse	A 1/4 second flash followed by four seconds of off time.
Heartbeat	Constant 1/2 second bright and 1/2 second dim cycles.
X + Y	LED flashes X times at 2Hz, remains off for two seconds, flashes Y times at 2Hz, remains off for four seconds, then repeats.
Pulse	Power on - Standby.
Heartbeat	Normal operation - signaled when heating demand initiated at thermostat.
FLAME CODES	
1 + 2	Low flame current -- run mode.
1 + 3	Flame sensed out of sequence -- flame still present.
PRESSURE SWITCH CODES	
2 + 3	Low pressure switch failed open.
2 + 4	Low pressure switch failed closed.
2 + 5	High pressure switch failed open.
2 + 6	High pressure switch failed closed.
2 + 7	Low pressure switch opened during ignition trial or heating demand.
LIMIT CODE	
3 + 1	Limit switch open.
WATCHGUARD CODES	
4 + 1	Watchguard -- Exceeded maximum number of retries.
4 + 2	Watchguard -- Exceeded maximum number of retries or last retry was due to pressure switch opening.
4 + 3	Watchguard -- Exceeded maximum number of retries or last retry was due to flame failure.
4 + 5	Watchguard -- Limit remained open longer than three minutes.
4 + 6	Watchguard -- Flame sensed out of sequence; flame signal gone.
4 + 7	Ignitor circuit fault -- Failed ignitor or triggering circuitry.
4 + 8	Low line voltage.
HARD LOCKOUT CODES	
5 + 1	Hard lockout -- Rollout circuit open or previously opened.
5 + 2	Control failed self check, internal error (control will restart if error recovers).
5 + 3	No Earth ground (control will restart if error recovers).
5 + 4	Reversed line voltage polarity (control will restart if the error recovers).
5 + 6	Low secondary (24VAC) voltage.

Error Code Storage

The ignition control stores the last ten error codes in memory. The codes are retained in case of power loss.

Error Code Review

- 1 - Short R (2) to (1). Within 1/2 second, the STATUS LED will stay lit continuously to indicate that the short was sensed.
- 2 - Continue to hold the short between R (2) to (1). After 5 seconds, STATUS LED will go from being continuously lit to off. This indicates that error code review is pending.
- 3 - Remove R (2) to (1) short within ten seconds of STATUS LED turning off. This activates error code review.
- 4 - Last ten error codes will be flashed on the STATUS LED.

- 5 - After final error code is indicated, STATUS LED will flash to indicate normal operation.

Clearing Error Codes

- 1 - Short R (2) to (1). Within 1/2 second, the STATUS LED will stay lit continuously to indicate that the short was sensed.
- 2 - Continue to hold the short between R (2) to (1). After 5 seconds, STATUS LED will go from being continuously lit to off.
- 3 - Continue to hold the short between R (2) to (1) beyond ten seconds after STATUS LED has turned off. STATUS LED will turn on, indicating that error codes have been cleared.
- 4 - Remove R (2) to (1) short. STATUS LED will flash to indicate normal operation.

6. Blower Motors and Capacitors

All G60DFunits use direct drive blower motors. All motors are 120V permanent split capacitor motors to ensure maximum efficiency. Ratings for capacitors will be on motor nameplate. See SPECIFICATIONS section for motor specifications. Follow the steps in figure 7 for blower removal.

NOTE - Shafts on 1 HP motors have 2 flat sides and are matched with blower wheels with 2 set screws.

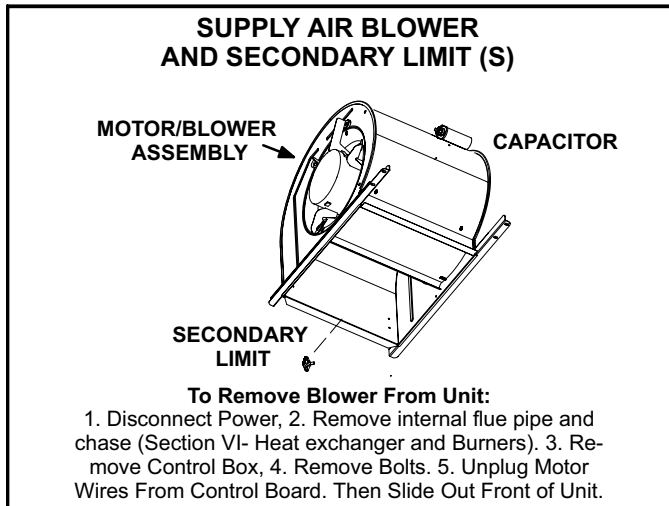

FIGURE 7

7. Ignitor

The SureLight ignitor is made of durable silicon nitride. Ignitor longevity is enhanced by controlling voltage to the ignitor. Board 18M34 finds the lowest ignitor temperature which will successfully light the burner, thus increasing the life of the ignitor. Due to this feature of the board, voltage cannot be measured so ignitor must be ohmed. Board 100869 provides a regulated 95 volts to the ignitor for consistent ignition and long ignitor life. Ohm value for ignitors with SureLight board 18M34 should be 10.9 to 19.7. Ohm value for ignitors with board 100869 should be 25 to 47. See figure 8 and 9 (make note of control board used) for ignitor location.

NOTE - The G60DF(X) furnace contains electronic components that are polarity sensitive. Make sure that the furnace is wired correctly and is properly grounded.

8. Flame Sensor

A flame sensor is located on the left side of the burner support. See figure 10 and 11 (make note of control board used). The sensor is mounted on the flame rollout plate and the tip protrudes into the flame envelope of the left-most burner. The sensor can be removed for service without removing any part of the burners. During operation, flame is sensed by current passed through the flame and sensing electrode. The SureLight control allows the gas valve to remain open as long as flame signal is sensed.

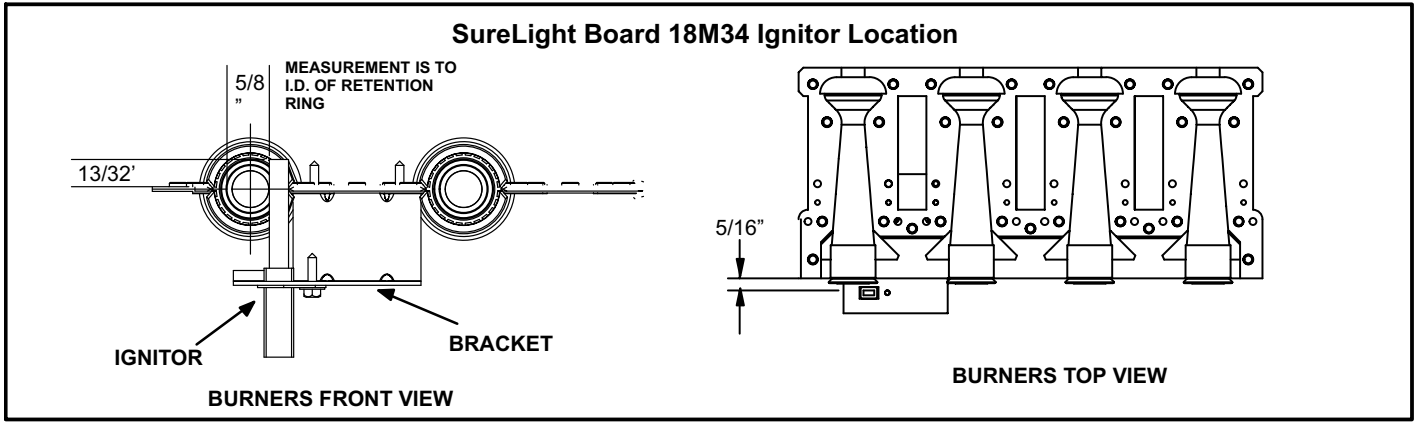

FIGURE 8

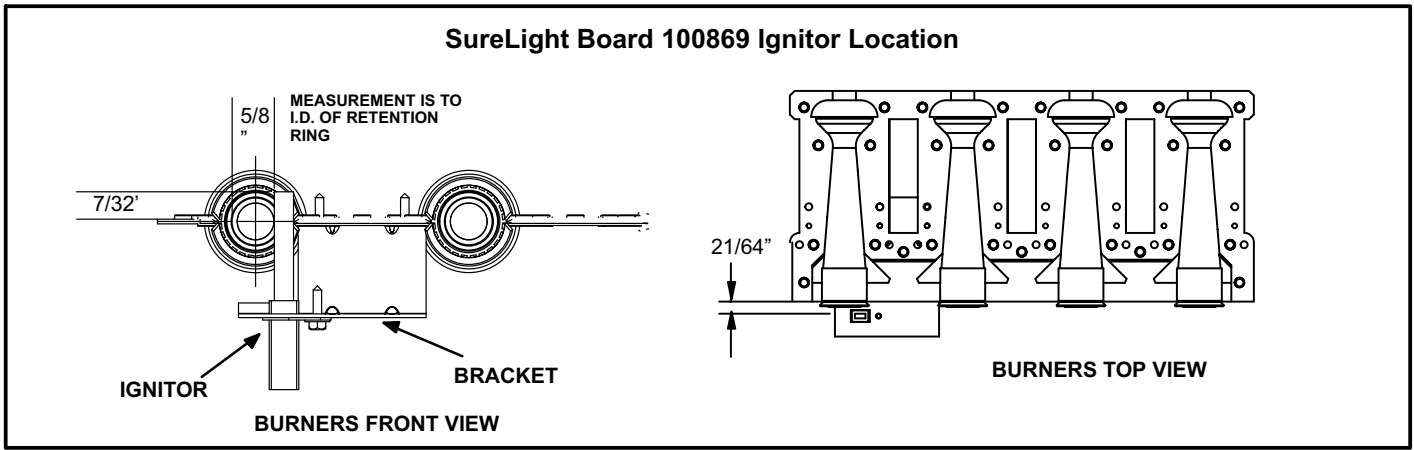
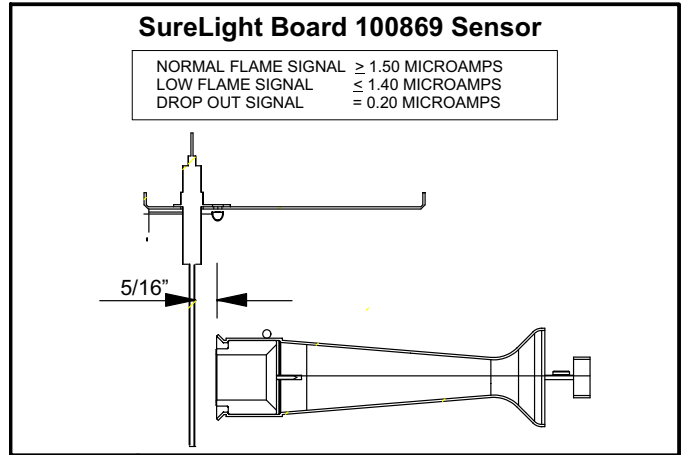
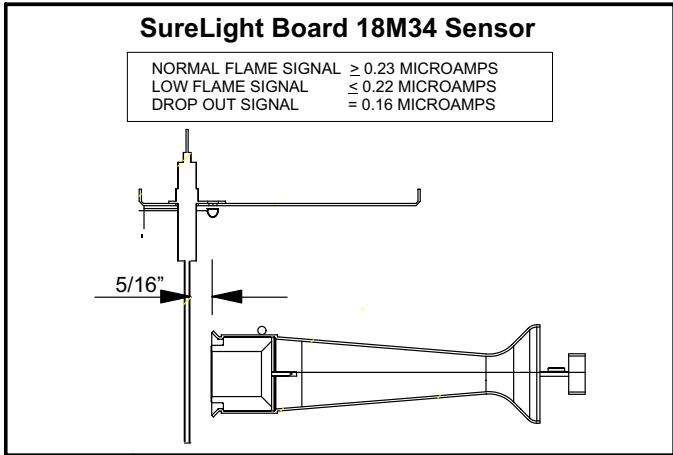

FIGURE 9



9. Combustion Air Inducer (B6)

All units use a two-stage combustion air inducer to move air through the burners and heat exchanger during heating operation. The blower uses a 120VAC motor. The motor operates during all heating operation and is controlled by furnace / blower control (A92). The inducer also operates for 15 seconds before burner ignition (pre-purge) and for 5 seconds after the gas valve closes (post-purge). The inducer operates on low speed during first-stage heat, then switches to high speed for second stage heat.

A proving switch connected to the combustion air inducer orifice plate is used to prove inducer operation. The combustion air inducer orifice will be different for each model. See table 11 for orifice sizes. The switch monitors air pressure in the inducer housing. During normal operation, the pressure in the housing is negative. If pressure becomes less negative (signifying an obstruction) the proving switch opens. When the prove switch opens, the furnace control (A92) immediately closes the gas valve to prevent burner operation.

TABLE 11

G60DF Unit	C.A.I. Orifice Size
-045-1, -2	1.250"
-070-1, -2	1.563"
-070-4 and later	1.500"
-090-1, -2	1.875"
-090-4 and later	1.750"
-110 all units	2.156"
-135-2, -3	2.600"

10. Flame Rollout Switches (S47)

In all G60DF-1, -2 and -3 units, flame rollout switch is a high temperature limit located on top of the burner box. Each furnace is equipped with two identical switches (-045 model will have one switch located in the center). One switch is located over the leftmost burner and the other switch is located over the rightmost burner. All G60DF-4 and later models have the two switches located on brackets inside the burner box. S47 is a N.C. SPST manual-reset limit. When S47 senses rollout, the circuit breaks and the ignition control immediately stops ignition and closes the gas valve.

If unit is running and flame rollout is detected, the gas valve will close and ignition control will be disabled. Rollout can be caused by a blocked heat exchanger, flue or lack of combustion air. The switch is factory set to trip (open) at 210°F and cannot be adjusted. The switch can be manually reset. To manually reset a tripped switch, push the reset button located on the control.

11. Primary Limit Control (S10)

The primary limit (S10) is located in the heating vestibule panel. When excess heat is sensed in the heat exchanger, the limit will open. If the limit is open, the furnace control energizes the supply air blower and closes the gas valve. The limit automatically resets when unit temperature returns to normal. The switch must reset within three minutes or the SureLight board will go into Watch guard for one hour. The switch is factory set and cannot be adjusted. The switch may have a different set point for each unit model number. Refer to Repair Parts Handbook for correct length and set point.

12. Secondary Limit Controls (S21)

The secondary limit (S21) is located in the blower compartment on the back side of the blower housing. See figure 7. When excess heat is sensed in the blower compartment, the limit will open. If the limit is open, the furnace control energizes the supply air blower and closes the gas valve. The limit automatically resets when unit temperature returns to normal. G60DF-1 through -4 units use a surface type limit that is factory set to open at 125°F. G60DF-5 and later units use an air stream limit factory set to open at 135°. The secondary limit cannot be adjusted.

13. Gas Valve

All units use a two-stage gas valve manufactured by Honeywell (figure 13). The valve is internally redundant to assure safety shut-off. If the gas valve must be replaced, the same type valve must be used.

24VAC terminals and gas control knob are located on the valve. All terminals on the gas valve are connected to wires from the electronic ignition control. 24V applied to the terminals energizes the valve.

Inlet and outlet pressure taps are located on the valve. A regulator adjustment screw is located on the valve.

LPG change over kits are available from Lennox. Kits include burner orifices and a gas valve regulator conversion kit.

14. Combustion Air Inducer Prove Switch (S18)

S18 is a dual combustion air proving switch (first and second stage) located on the combustion air inducer orifice bracket. The switch is connected to the combustion air inducer housing by means of a flexible silicone hose. It monitors negative air pressure in the combustion air inducer housing.

The switches are a single-pole single-throw proving switch electrically connected to the furnace control. The purpose of the switch is to prevent burner operation if the combustion air inducer is not operating or if the flue becomes obstructed.

On heat demand (first or second stage) the switch senses that the combustion air inducer is operating. It closes a circuit to the furnace control when pressure inside the combustion air inducer decreases to a certain set point.

Set points vary depending on unit size. See tables 12, 13 and 14. The pressure sensed by the switch is negative relative to atmospheric pressure. If the flue becomes obstructed during operation, the switch senses a loss of negative pressure (pressure becomes more equal with atmospheric pressure) and opens the circuit to the furnace control and gas valve. A bleed port on the switch allows relatively dry air in the vestibule to purge switch tubing, to prevent condensate build up.

The switch is factory set and is not field adjustable. It is a safety shut-down control in the furnace and must not be by-passed for any reason. If switch is closed or by-passed, the control will not initiate ignition at start up.

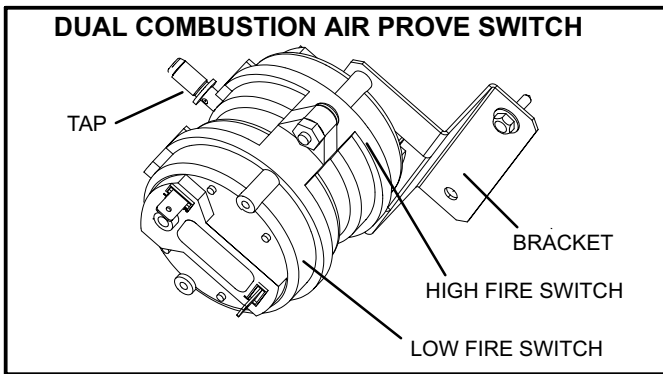

FIGURE 12

TABLE 12
0' to 4500'

G60DF Unit	Set Point High Heat	Set Point Low Heat
-045	0.40"	0.20"
-070	0.40"	0.20"
-090	0.45"	0.20"
-110	0.50"	0.20"
-135	0.50"	0.20"

TABLE 13*
4501' to 7500'

G60DF Unit	Set Point High Heat	Set Point Low Heat
-045	0.40"	0.20"
-070	0.40"	0.20"
-090	0.40"	0.20"
-110	0.45"	0.20"
-135	0.45"	0.20"

**Unit requires conversion kit at this altitude. See High Altitude table.*

TABLE 14*
7501' to 10,000'

G60DF Unit	Set Point High Heat	Set Point Low Heat
-045	0.35"	0.20"
-070	0.35"	0.20"
-090	0.35"	0.20"
-110	0.40"	0.20"
-135	0.40"	0.20"

**Unit requires conversion kit at this altitude. See High Altitude table.*

II-PLACEMENT AND INSTALLATION

Make sure unit is installed in accordance with installation instructions and applicable codes.

III-START-UP

A-Preliminary and Seasonal Checks

- 1 - Inspect electrical wiring, both field and factory installed for loose connections. Tighten as required.
- 2 - Check voltage at disconnect switch. Voltage must be within range listed on the nameplate. If not, consult the power company and have voltage condition corrected before starting unit.

B-Heating Start-Up

⚠ WARNING

Shock and burn hazard.

G60DF units are equipped with a hot surface ignition system. Do not attempt to light manually.

- 1 - **STOP!** Read the safety information at the beginning of this section.
- 2 - Set the thermostat to the lowest setting.
- 3 - Turn off all electrical power to the unit.
- 4 - This furnace is equipped with an ignition device which automatically lights the burners. Do **not** try to light the burners by hand.
- 5 - Remove the upper access panel.
- 6 - *Honeywell VR8205 Gas Valve* - Turn knob on gas valve clockwise ➡ to **OFF**. Do not force. See figure 13.
- 7 - Wait five minutes to clear out any gas. If you then smell gas, **STOP!** Immediately call your gas supplier from a neighbor's phone. Follow the gas supplier's instructions. If you do not smell gas go to next step.

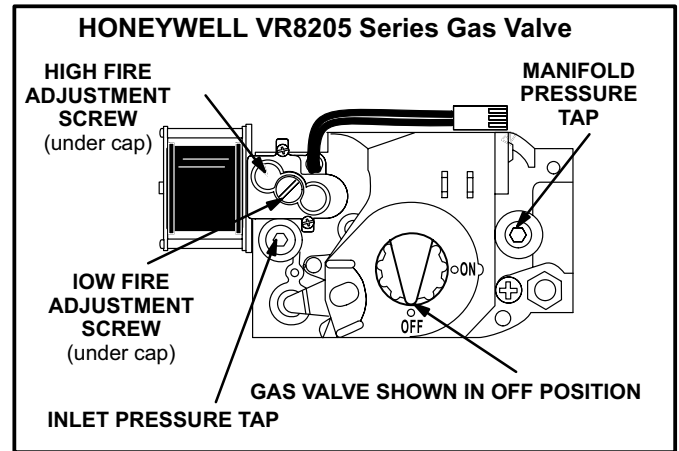

FIGURE 13

8 - *Honeywell VR8205 Gas Valve* - Turn knob on gas valve counterclockwise ↶ to **ON**. Do not force. See figure 13.

9 - Replace the upper access panel.

10- Turn on all electrical power to the unit.

11- Set the thermostat to desired setting.

NOTE - When unit is initially started, steps 1 through 11 may need to be repeated to purge air from gas line.

Turning Off Gas To Unit

- 1 - Set thermostat to lowest setting.
- 2 - Turn off all electrical power to unit if service is to be performed.
- 3 - Remove access panel.
- 4 - Turn knob on Honeywell valve clockwise ➡ to **OFF**. Do not force.
- 5 - Replace access panel.

C-Safety or Emergency Shutdown

Turn off unit power. Close manual and main gas valves.

D-Extended Period Shutdown

Turn off thermostat or set to "UNOCCUPIED" mode. Close all gas valves (both internal and external to unit) to guarantee no gas leak into combustion chamber. Turn off power to unit. All access panels and covers must be in place and secured.

IV-HEATING SYSTEM SERVICE CHECKS

A-C.S.A. Certification

All units are C.S.A. (formally A.G.A. and C.G.A. combined) design certified without modifications. Refer to the G60DF Installation Instruction.

B-Gas Piping

⚠ CAUTION

If a flexible gas connector is required or allowed by the authority that has jurisdiction, black iron pipe shall be installed at the gas valve and extend outside the furnace cabinet.

⚠ WARNING

Do not exceed 600 in-lbs (50 ft-lbs) torque when attaching the gas piping to the gas valve.

Gas supply piping should not allow more than 0.5"W.C. drop in pressure between gas meter and unit. Supply gas pipe must not be smaller than unit gas connection.

Compounds used on gas piping threaded joints should be resistant to action of liquefied petroleum gases.

C-Testing Gas Piping

⚠ IMPORTANT

In case emergency shutdown is required, turn off the main shut-off valve and disconnect the main power to unit. These controls should be properly labeled by the installer.

When pressure testing gas lines, the gas valve must be disconnected and isolated. Gas valves can be damaged if subjected to more than 0.5psig (14" W.C.). See figure 14.

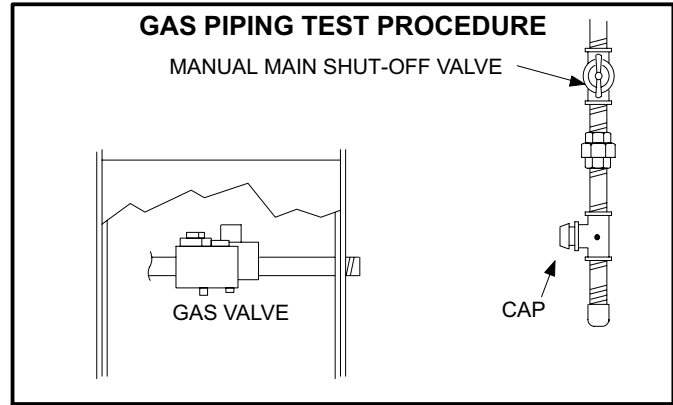

FIGURE 14

When checking piping connections for gas leaks, use preferred means. Kitchen detergents can cause harmful corrosion on various metals used in gas piping. Use of a specialty Gas Leak Detector is strongly recommended. It is available through Lennox under part number 31B2001. See Corp. 8411-L10, for further details.

Do not use matches, candles, flame or any other source of ignition to check for gas leaks.

D-Testing Gas Supply Pressure

When testing supply gas pressure, connect test gauge to inlet pressure tap on unit gas valve (GV1). See figure 13. Check gas line pressure with unit firing at maximum rate. Low pressure may result in erratic operation or underfire. High pressure can result in permanent damage to gas valve or overfire. See table 15 for operating pressure at unit gas connection (line).

On multiple unit installations, each unit should be checked separately, with and without units operating. Supply pressure must fall within range listed in table 15.

E-Check Manifold Pressure

After line pressure has been checked and adjusted, check manifold pressure. Move pressure gauge to outlet pressure tap located on unit gas valve (GV1). Checks of manifold pressure are made as verification of proper regulator adjustment. Manifold pressure can be measured at any time the gas valve is open and is supplying gas to the unit. See table 15 for normal operating manifold pressure. See HIGH ALTITUDE table (table of contents) for high altitude manifold pressures.

TABLE 15

All G60DF Units	Natural	LP
Line Pressure WC"	4.5 - 10.5	11.0 - 13.0
Manifold Pressure High Heat WC"	3.5	10.0
Manifold Pressure Low Heat WC"	1.7	4.9

⚠ IMPORTANT

For safety, connect a shut-off valve between the manometer and the gas tap to permit shut off of gas pressure to the manometer.

The gas valve is factory set and should not require adjustment. All gas valves are factory regulated.

Manifold Adjustment Procedure:

- 1 - Connect a test gauge to manifold pressure tap on gas valve. See figure or 13 for tap location. Start unit and allow 5 minutes for unit to reach steady state.
- 2 - While waiting for the unit to stabilize, notice the flame. Flame should be stable and should not lift from burner. Natural gas should burn blue. L.P. gas should burn mostly blue with some orange streaks.
- 3 - After allowing unit to stabilize for 5 minutes, record manifold pressure.

NOTE-Shut unit off and remove manometer as soon as an accurate reading has been obtained. Take care to replace pressure tap plug.

F- Proper Gas Flow (Approximate)

Furnace should operate at least 5 minutes before checking gas flow. Determine time in seconds for **two** revolutions of gas through the meter. (Two revolutions assures a more accurate time.) **Divide by two** and compare to time in table 16 below. If manifold pressure matches table 15 and rate is incorrect, check gas orifices for proper size and restriction.

NOTE- To obtain accurate reading, shut off all other gas appliances connected to meter.

TABLE 16

GAS METER CLOCKING CHART				
G60DF Unit	Seconds for One Revolution			
	Natural		LP	
	1 cu ft Dial	2 cu ft Dial	1 cu ft Dial	2 cu ft DIAL
-045	82	164	205	410
-70	55	110	136	272
-90	41	82	102	204
-110	33	66	82	164
-135	27	54	68	136
Natural-1000 btu/cu ft		LP-2500 btu/cu ft		

⚠ IMPORTANT

For safety, shut unit off and remove manometer as soon as an accurate reading has been obtained. Take care to replace pressure tap plug.

G- Proper Combustion

Furnace should operate minimum 15 minutes with correct manifold pressure and gas flow rate before checking combustion. See sections E- and F-. Take combustion sample beyond the flue outlet and compare to the tables below. The maximum carbon monoxide reading should not exceed 100 ppm.

**TABLE 17
High Heat**

Unit Btuh	CO₂% For Nat	CO₂% For L.P.
045	6.0 - 7.0	6.5 - 7.5
070	6.7 - 7.7	7.0 - 8.0
090	6.7 - 7.7	8.0 - 9.0
110	7.0 - 8.0	8.3 - 9.3
135	6.7 - 7.7	7.5 - 8.5

**TABLE 18
Low Heat**

Unit Btuh	CO₂% For Nat	CO₂% For L.P.
045	4.0 - 5.0	4.5 - 5.5
070	4.3 - 5.3	4.7 - 5.7
090	4.5 - 5.5	4.9 - 5.9
110	4.7 - 5.7	5.2 - 6.2
135	4.5 - 5.5	5.0 - 6.0

H-Flame Signal

A microamp DC meter is needed to check the flame signal on the ignition control.

Flame (microamp) signal is an electrical current which passes from the furnace control through the sensor during unit operation. Current passes from the sensor through the flame to ground to complete a safety circuit.

To Measure Flame Signal - Ignition Control:

A transducer (Part #78H5401 available from Lennox Repair Parts) is required to measure flame signal if meter used will not read a low micro amp signal.

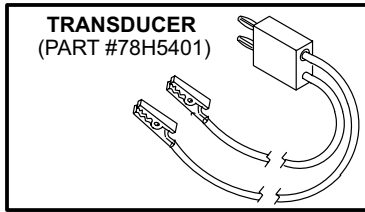

FIGURE 15

See figure 15. The transducer converts microamps to volts on a 1:1 conversion. See figures 10 and 11 for flame signal. A digital readout meter must be used. The transducer plugs into most meters. See figure 16 for proper use of transducer.

- 1 - Set the volt meter to the DC voltage scale. Insert transducer into the VDC and common inputs. Observe correct polarities. Failure to do so results in negative (-) values.
- 2 - Turn off supply voltage to control.
- 3 - Disconnect ignition control flame sensor wire from the flame sensor.
- 4 - Connect (-) lead of the transducer to flame sensor.
- 5 - Connect (+) lead of transducer to the ignition control sensor wire.
- 6 - Turn supply voltage on and close thermostat contacts to cycle system.
- 7 - When main burners are in operation for two minutes, take reading. Remember 1 DC volt = 1 DC microamp.

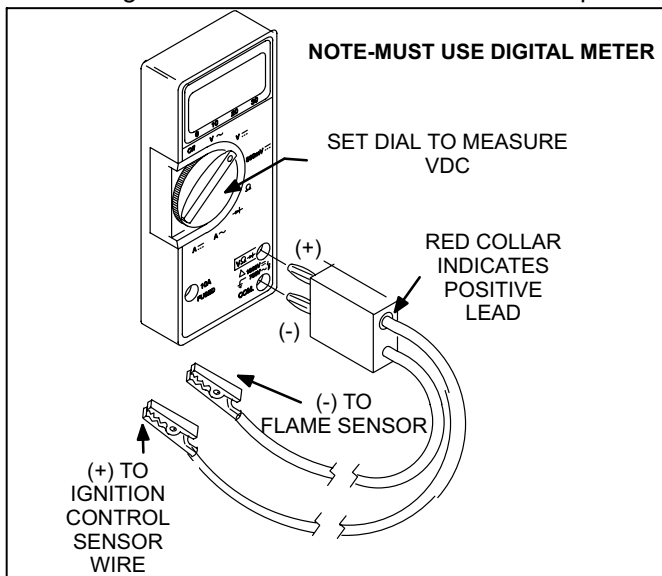

FIGURE 16

V-TYPICAL OPERATING CHARACTERISTICS

A-Blower Operation and Adjustment

- 1 - Blower operation is dependent on thermostat control system.
- 2 - Generally, blower operation is set at thermostat sub-base fan switch. With fan switch in ON position, blower operates continuously. With fan switch in AUTO position, blower cycles with demand or runs continuously while heating or cooling circuit cycles.
- 3 - Depending on the type of indoor thermostat, blower and entire unit will be off when the system switch is in OFF position.

B-Temperature Rise

Temperature rise for G60DF units depends on unit input, blower speed, blower horsepower and static pressure as marked on the unit rating plate. The blower speed must be set for unit operation within the range of "TEMP. RISE °F" listed on the unit rating plate.

To Measure Temperature Rise:

- 1 - Place plenum thermometers in the supply and return air plenums. Locate supply air thermometer in the first horizontal run of the plenum where it will not pick up radiant heat from the heat exchanger.
- 2 - Set thermostat to highest setting.
- 3 - After plenum thermometers have reached their highest and steadiest readings, subtract the two readings. The difference should be in the range listed on the unit rating plate. If the temperature is too low, decrease blower speed. If temperature is too high, first check the firing rate. Provided the firing rate is acceptable, increase blower speed to reduce temperature. To change blower speed taps see the Blower Speed Taps section in this manual.

C-External Static Pressure

- 1 - Tap locations shown in figure 17.
- 2 - Punch a 1/4" diameter hole in supply and return air plenums. Insert manometer hose flush with inside edge of hole or insulation. Seal around the hose with perma-gum. Connect the zero end of the manometer to the discharge (supply) side of the system. On ducted systems, connect the other end of manometer to the return duct as above. For systems with non-ducted returns, leave the other end of the manometer open to the atmosphere.
- 3 - With only the blower motor running and the evaporator coil dry, observe the manometer reading. Adjust blower motor speed to deliver the air desired according to the job requirements.
- 4 - External static pressure drop must not be more than 0.5" W.C.
- 5 - Seal around the hole when the check is complete.

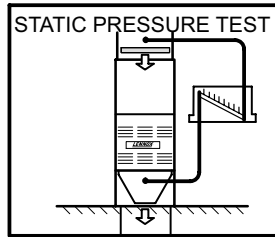

FIGURE 17

D-Blower Speed Taps

Blower speed tap changes are made on the SureLight control board. See figure 4. The unused tap must be secured on dummy terminals "PARK" on the SureLight board. The high heating tap is connected to the "HI HEAT" terminal and the low heating / continuous blower tap is connected to the "LO HEAT" terminal. The cooling tap is connected to the "COOL" tap.

To change existing heat tap, turn off power then switch out speed tap on "HI HEAT" or "LO HEAT" with tap connected to "PARK". See table 19 for blower motor tap colors for each speed.

TABLE 19

BLOWER SPEED CHART					
UNIT	FACTORY CONNECTED SPEED TAPS				MOTOR SPEEDS AVAIL.
	COOL	HI HEAT	LO HEAT	PARK	
* 24A-045	BLACK	RED	RED	YELLOW	3
36A-070		YELLOW	RED	BROWN	4
36B-090		YELLOW	RED	BROWN	4
48C-090		YELLOW	RED	BROWN	4
48C-110		YELLOW	RED	BROWN	4
60C-110		YELLOW	RED	BROWN	4
60D-135		YELLOW	RED	BROWN	4
BLOWER SPEED SELECTION					
HI ← → LO					
SPEED TAPS	BLACK	YELLOW	RED		3
	BLACK	BROWN	YELLOW	RED	4

* On G60DF-045 only, jumper wire between HI and LO heat is factory provided.

VI-MAINTENANCE

⚠ WARNING

Disconnect power before servicing unit.

⚠ CAUTION

Label all wires prior to disconnection when servicing controls. Wiring errors can cause improper and dangerous operation. Verify proper operation after servicing.

At the beginning of each heating season, a qualified technician should check the system as follows:

A-Blower

Check the blower wheel for debris and clean if necessary. The blower motors are prelubricated for extended bearing life. No further lubrication is needed.

⚠ WARNING

The blower access panel and vent pipe must be securely in place when the blower and burners are operating. Gas fumes, which could contain carbon monoxide, can be drawn into living space resulting in personal injury or death.

B-Filters

All filters are installed external to the unit. Filters should be inspected monthly. Clean or replace the filters when necessary to ensure that the furnace operates properly. Replacement filters must be rated for high velocity airflow.

C-Flue and Chimney

Check the flue pipe, chimney and all connections for tightness and to make sure there is no blockage.

D-Electrical

- 1 - Check all wiring for loose connections.
- 2 - Check for the correct voltage at the furnace (furnace operating).
- 3 - Check amp-draw on the blower motor.
Motor Nameplate _____ Actual _____

E-Heat Exchanger and Burners

NOTE - Use papers or protective covering in front of the furnace during cleaning.

Cleaning the heat exchanger requires a steel spring "snake," a reversible drill and a vacuum cleaner. The steel spring snake may be constructed using a 4 ft. long by 1/4 inch diameter steel wire cable and a 1/4 inch diameter wire brush. These items are available at a hardware store. Insert wire end of brush into the open end of the spring cable. Crimp the cable around the brush so that the brush is secured and will not come off during cleaning. Attach the other end of the cable to the reversible drill to complete the tool for cleaning the heat exchanger.

- 1 - Turn off both electrical and gas supplies to the furnace. Remove the furnace access panels.

- 2 - Remove the three screws that secure the vent pipe to the flue collar.
- 3 - Remove the screw that secures the internal flue pipe to the combustion air inducer. See figure 18.
- 4 - Scrape away the silicone sealant that is between the internal flue pipe and the combustion air inducer.
- 5 - Pull the internal flue pipe into the chase.
- 6 - Label and disconnect the pressure switch wires.
- 7 - Remove the four screws that secure the combustion air inducer. Carefully remove the combustion air inducer to avoid damaging the blower gasket. If the gasket is damaged, it must be replaced to prevent leakage. See figure 20.
- 8 - Remove the collector box located behind the combustion air inducer. Be careful with the collector box gasket. If the gasket is damaged, it must be replaced to prevent leakage.
- 9 - Label the wires from gas valve and rollout switches, then disconnect them.
- 10 - Disconnect gas supply piping. Remove four screws securing the burner manifold assembly to the vestibule panel and remove the assembly from the unit.
- 11 - ***NO_x units only*** - Remove the three screws that attach the **NO_x** insert to the corbel at the entrance to each heat exchanger section. Carefully remove the **NO_x** insert from each section. See figure 19.

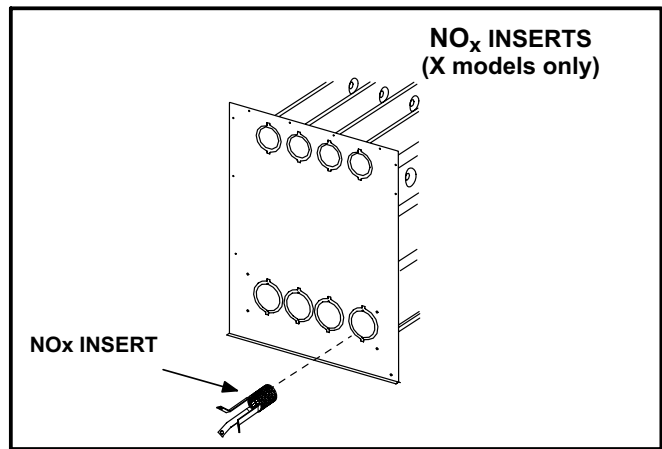

FIGURE 19

- 12 - Insert the brush end of cable snake into the top of one of the heat exchanger openings. **Do not force the cable into the heat exchanger.** Insert the cable and operate the drill on slow speed. Move the cable in and out of the heat exchanger section three or four times or until sufficient cleaning is accomplished. Reverse drill and slowly work the cable out of opening.
- 13 - Repeat procedure for each heat exchanger section.
- 14 - After each of the top heat exchanger sections has been cleaned, insert the brush end of the cable snake into the bottom openings of each of the heat exchanger sections and clean as described in step 12.
- 15 - Remove the cable from the heat exchanger. Use a vacuum cleaner to remove debris knocked loose during cleaning.

NOTE - Take care not to inhale loose debris and avoid eye contact. Safety glasses and surgical mask should be worn when using vacuum cleaner.

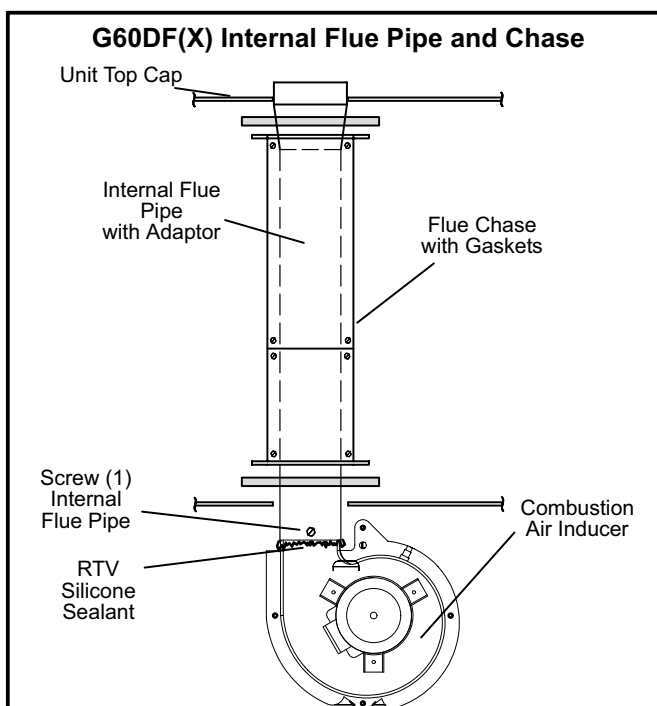

FIGURE 18

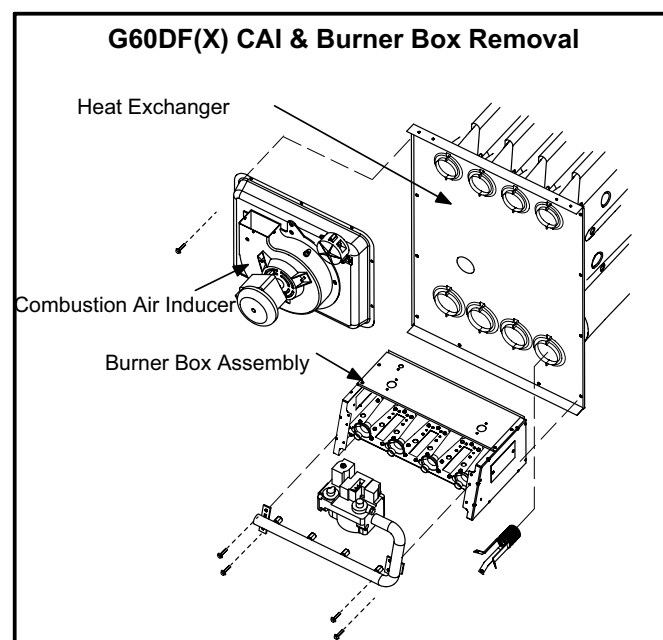

FIGURE 20

- 16 -Attach the exhaust end (positive pressure) of the vacuum cleaner to the top of the heat exchanger section. Any loose debris will be forced to the bottom of the heat exchanger section. Vacuum debris from bottom openings.
- 17 -Replace collector box and combustion air inducer. Check gaskets for damage. Damaged gaskets must be replaced to avoid heat exchanger leaks. Replace all screws to the collector box and combustion air inducer. Failure to replace all screws may cause leaks.
- 18 -To clean the burner, run a vacuum cleaner with a soft brush attachment over the face of burners. Inspect inside the burners and crossovers for any blockage. Clean the inside of the burner if necessary.
- 19 -**NO_x Units** - Reattach the NO_x inserts to the corbels at the entrance to each heat exchanger opening. See figure 19.
- 20 -Reinstall the burner/manifold assembly on the vestibule panel.
- 21 -Reconnect wires to pressure switch, roll-out switches, gas valve and combustion air inducer. Refer to unit wiring diagram.
- 22 -Use screws to resecure the junction box to the cabinet.
- 23 -Apply RTV/high temperature silicone sealant between the internal flue pipe and the combustion air inducer.
- 24 -Use one screw to resecure the internal flue pipe to the combustion air inducer.

- 25 -Use three screws to resecure the vent pipe to the flue collar.

WARNING

The blower access panel and vent pipe must be securely in place when the blower and burners are operating. Gas fumes, which could contain carbon monoxide, can be drawn into living space resulting in personal injury or death.

- 26 -Reconnect the gas supply piping.
- 27 -Turn on power and gas supply to the unit.
- 28 -Set thermostat and check for proper operation.
- 29 -Check all piping connections, factory and field, for gas leaks. Use a leak detecting solution or other preferred means.

CAUTION

Some soaps used for leak detection are corrosive to certain metals. Carefully rinse piping thoroughly after leak test has been completed. Do not use matches, candles, flame or other sources of ignition to check for gas leaks.

- 30 -If a leak is detected, shut gas and electricity off and repair leak.
- 31 -Replace front access panels.

B-G60DF-4, -5 with SureLight Board 18M34

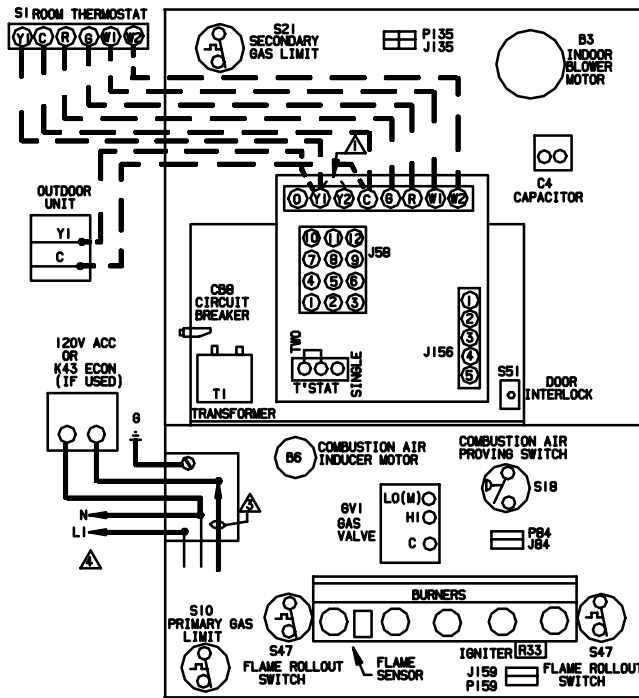

BLOWER SPEED CHART					
UNIT	FACTORY CONNECTED SPEED TAPS				MOTOR SPEEDS AVAIL.
	COOL	HI HEAT	LO HEAT	PARK	
36A-070	Y	YELLOW	RED	BROWN	4
36B-090	Y	YELLOW	RED	BROWN	4
48C-110	Y	YELLOW	RED	BROWN	4

BLOWER SPEED SELECTION				
SPEED TAPS	BLACK	BROWN	YELLOW	RED
HI			LO	
LO				4

JACKPLUG CHART	
J.P58	JACK/PLUG-IGNITION CONTROL
J.P84	JACK/PLUG-COMB. AIR INDUCER
J.P156	JACK/PLUG-SECONDARY LIMIT
J.P159	JACK/PLUG-INDUCER/IGNITER
J.P159	JACK/PLUG-IGNITER

THERMOSTAT HEAT ANTICIPATION SETTINGS
 .65 AMP HONEYWELL VALVE

- ⚠️ Y1 TO Y2 JUMPER FACTORY INSTALLED. LEAVE IN FOR ONE STAGE COOL THERMOSTAT. REMOVE JUMPER Y1 TO Y2 FOR TWO STAGE COOL THERMOSTAT.
- ⚠️ FACTORY DEFAULT IS FOR A 2 STAGE THERMOSTAT
- ⚠️ FIELD SUPPLIED ACC WIRE
- ⚠️ USE COPPER CONDUCTORS ONLY
- ⚠️ IMPORTANT - TO PREVENT MOTOR BURNOUT, NEVER CONNECT MORE THAN ONE MOTOR LEAD TO ANY ONE CONNECTION.
- ⚠️ PARK TERMINAL IS A UNPOWERED TERMINAL. ALL UNUSED MOTOR LEADS MUST BE WIRED TO THE PARK TERMINAL.

— LINE VOLTAGE FIELD INSTALLED
 - - - CLASS II VOLTAGE FIELD WIRING
 ⚠️ DENOTES OPTIONAL COMPONENTS

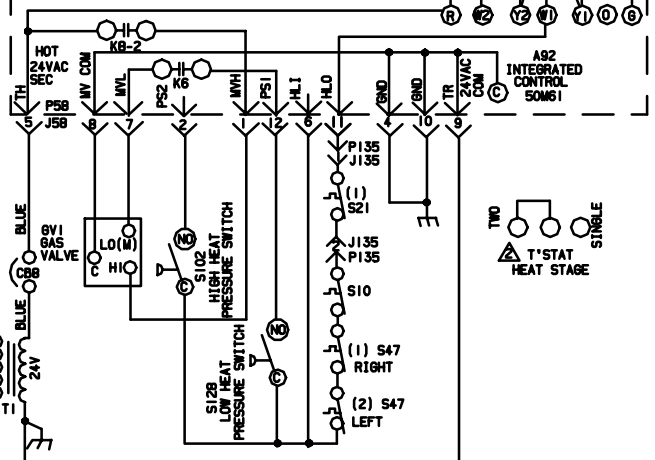
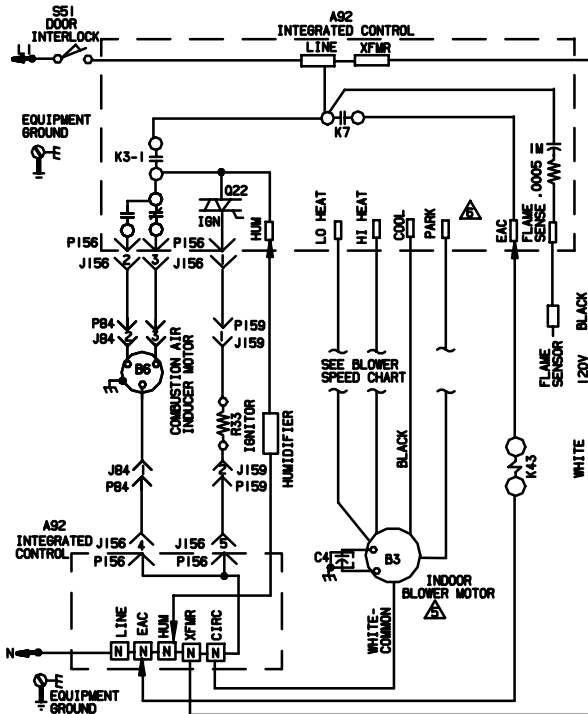
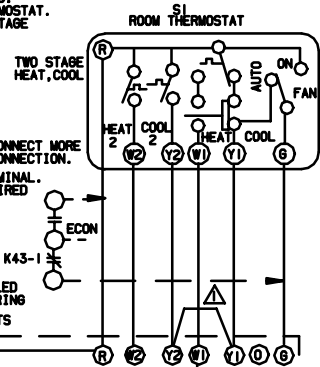

WARNING-
 ELECTRIC SHOCK HAZARD, CAN CAUSE INJURY OR DEATH. UNIT MUST BE GROUNDED IN ACCORDANCE WITH NATIONAL AND LOCAL CODES.

IF ANY WIRE IN THIS APPLIANCE IS REPLACED, IT MUST BE REPLACED WITH WIRE OF LIKE SIZE, RATING, INSULATION THICKNESS, AND TERMINATION.

LENOX HEATING UNITS-GAS	
660DF-36A-070-4, 5	
660DF-36B-090-4, 5	
660DF-48C-110-4, 5	
0903	Supersedes 534, 437W
	New Form No. 534, 548W

©2008 Lennox Industries Inc.

Li the U.S.A.

G60DF Units with SureLight Board 18M34

Sequence depends on type thermostat used. Units are applicable for single stage or two stage thermostats. Both type thermostats are described below. Thermostat jumper E20 dictates which mode unit will operate in. See flow chart for more sequence detail.

SureLight Control Self Check

When there is a call for heat, the SureLight integrated control runs a self check. The control checks for S10 primary limit, S21 secondary limit (s) and S47 rollout switch normally closed contacts. The control also checks for S102 high heat and S128 low heat prove switch normally open contacts. Once self check is complete and all safety switches are operational, heat call can continue.

Two-Stage Thermostat, Two Stage Heat. Jumper E20 set at "TWO".

- 1- SureLight control energizes combustion air inducer B6 on low heat speed. Combustion air inducer runs until S128 low heat prove switch contacts close (switch must close within 2 1/2 minutes or control goes into Watchguard Pressure Switch mode. High heat prove switch S102 may also close). A 15 second pre-purge follows once S128 closes.
- 2- SureLight control begins 20 second ignitor warm up period.
- 3- Gas valve opens on first stage for a 4 second trial for ignition. Ignitor stays energized during the trial or until flame sensed.
- 4- Flame is sensed, gas valve remains on first stage heat, ignitor de-energizes.
- 5- After 45 second delay, indoor blower B3 is energized on low heat speed.
The furnace will stay in this mode until first stage demand is satisfied OR a second stage heat demand is initiated.
- 6- Second stage heat demand initiated. A 30 second second stage recognition period begins.
- 7- The combustion air inducer ramps up to high heat speed.
- 8- S102 high heat prove switch closes and the gas valve energizes second stage heat.
- 9- B3 indoor blower ramps up to high heat speed.

Single-Stage Thermostat, Two Stage Heat. Jumper E20 set at "SINGLE"

- 1- SureLight control energizes combustion air inducer B6 on low heat speed. Combustion air inducer runs until S128 low heat prove switch contacts close (switch must close within 2 1/2 minutes or control goes into Watchguard Pressure Switch mode. High heat prove switch S102 may also close). A 15 second pre-purge follows once S128 closes.
- 2- SureLight control begins 20 second ignitor warm up period.
- 3- Gas valve opens on first stage for a 4 second trial for ignition. Ignitor stays energized during the trial or until flame sensed.
- 4- Flame is sensed, gas valve remains on first stage heat, ignitor de-energizes.
- 5- After 45 second delay, indoor blower B3 is energized on low heat speed.
- 6- A 10 minute (factory set) or 15 minute (field set) second stage heat delay period begins.
- 7- The combustion air inducer ramps up to high heat speed.
- 8- S102 high heat prove switch closes and the gas valve energizes second stage heat.
- 9- B3 indoor blower ramps up to high heat speed.

G60DF Units with SureLight Board 18M34

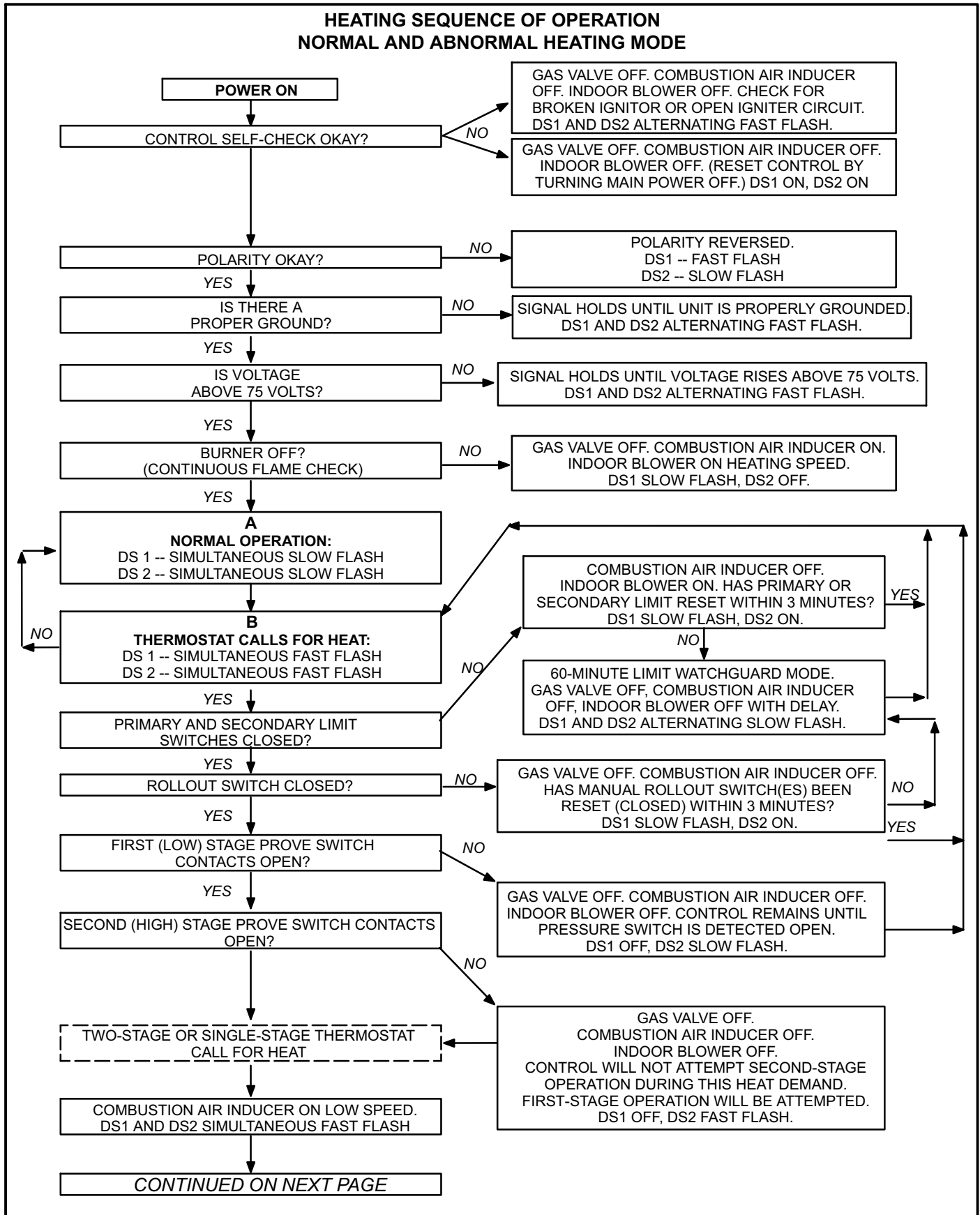

HEATING SEQUENCE OF OPERATION

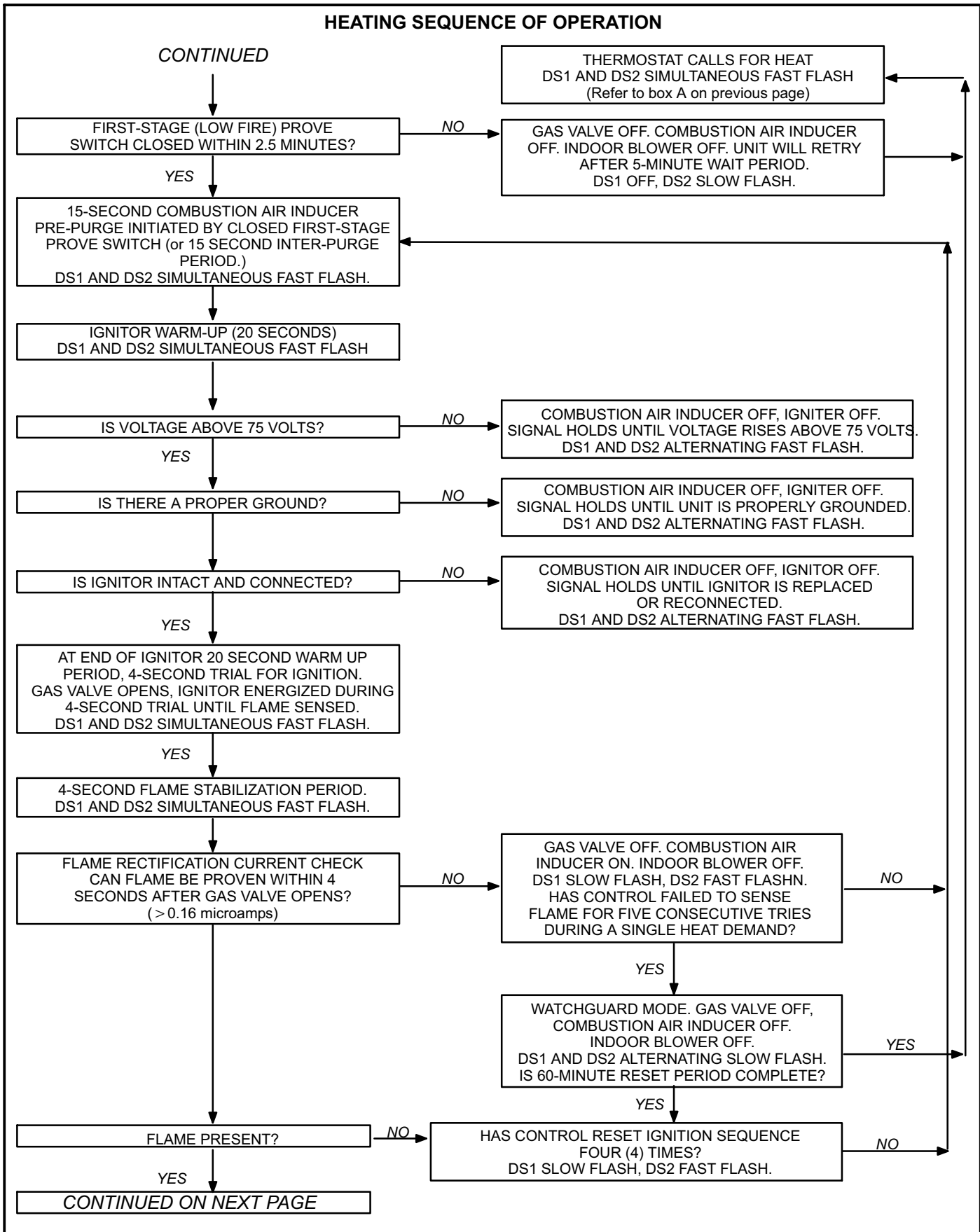

HEATING SEQUENCE OF OPERATION

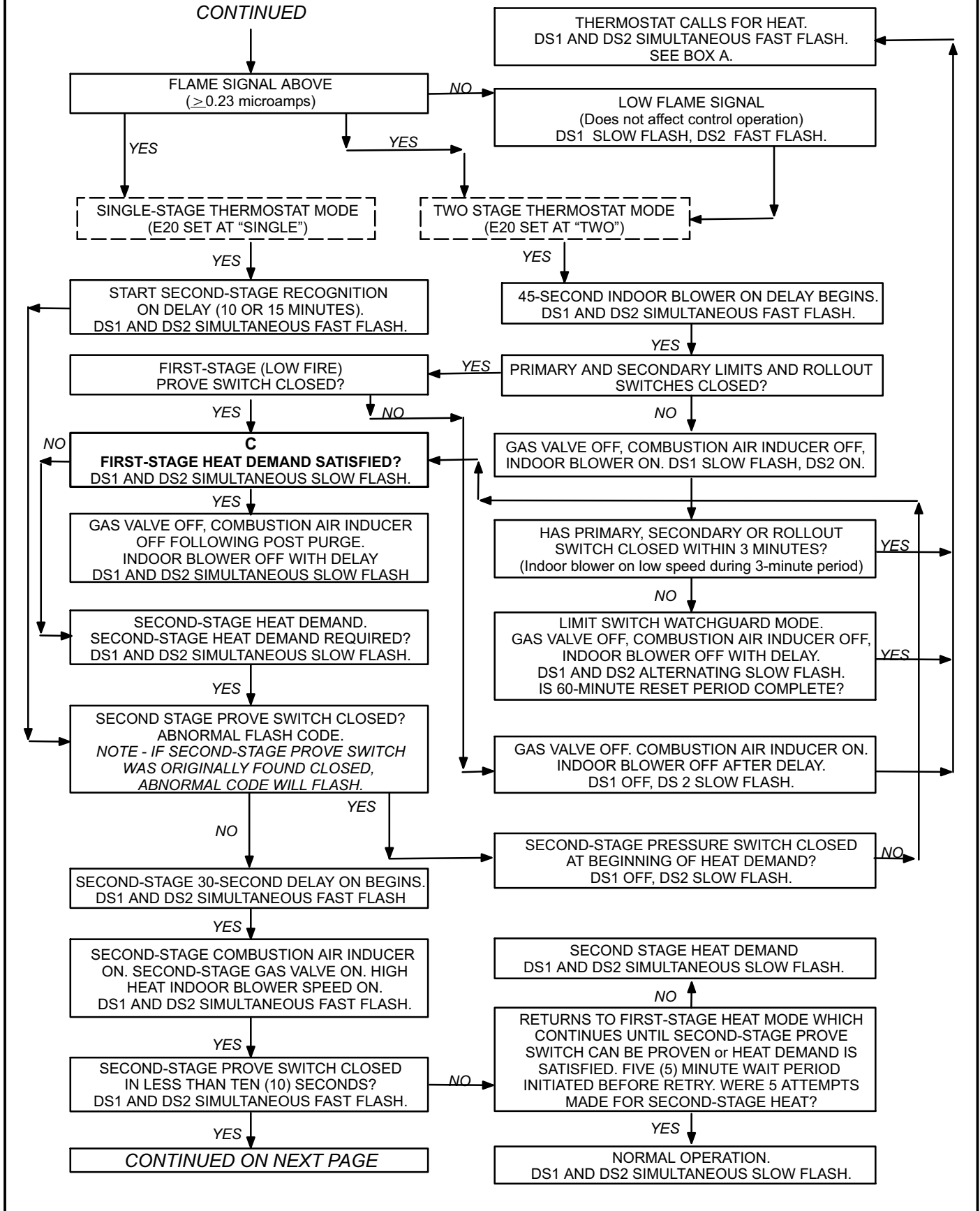

HEATING SEQUENCE OF OPERATION

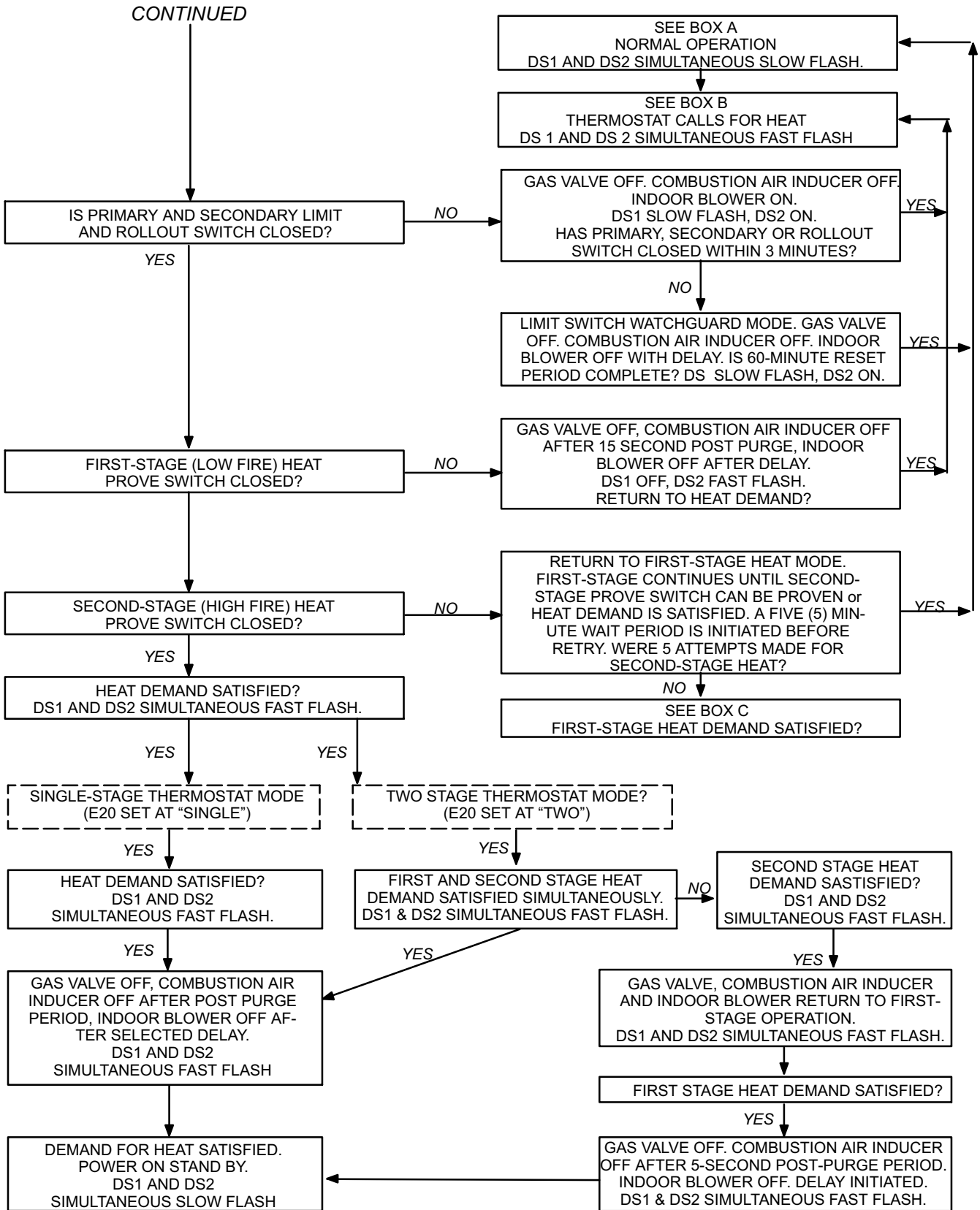

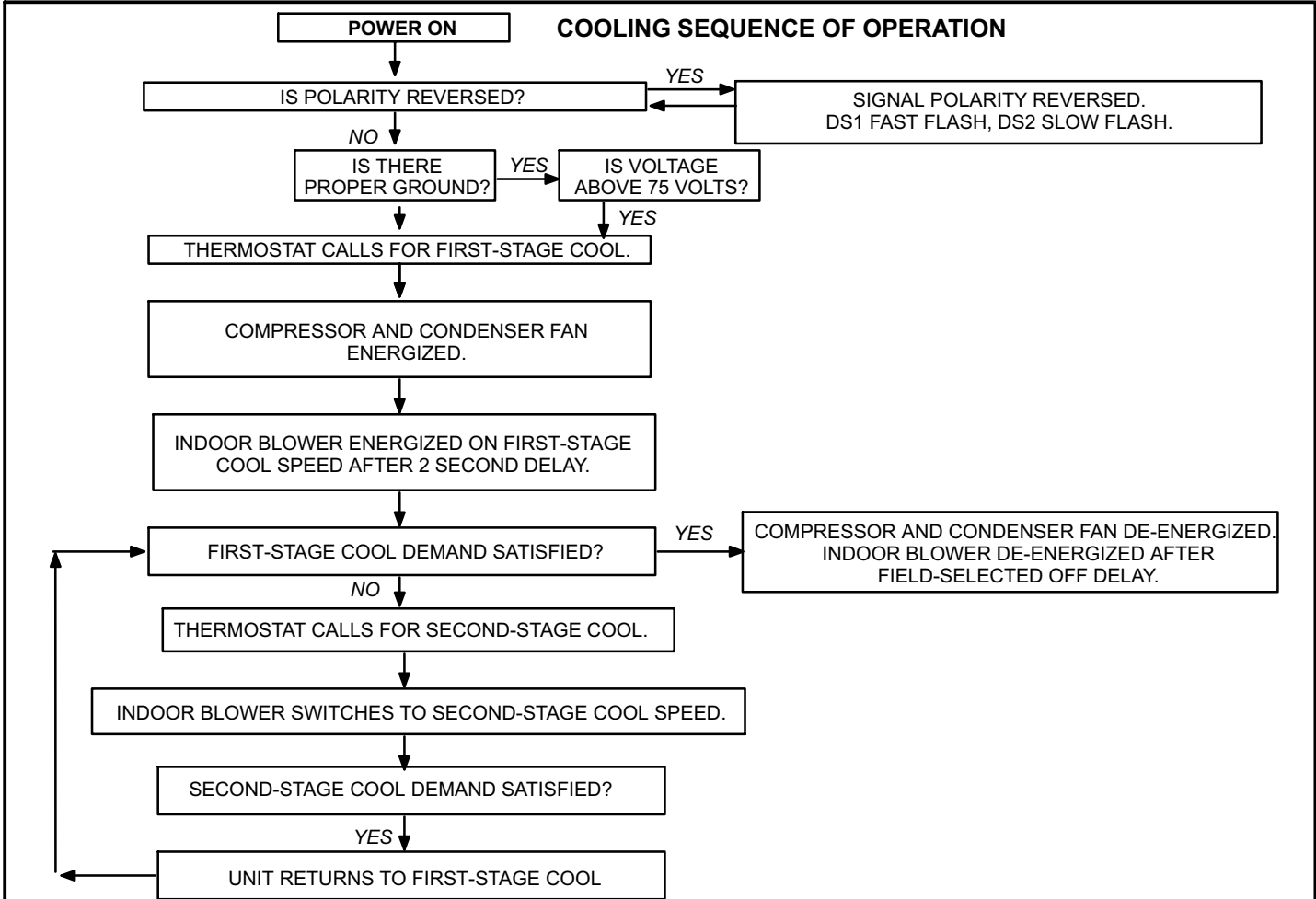

CONTINUOUS LOW SPEED FAN SEQUENCE OF OPERATION

NOTE - Continuous low speed fan and cooling low speed are equal to the low heat fan speed.

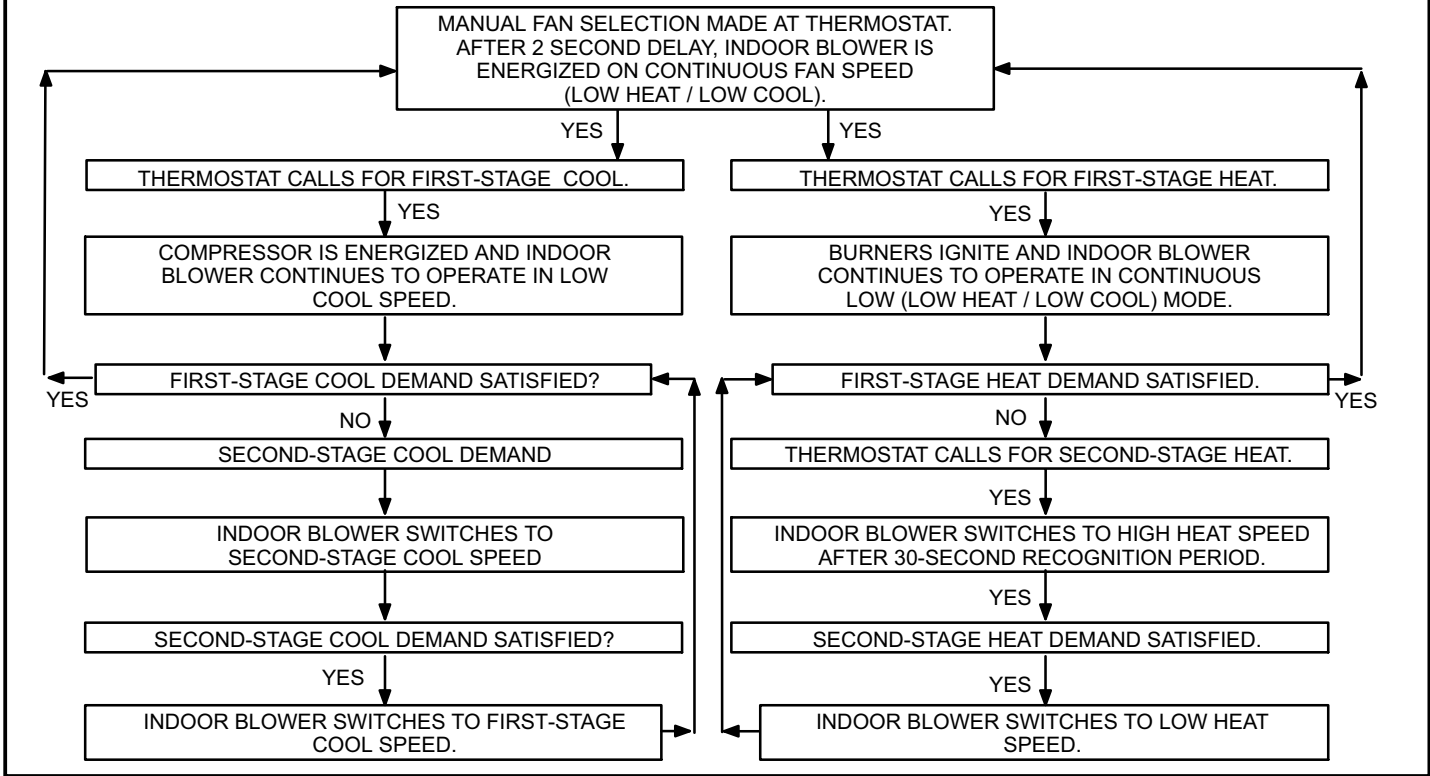

C-G60DF Units with SureLight Board 100869

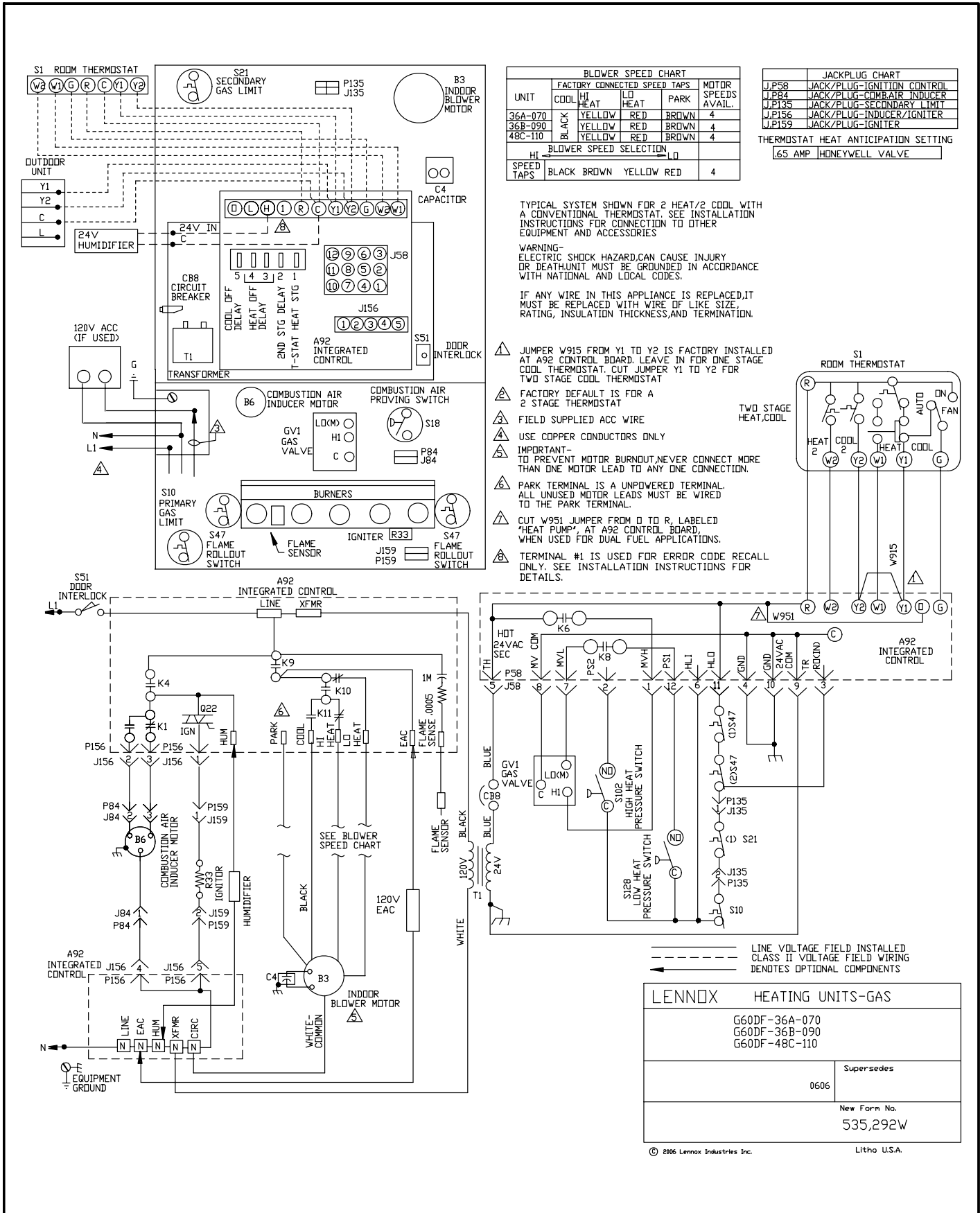

BLOWER SPEED CHART					
UNIT	FACTORY CONNECTED SPEED TAPS				MOTOR SPEEDS AVAILABLE
	COOL	HI HEAT	LO HEAT	PARK	
36A-070	BLACK	YELLOW	RED	BROWN	4
36B-090	BLACK	YELLOW	RED	BROWN	4
48C-110	BLACK	YELLOW	RED	BROWN	4

HI	LO
BLOWER SPEED SELECTION	
SPEED TAPS	BLACK BROWN YELLOW RED
	4

JACKPLUG CHART	
J.P58	JACK/PLUG-IGNITION CONTROL
J.P84	JACK/PLUG-COMB AIR INDUCER
J.P135	JACK/PLUG-SECONDARY LIMIT
J.P156	JACK/PLUG-INDUCER/IGNITER
J.P159	JACK/PLUG-IGNITER

TERMOSTAT HEAT ANTICIPATION SETTING	1.65 AMP HONEYWELL VALVE
-------------------------------------	--------------------------

TYPICAL SYSTEM SHOWN FOR 2 HEAT/2 COOL WITH A CONVENTIONAL THERMOSTAT. SEE INSTALLATION INSTRUCTIONS FOR CONNECTION TO OTHER EQUIPMENT AND ACCESSORIES.

WARNING: ELECTRIC SHOCK HAZARD, CAN CAUSE INJURY OR DEATH. UNIT MUST BE GROUNDED IN ACCORDANCE WITH NATIONAL AND LOCAL CODES.

IF ANY WIRE IN THIS APPLIANCE IS REPLACED, IT MUST BE REPLACED WITH WIRE OF LIKE SIZE, RATING, INSULATION THICKNESS, AND TERMINATION.

- ⚠️ JUMPER W915 FROM Y1 TO Y2 IS FACTORY INSTALLED AT A92 CONTROL BOARD. LEAVE IN FOR ONE STAGE COOL THERMOSTAT. CUT JUMPER Y1 TO Y2 FOR TWO STAGE COOL THERMOSTAT
- ⚠️ FACTORY DEFAULT IS FOR A 2 STAGE THERMOSTAT
- ⚠️ FIELD SUPPLIED ACC WIRE
- ⚠️ USE COPPER CONDUCTORS ONLY
- ⚠️ IMPORTANT - TO PREVENT MOTOR BURNOUT, NEVER CONNECT MORE THAN ONE MOTOR LEAD TO ANY ONE CONNECTION.
- ⚠️ PARK TERMINAL IS A UNPOWERED TERMINAL. ALL UNUSED MOTOR LEADS MUST BE WIRED TO THE PARK TERMINAL.
- ⚠️ CUT W951 JUMPER FROM D TO R, LABELED 'HEAT PUMP', AT A92 CONTROL BOARD, WHEN USED FOR DUAL FUEL APPLICATIONS.
- ⚠️ TERMINAL #1 IS USED FOR ERROR CODE RECALL ONLY. SEE INSTALLATION INSTRUCTIONS FOR DETAILS.

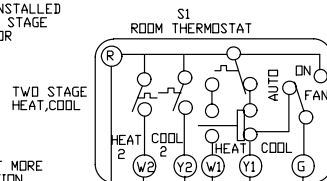

— LINE VOLTAGE FIELD INSTALLED
 - - - CLASS II VOLTAGE FIELD WIRING
 DENOTES OPTIONAL COMPONENTS

LENNOX HEATING UNITS-GAS	
G60DF-36A-070 G60DF-36B-090 G60DF-48C-110	
Supersedes	
0606	
New Form No. 535,292W	

G60DF Units with SureLight Board 100869

Sequence depends on type thermostat used. G060DF units are applicable for single stage or two stage thermostats. Both type thermostats are described below. Thermostat dip switch selection dictates which mode unit will operate in. See flow chart for more sequence detail.

SureLight Control Self Check

When there is a call for heat, the SureLight integrated control runs a self check. The control checks for S10 primary limit, S21 secondary limit (s) and S47 rollout switch normally closed contacts. The control also checks for S102 high heat and S128 low heat prove switch normally open contacts. Once self check is complete and all safety switches are operational, heat call can continue.

Two-Stage Thermostat, Two Stage Heat. Dip Switch set at "TWO".

- 1- SureLight control energizes combustion air inducer B6 on low heat speed. Combustion air inducer runs until S128 low heat prove switch contacts close (switch must close within 2 1/2 minutes or control goes into Watchguard Pressure Switch mode. High heat prove switch S102 may also close). A 15 second pre-purge follows once S128 closes.
- 2- SureLight control begins 20 second ignitor warm up period.
- 3- Gas valve opens on first stage for a 4 second trial for ignition. Ignitor stays energized during the trial or until flame sensed.
- 4- Flame is sensed, gas valve remains on first stage heat, ignitor de-energizes.
- 5- After 45 second delay, indoor blower B3 is energized on low heat speed.
The furnace will stay in this mode until first stage demand is satisfied OR a second stage heat demand is initiated.
- 6- Second stage heat demand initiated. A 30 second second stage recognition period begins.
- 7- The combustion air inducer ramps up to high heat speed.
- 8- S102 high heat prove switch closes and the gas valve energizes second stage heat.
- 9- B3 indoor blower switches to high heat speed.

Single-Stage Thermostat, Two Stage Heat. Dip Switch set at "SINGLE"

- 1- SureLight control energizes combustion air inducer B6 on low heat speed. Combustion air inducer runs until S128 low heat prove switch contacts close (switch must close within 2 1/2 minutes or control goes into Watchguard Pressure Switch mode. High heat prove switch S102 may also close). A 15 second pre-purge follows once S128 closes.
- 2- SureLight control begins 20 second ignitor warm up period.
- 3- Gas valve opens on first stage for a 4 second trial for ignition. Ignitor stays energized during the trial or until flame sensed.
- 4- Flame is sensed, gas valve remains on first stage heat, ignitor de-energizes.
- 5- After 45 second delay, indoor blower B3 is energized on low heat speed.
- 6- A 10 minute (factory set) or 15 minute (field set) second stage heat delay period begins.
- 7- After the delay the combustion air inducer ramps up to high heat speed.
- 8- S102 high heat prove switch closes and the gas valve energizes second stage heat.
- 9- B3 indoor blower switches to high heat speed.

G60DF Units with SureLight Board 100869

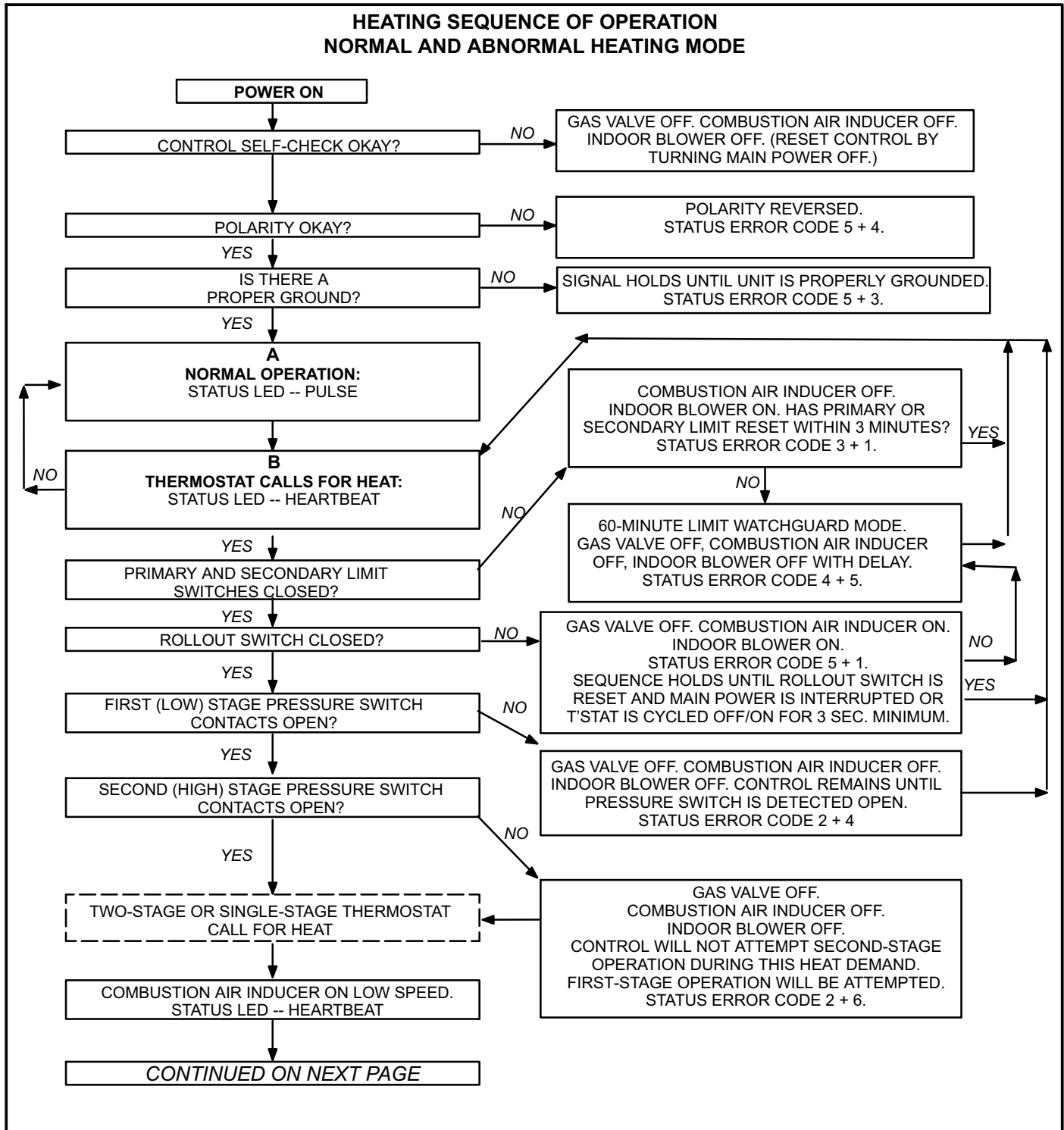

HEATING SEQUENCE OF OPERATION

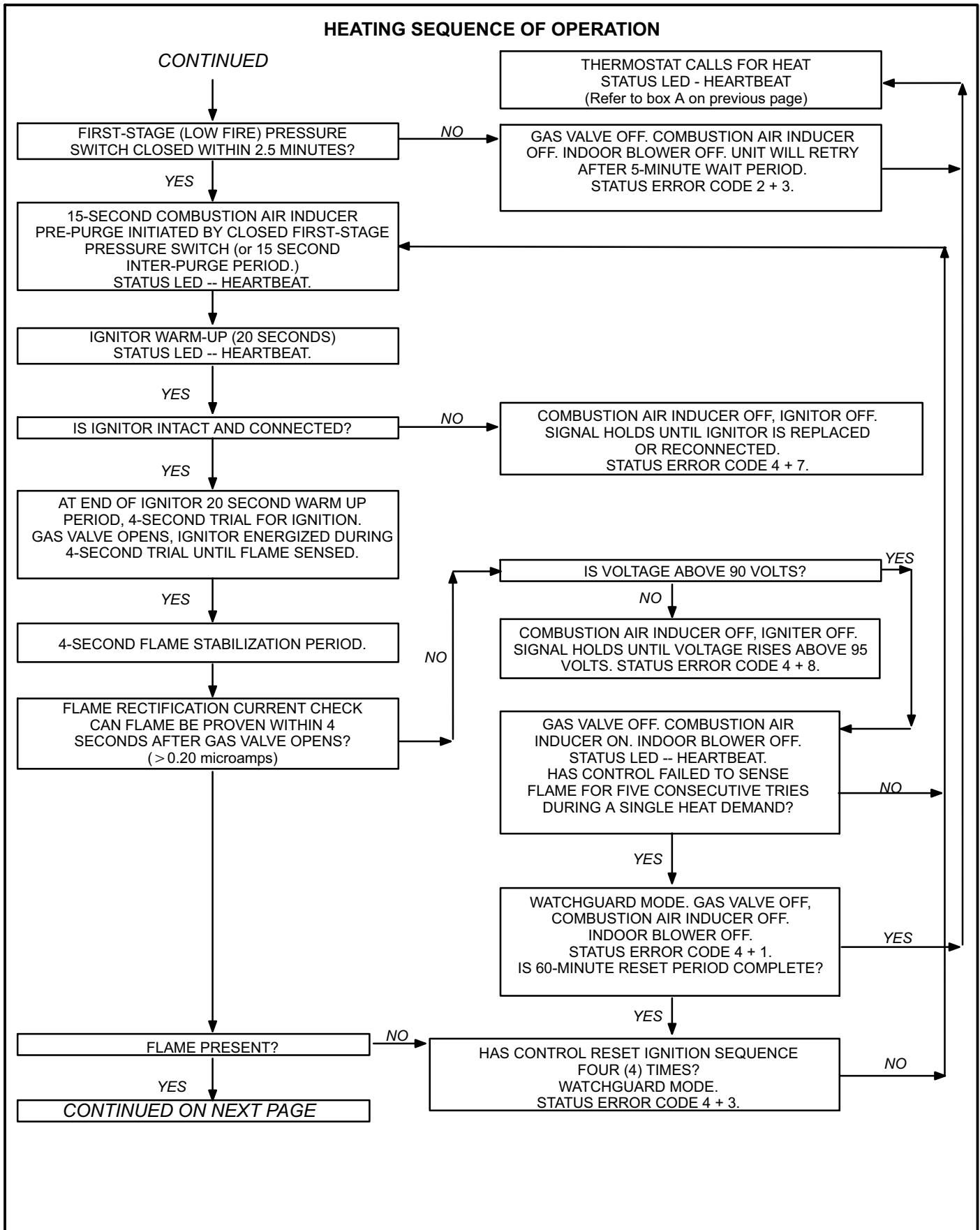

HEATING SEQUENCE OF OPERATION

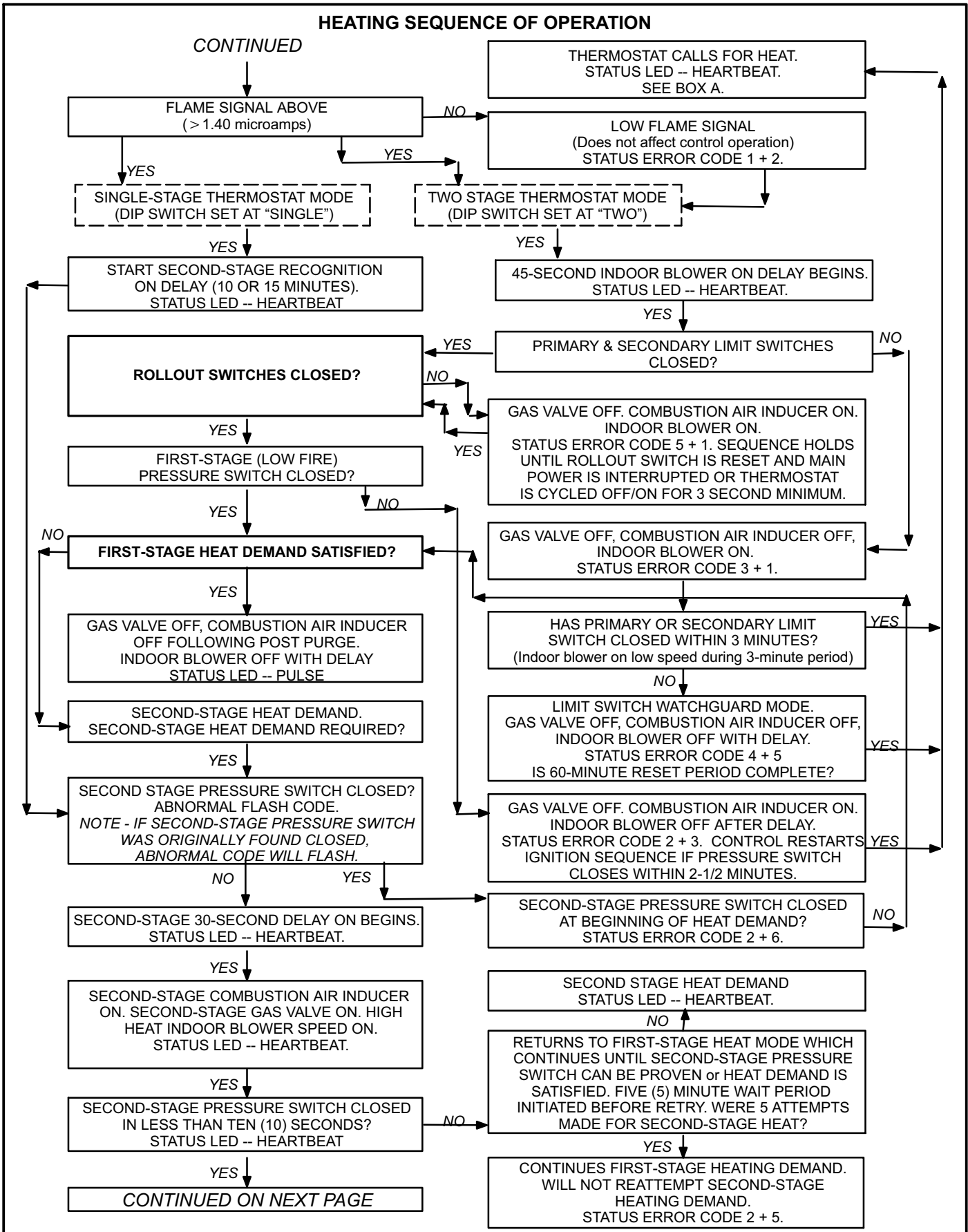

HEATING SEQUENCE OF OPERATION

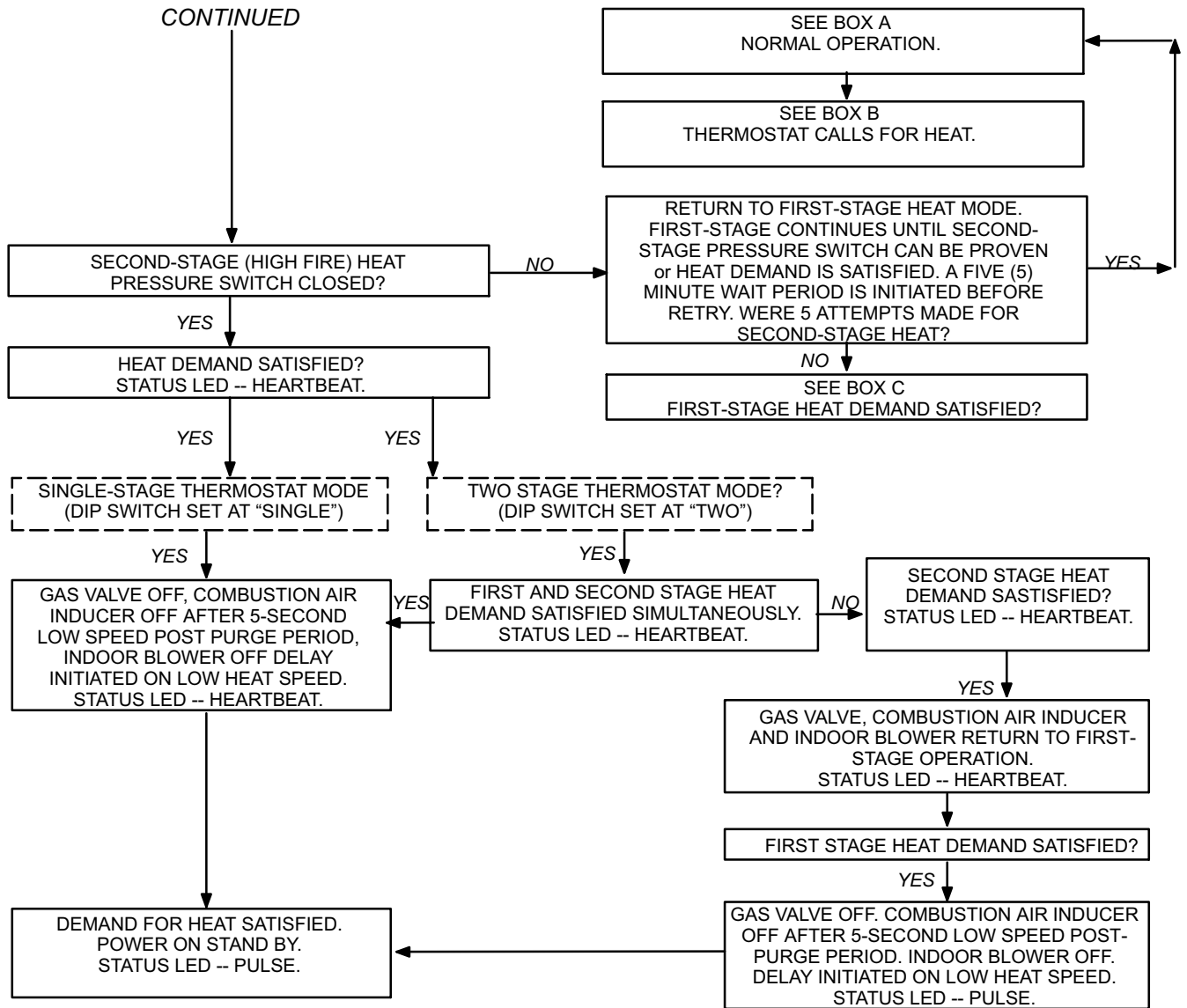

COOLING SEQUENCE OF OPERATION

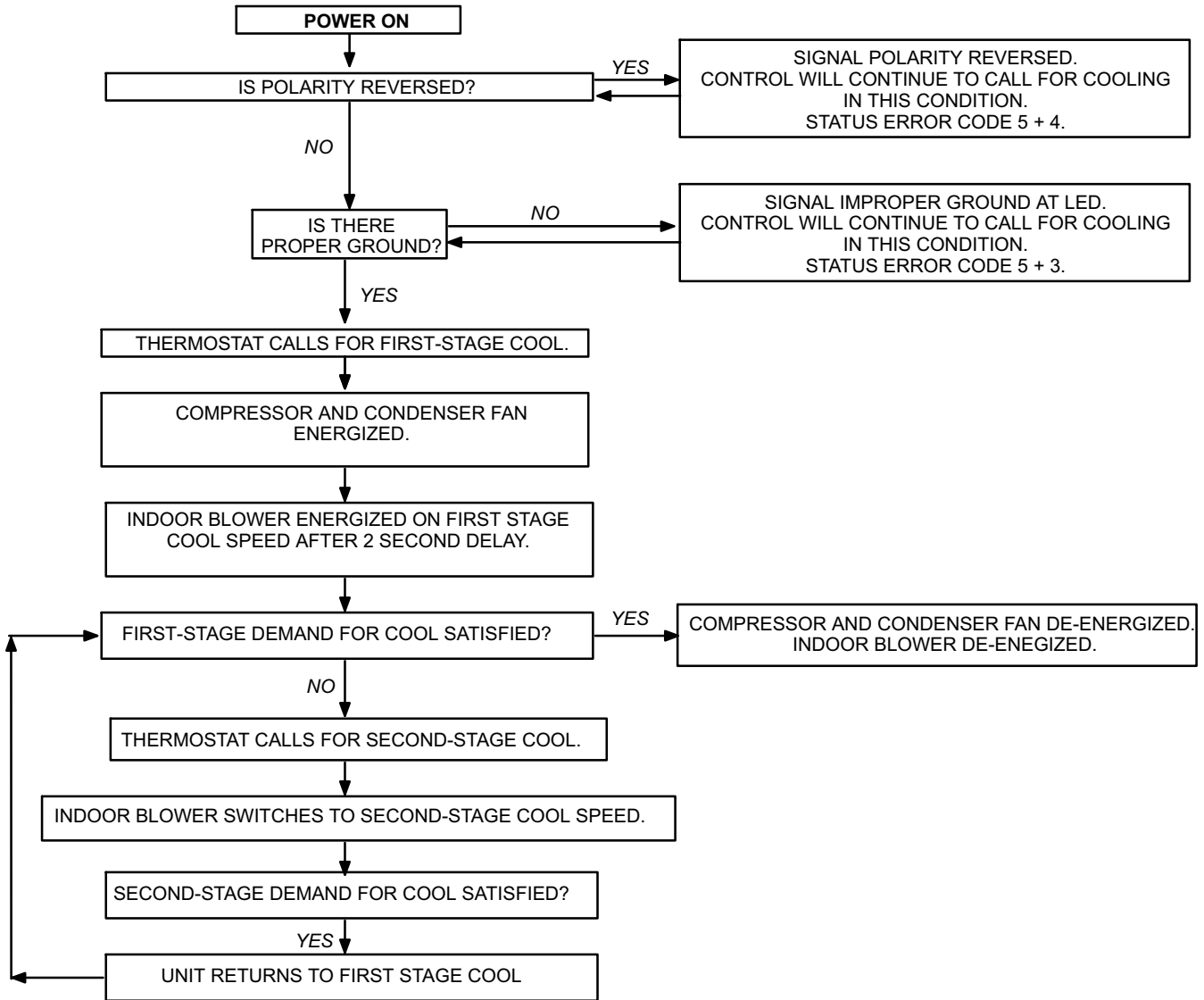

CONTINUOUS LOW SPEED FAN SEQUENCE OF OPERATION

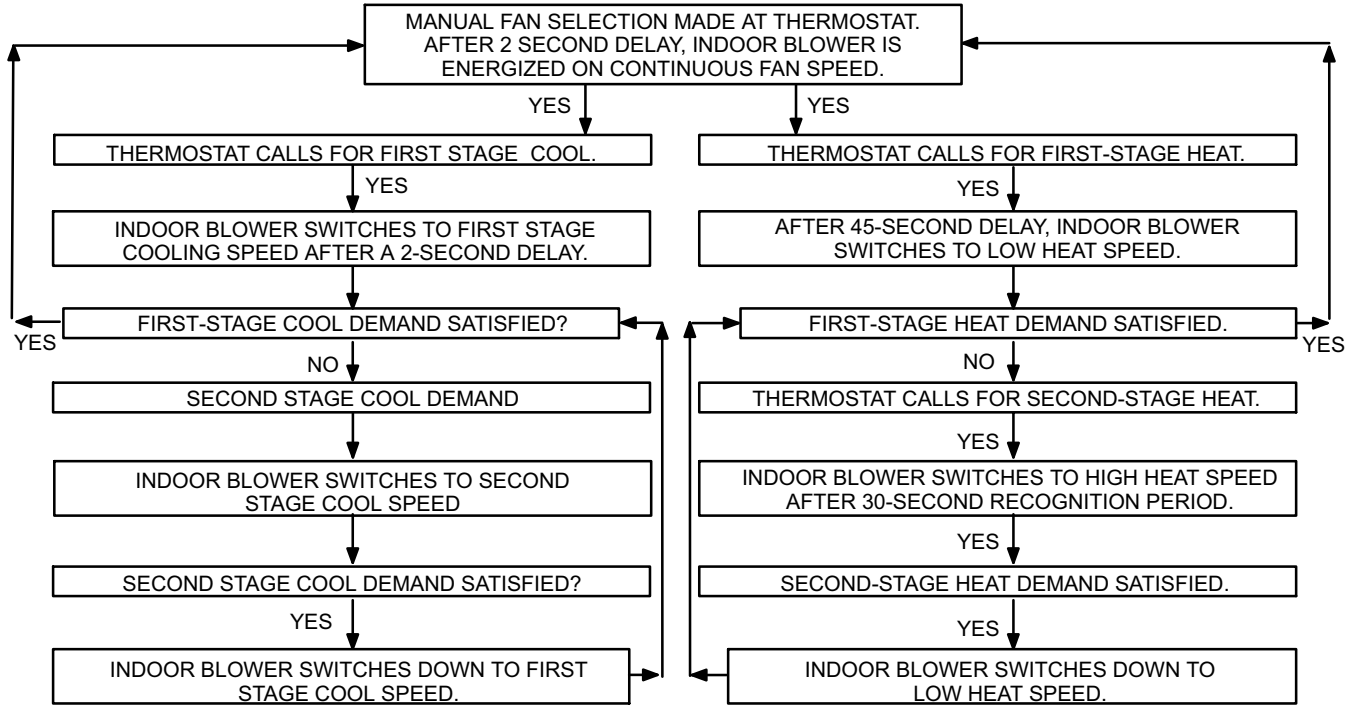

VIII- Field Wiring & Jumper Settings

A-SureLight Board 18M34

Thermostat	Jumper Settings (See figure 4)		Wiring Connections
	E20	Term. Strip Y1 to Y2	
1 Heat / 1 Cool <i>NOTE - Use dip switch 3 to set second-stage heat ON delay. ON-10 minutes. OFF-15 minutes.</i>	SINGLE	Leave Installed	
1 Heat / 2 Cool <i>NOTE - Use dip switch 3 to set second-stage heat ON delay. ON-10 minutes. OFF-15 minutes.</i>	SINGLE	Clip	
2 Heat / 2 Cool	TWO	Clip	
2 Heat / 1 Cool	TWO	Leave Installed	

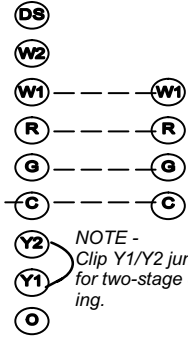
Thermostat	Jumper Settings (See figure 4)		Wiring Connections
	E20	Term. Strip Y1 to Y2	
FM21 Heat Pump / 1 Cool	SINGLE	Leave Installed	<div style="display: flex; justify-content: space-between;"> <div style="width: 45%;"> <p>*Disconnect existing furnace transformer and replace with 75VA, 24V transformer if defrost option to be used.</p> <p>75VA, 24V TRANSFORMER* </p> <p>NOTE - Wiring connections to outdoor unit and thermostat made at FM21 control board per FM21 instructions.</p> </div> <div style="width: 50%;"> <p style="text-align: center;">CONTROL TERM. STRIP</p> <p style="text-align: right;">FM21</p> <p>  </p> <p>NOTE - Clip Y1/Y2 jumper for two-stage cooling.</p> </div> </div>

B-SureLight Board 100869

TABLE 20
Field Wiring Applications (Continued)

Thermostat	Jumper Settings (See figure 5)			Wiring Connections
	DIP Switch 1	W915 Two-Stage Cooling	W951 Heat Pumps	
1Heat / 1 Cool <i>NOTE - Use DIP switch 2 to set second-stage heat ON delay.</i> <i>OFF-10 minutes.</i> <i>ON-15 minutes.</i>	ON	Intact	Intact	
1 Heat / 2 Cool <i>NOTE - Use DIP switch 2 to set second-stage heat ON delay.</i> <i>OFF-10 minutes.</i> <i>ON-15 minutes.</i>	ON	Cut	Intact	

TABLE 21
Field Wiring Applications (Continued)

Thermostat	Jumper Settings (See figure 5)			Wiring Connections																											
	DIP Switch 1	W915 Two-Stage Cooling	W951 Heat Pumps																												
2 Heat / 2 Cool	OFF	Cut	Intact	<table border="0"> <tr> <td>S1 T'STAT</td> <td>CONTROL TERM. STRIP</td> <td>OUTDOOR UNIT</td> </tr> <tr> <td>W2</td> <td>W2</td> <td></td> </tr> <tr> <td>W1</td> <td>W1</td> <td></td> </tr> <tr> <td>R</td> <td>R</td> <td></td> </tr> <tr> <td>G</td> <td>G</td> <td></td> </tr> <tr> <td>C</td> <td>C</td> <td>C</td> </tr> <tr> <td>Y2</td> <td>Y2</td> <td>Y2</td> </tr> <tr> <td>Y1</td> <td>Y1</td> <td>Y1</td> </tr> <tr> <td></td> <td>O</td> <td></td> </tr> </table>	S1 T'STAT	CONTROL TERM. STRIP	OUTDOOR UNIT	W2	W2		W1	W1		R	R		G	G		C	C	C	Y2	Y2	Y2	Y1	Y1	Y1		O	
S1 T'STAT	CONTROL TERM. STRIP	OUTDOOR UNIT																													
W2	W2																														
W1	W1																														
R	R																														
G	G																														
C	C	C																													
Y2	Y2	Y2																													
Y1	Y1	Y1																													
	O																														
2 Heat / 1 Cool	OFF	Intact	Intact	<table border="0"> <tr> <td>S1 T'STAT</td> <td>CONTROL TERM. STRIP</td> <td>OUTDOOR UNIT</td> </tr> <tr> <td>W2</td> <td>W2</td> <td></td> </tr> <tr> <td>W1</td> <td>W1</td> <td></td> </tr> <tr> <td>R</td> <td>R</td> <td></td> </tr> <tr> <td>G</td> <td>G</td> <td></td> </tr> <tr> <td>C</td> <td>C</td> <td>C</td> </tr> <tr> <td></td> <td>Y2</td> <td></td> </tr> <tr> <td>Y</td> <td>Y1</td> <td>Y1</td> </tr> <tr> <td></td> <td>O</td> <td></td> </tr> </table>	S1 T'STAT	CONTROL TERM. STRIP	OUTDOOR UNIT	W2	W2		W1	W1		R	R		G	G		C	C	C		Y2		Y	Y1	Y1		O	
S1 T'STAT	CONTROL TERM. STRIP	OUTDOOR UNIT																													
W2	W2																														
W1	W1																														
R	R																														
G	G																														
C	C	C																													
	Y2																														
Y	Y1	Y1																													
	O																														

IX- Integrated Control Board Troubleshooting Guide

A-SureLight Board 18M34

UPON INITIAL POWER UP, REMOVE ALL THERMOSTAT DEMANDS TO THE UNIT

PROBLEM: 1 UNIT FAILS TO OPERATE IN THE COOLING, HEATING, OR CONTINUOUS FAN MODE		
Condition	Possible Cause	Corrective Action / Comments
<p>1.1</p> <p>- Both diagnostic lights fail to light up.</p> <p>LED#1-Off LED#2-Off</p>	<p>1.1.1</p> <p>Main voltage 120V not supplied to unit.</p>	<p>ACTION 1 - Check 120V main voltage. Determine cause of main power failure.</p>
	<p>1.1.2</p> <p>Miswiring of furnace or improper connections.</p>	<p>ACTION 1 - Check for correct wiring of 120V to power make up box and transformer. ACTION 2 - Check 24V wiring to control board.</p>
	<p>1.1.3</p> <p>Circuit breaker tripped or fails to close.</p>	<p>ACTION 1 - Replace circuit breaker if it is reset but does not have continuity. ACTION 2 - If circuit breaker still trips, check for short.</p>
	<p>1.1.4</p> <p>Door interlock switch failure.</p>	<p>ACTION 1 - Check that door switch is activated when door is closed. ACTION 2 - Check wire connections to switch, replace loose connectors. ACTION 3 - Check continuity of switch in closed position. Replace if defective.</p>
	<p>1.1.5</p> <p>Transformer Failure.</p>	<p>ACTION 1 - Check that transformer output is 24V. Replace if defective.</p>
	<p>1.1.6</p> <p>Failed control board.</p>	<p>ACTION 1 - If all the above items have been checked, replace board.</p>
<p>1.2</p> <p>- Diagnostic lights flash the reverse polarity code.</p> <p>LED#1-Fast Flash, LED#2-Slow Flash.</p>	<p>1.2.1</p> <p>120V main power polarity reversed.</p>	<p>ACTION 1 - Check the 120V has line and neutral correctly input into control. ACTION 2 - Reverse the line and neutral at the 120V field connection.</p>
<p>1.3</p> <p>- Diagnostic lights flash the improper main ground.</p> <p>LED#1-Alternating Fast Flash LED#2-Alternating Fast Flash</p>	<p>1.3.1</p> <p>Improper ground to the unit.</p>	<p>ACTION 1 - Check that the unit is properly ground. ACTION 2 - Install a proper main ground to the unit</p>
	<p>1.3.2</p> <p>Open ignitor circuit.</p>	<p>ACTION 1 - Check for correct wiring and loose connections in the ignitor circuit. Check multi-plug connections for correct installation.</p>
	<p>1.3.3</p> <p>Broken or failed ignitor.</p>	<p>ACTION 1 - Unplug ignitor and read resistance across ignitor. If resistance does not read between 10.9 and 19.7 ohms, replace the ignitor.</p>
	<p>1.3.4</p> <p>Line voltage is below 75V.</p>	<p>ACTION 1 - Check that the line voltage is above 75V. Determine cause of voltage drop and supply correct voltage to the control.</p>

PROBLEM 2: UNIT FAILS TO FIRE IN THE HEATING MODE, COMBUSTION AIR INDUCER DOES NOT ENERGIZE

Condition	Possible Cause	Corrective Action / Comments
<p align="center">2.1</p> <ul style="list-style-type: none"> - Unit operates with a cooling or continuous fan demand. - Combustion air inducer will not start with a Heating demand. - Diagnostic lights flash the limit failure mode. <p>LED#1-Slow Flash, LED#2-On</p>	<p align="center">2.1.1</p> <p>Primary Limit or secondary limit (if equipped) or rollout switch open.</p>	<p>ACTION 1 - Check continuity across switch(es). Switches reset automatically upon cool down. Rollout switch must be reset manually.</p> <p>ACTION 2 - Check for restrictions on blower inlet air (including filter) and outlet air. Determine cause for limit activation before placing unit back in operation.</p>
	<p align="center">2.1.2</p> <p>Miswiring of furnace or improper connections at limit switch(es).</p>	<p>ACTION 1 - Check for correct wiring and loose connections. Correct wiring and/or replace any loose connections.</p>
<p align="center">2.2</p> <ul style="list-style-type: none"> - Unit operates with a cooling and continuous fan demand. - Combustion air inducer will not start with a Heating demand. - Diagnostic lights flash the pressure switch failure code. <p>LED#1-Off, LED#2-Slow Flash</p>	<p align="center">2.2.1</p> <p>Miswiring of furnace or improper connections to combustion air inducer.</p>	<p>ACTION 1 - Check for correct wiring and loose connections. Correct wiring and/or replace any loose connections.</p>
	<p align="center">2.2.2</p> <p>Prove switch stuck closed.</p>	<p>ACTION 1 - Check that the prove switch is open without the combustion air inducer operating. Replace if defective.</p>
<p align="center">2.3</p> <ul style="list-style-type: none"> - Unit operates with a cooling and continuous fan demand. - Combustion air inducer will not start with a Heating demand. - Diagnostic lights flash the pressure switch failure code 2.5 minutes after heating demand. <p>LED#1-Off, LED#2-Slow Flash</p>	<p align="center">2.3.1</p> <p>Miswiring of furnace or improper connections to combustion air inducer.</p>	<p>ACTION 1 - Check for correct wiring and loose connections. Correct wiring and/or replace any loose connections.</p>
	<p align="center">2.3.2</p> <p>Combustion air inducer failure.</p>	<p>ACTION 1 - If there is 120V to combustion air inducer and it does not operate, replace combustion air inducer.</p>

PROBLEM 3: UNIT FAILS TO FIRE IN THE HEATING MODE, COMBUSTION AIR BLOWER ENERGIZES, IGNITOR IS NOT ENERGIZED.

Condition	Possible Cause	Corrective Action/Comments
<p align="center">3.1</p> <ul style="list-style-type: none"> - Unit operates with a cooling and continuous fan demand. - Combustion air inducer energizes with a heating demand. - Diagnostic lights flash the pressure switch failure code 2.5 minutes after heating demand. <p>LED#1-Off LED#2-Slow Flash</p>	<p align="center">3.1.1</p> <p>Prove switch does not close due to incorrect routing of the prove switch line.</p>	<p>ACTION 1 - Check that the prove switch line is correctly routed. Correctly route pressure switch line.</p>
	<p align="center">3.1.2</p> <p>Prove switch does not close due to obstructions in the pressure switch line.</p>	<p>ACTION 1 - Remove any obstructions from the the prove switch line and/or taps.</p>
	<p align="center">3.1.3</p> <p>Prove switch line damaged</p>	<p>ACTION 1 - Check prove switch line for leaks. Replace broken line if required.</p>
	<p align="center">3.1.4</p> <p>Condensate in prove switch line.</p>	<p>ACTION 1 - Check prove switch line for condensate. Remove condensate from line.</p>
	<p align="center">3.1.5</p> <p>Prove switch does not close due to a low differential pressure across the prove switch.</p>	<p>ACTION 1 - Check the differential pressure across the prove switch. This pressure should exceed the set point listed on the switch. ACTION 2 - Check for restricted inlet vent. Remove all blockage. ACTION 3 - Check for proper vent sizing and run length. See installation instructions.</p>
	<p align="center">3.1.6</p> <p>Wrong prove switch installed in the unit, or pressure switch is out of calibration.</p>	<p>ACTION 1 - Check that the proper prove switch is installed in the unit. Replace prove switch if necessary.</p>
	<p align="center">3.1.7</p> <p>Miswiring of furnace or improper-connections at prove switch.</p>	<p>ACTION 1 - Check for correct wiring and loose connections. Correct wiring and/or replace any loose connections.</p>
	<p align="center">3.1.8</p> <p>Prove switch failure.</p>	<p>ACTION 1 - If all the above modes of failure have been checked, the prove switch may have failed. Replace pressure switch and determine if unit will operate.</p>

PROBLEM 4: UNIT FAILS TO FIRE IN THE HEATING MODE, COMBUSTION AIR BLOWER ENERGIZES, IGNITOR IS ENERGIZED.		
Condition	Possible Cause	Corrective Action/Comments
<p>4.1</p> <ul style="list-style-type: none"> - Unit operates with a cooling and continuous fan demand. - Combustion air inducer energizes with Heating demand. - Ignitor is energized but unit fails to light. <p>LED#1-Alternating Slow Flash LED#2-Alternating Slow Flash</p>	<p>4.1.1</p> <p>Check that gas is being supplied to the unit.</p>	<p>ACTION 1 - Check line pressure at the gas valve. Pressure should not exceed 13" WC for both natural and propane. Line pressure should read a minimum 4.5" WC for natural and 11.0"WC for propane.</p>
	<p>4.1.2</p> <p>Miswiring of gas valve or loose connections at multi-pin control amp plugs or valve.</p>	<p>ACTION 1 - Check for correct wiring and loose connections. Correct wiring and/or replace any loose connections.</p>
	<p>4.1.3</p> <p>Defective gas valve or ignition control.</p>	<p>ACTION 1 - Check that 24V is supplied to the gas valve approximately 35 seconds after heat demand is initiated. ACTION 2 - Replace the valve if 24V is supplied but valve does not open. ACTION 3 - Replace the control board if 24V is not supplied to valve.</p>
PROBLEM 5: BURNERS LIGHT WITH A HEATING DEMAND BUT UNIT SHUTS DOWN PREMATURELY		
Condition	Possible Cause	Corrective Action/Comments
<p>5.1</p> <ul style="list-style-type: none"> - Burners fire with a heating demand. - Burners light but unit shuts off prior to satisfying T-stat demand. - Diagnostic lights flash the pressure switch code. <p>LED#1-Off LED#2-Slow Flash</p>	<p>5.1.1</p> <p>Low pressure differential at the prove switch.</p>	<p>ACTION 1 - Check for restricted exhaust vent. Remove all blockage. ACTION 2: Check for proper vent sizing. See installation instructions.</p>
	<p>5.2</p> <ul style="list-style-type: none"> - Combustion air inducer energizes with a heating demand. - Burners light but fail to stay lit. - After 5 tries the control diagnostics flash the watchguard burners failed to ignite code. <p>LED#1-Alternating Slow Flash LED#2-Alternating Slow Flash</p>	<p>5.2.1</p> <p>Sensor or sense wire is improperly installed.</p>
	<p>5.2.2</p> <p>Sensor or sense wire is broken.</p>	<p>ACTION 1 - Check for a broken sensor. ACTION 2 - Test continuity across the sense wire. If wire or sensor are damaged replace the component.</p>
	<p>5.2.3</p> <p>Sensor or sensor wire is grounded to the unit.</p>	<p>ACTION 1 - Check for resistance between the sensor rod and the unit ground. ACTION 2 - Check for resistance between the sensor wire and the unit ground. ACTION 3 - Correct any shorts found in circuit.</p>
	<p>5.2.4</p> <p>Control does not sense flame.</p>	<p>ACTION 1 - Check the microamp signal from the burner flame. If the microamp signal is below normal microamps, check the sense rod for proper location or contamination. ACTION 2 - Replace, clean, or relocate flame sense rod. If rod is to be cleaned, use steel wool or replace sensor. DO NOT CLEAN ROD WITH SAND PAPER. SAND PAPER WILL CONTRIBUTE TO THE CONTAMINATION PROBLEM. NOTE: Do not attempt to bend sense rod. ACTION 3 - Check that there is proper ground to burner box. Repair as necessary.</p>

**PROBLEM 5: BURNERS LIGHT WITH HEATING DEMAND BUT UNIT SHUTS DOWN
PREMATURELY (CONT.)**

Condition	Possible Cause	Corrective Action/Comments
<p align="center">5.3</p> <ul style="list-style-type: none"> - Combustion air inducer energizes with a heating demand. - Burners light. - Roll-out switch trips during the heating demand. - Diagnostic lights flash limit / roll-out switch failure. <p>LED#1-Slow Flash LED#2-On</p>	<p align="center">5.3.1</p> <p align="center">Unit is firing above 100% of the nameplate input.</p>	<p>ACTION 1 - Check that the manifold pressure matches value listed on nameplate. See installation instructions for proper procedure.</p> <p>ACTION 2 - Verify that the installed orifice size match the size listed on the nameplate or installation instructions.</p> <p>ACTION 3 - Check the input rate to verify rate matches value listed on nameplate.</p>
	<p align="center">5.3.2</p> <p align="center">Gas orifices leak at the manifold connection.</p>	<p>ACTION 1 - Tighten orifice until leak is sealed. NOTE: Be careful not to strip orifice threads.</p> <p>ACTION 2 - Check for gas leakage at the threaded orifice connection. Use approved method for leak detection (see unit instructions).</p>
	<p align="center">5.3.3</p> <p align="center">Insufficient flow through the heat exchanger caused by a sooted or restricted heat exchanger.</p>	<p>ACTION 1 - Check for sooting deposits or other restrictions in the heat exchanger assembly. Clean assembly as outlined in instruction manual.</p> <p>ACTION 2 - Check for proper combustion. See IV-Heating System Service Checks section G-.</p>
	<p align="center">5.3.4</p> <p align="center">Burners are not properly located in the burner box.</p>	<p>ACTION 1 - Check that the burners are firing into the center of the heat exchanger openings. Correct the location of the burners if necessary.</p>
	<p align="center">5.3.5</p> <p align="center">Poor Venting</p>	<p>ACTION 1 -Check vent pipe and remove any obstructions</p> <p>ACTION 2 - Check for correct exhaust vent installation. See instructions</p>
	<p align="center">5.3.6</p> <p align="center">Improper burner cross-overs</p>	<p>ACTION 1 - Remove burner and inspect the cross-overs for burrs, or any restriction or if crossover is warped. Remove restriction or replace burners.</p>
<p align="center">5.4</p> <ul style="list-style-type: none"> - Combustion air inducer energizes with a heating demand. - Burners light roughly and the unit fails to stay lit. - Diagnostic lights flash watchguard flame failure. <p>LED#1-Alternating Slow Flash LED#2-Alternating Slow Flash</p>	<p align="center">5.4.1</p> <p align="center">Poor Venting</p>	<p>ACTION 1 -Check vent pipe and remove any obstructions</p> <p>ACTION 2 - Check for correct exhaust vent installation. See instructions</p>
	<p align="center">5.4.2</p> <p align="center">Improper burner cross-overs</p>	<p>ACTION 1 - Remove burner and inspect the cross-overs for burrs, or any restriction or if crossover is warped. Remove restriction or replace burners.</p>
	<p align="center">5.4.3</p> <p align="center">Burrs in gas orifices</p>	<p>ACTION 1 - Remove gas orifices and inspect. Remove any burrs that are present or replace orifice.</p>
	<p align="center">5.4.4</p> <p align="center">Prove Switch opens 5 times during a single demand</p>	<p>ACTION 1 - Inspect vent pipe installation and for any restriction. Remove restriction.</p> <p>ACTION 2 - Check prove switch reliability.</p>

PROBLEM 5: BURNERS LIGHT WITH HEATING DEMAND BUT UNIT SHUTS DOWN PREMATURELY (CONT.)

<p align="center">5.5</p> <ul style="list-style-type: none"> - Combustion air inducer energizes with a heating demand. - Burners light. - Diagnostic lights flash watch guard flame failure. - NOTE" Unit might go into 60 minute Watchguard mode depending on intermittent nature of sensor signal. <p>LED#1-Alternating Slow Flash LED#2-Alternating Slow Flash</p>	<p align="center">5.5.1</p> <p>Loose sensor wire connection causes intermittent loss of flame signal.</p>	<p>ACTION 1 - Check that the sensor is properly located.</p> <p>ACTION 2 - Check that the sense wire is properly attached to both the sensor and the control. Pay extra attention to the pin connectors.</p>
	<p align="center">5.5.2</p> <p>Poor ground to burner box</p>	<p>ACTION 1 - Check for proper ground and repair as necessary.</p>

PROBLEM 6: CONTROL SIGNALS LOW FLAME SENSE DURING HEATING MODE

Condition	Possible Cause	Corrective Action/Comments
<p align="center">6.0</p> <ul style="list-style-type: none"> - Unit operates correctly but the diagnostic lights flash low flame sense code. <p>LED#1-Slow Flash LED#2-Fast Flash</p>	<p align="center">6.1.1</p> <p>Sense rod is improperly located on the burner.</p>	<p>ACTION 1 - Check the sense rod for proper location on the burner. Properly locate the sense rod or replace if rod cannot be located correctly.</p>
	<p align="center">6.1.2</p> <p>Sense rod is contaminated.</p>	<p>ACTION 1 - Check sense rod for contamination or coated surface. Clean the sense rod with steel wool or replace sensor. DO NOT USE SAND PAPER TO CLEAN ROD. SAND PAPER WILL CONTRIBUTE TO THE CONTAMINATION PROBLEM.</p>

PROBLEM 7: INDOOR BLOWER FAILS TO OPERATE IN COOLING, HEATING, OR CONTINUOUS FAN MODE

Condition	Possible Cause	Corrective Action/Comments
<p align="center">7.0</p> <ul style="list-style-type: none"> - Indoor blower fails to operate in continuous fan, cooling, or heating mode. 	<p align="center">7.1.1</p> <p>Miswiring of furnace or improper connections at control or indoor blower motor.</p>	<p>ACTION 1 - Correct wiring and/or replace any loose connections. Check for correct wiring and loose connections.</p>
	<p align="center">7.1.2</p> <p>120V is not being supplied to the indoor air blower or blower motor failure.</p>	<p>ACTION 1 - Check for 120V at the various calls for indoor blower by energizing "Y", "G", and "W" individually on the low voltage terminal strip. Note that when "W" is energized, the blower is delayed 45 seconds. If there is 120V to each motor tap but the blower does not operate, replace the motor.</p>
	<p align="center">7.1.3</p> <p>Defective control board</p>	<p>ACTION 1 - If there is not 120V when "Y", "G", or "W" is energized, replace the control.</p>
	<p align="center">7.1.4</p> <p>Defective run capacitor</p>	<p>ACTION 1 - Replace capacitor</p>

B-SureLight Board 100869

UPON INITIAL POWER UP, REMOVE ALL THERMOSTAT DEMANDS TO THE UNIT

PROBLEM: 1 UNIT FAILS TO OPERATE IN THE COOLING, HEATING, OR CONTINUOUS FAN MODE		
Flash Code LED X + Y	Possible Cause	Corrective Action / Comments
<p>1.1</p> <p>- Diagnostic lights fail to light up.</p> <p>LED OFF</p>	<p>1.1.1</p> <p>Main voltage 120V not supplied to unit.</p>	<p>ACTION 1 - Check 120V main voltage. Determine cause of main power failure.</p>
	<p>1.1.2</p> <p>Miswiring of furnace or improper connections.</p>	<p>ACTION 1 - Check for correct wiring of 120V to power make up box and transformer. ACTION 2 - Check 24V wiring to control board.</p>
	<p>1.1.3</p> <p>Circuit breaker tripped or fails to close.</p>	<p>ACTION 1 - Replace circuit breaker if it is reset but does not have continuity. ACTION 2 - If circuit breaker still trips, check for short.</p>
	<p>1.1.4</p> <p>Door interlock switch failure.</p>	<p>ACTION 1 - Check that door switch is activated when door is closed. ACTION 2 - Check wire connections to switch, replace loose connectors. ACTION 3 - Check continuity of switch in closed position. Replace if defective.</p>
	<p>1.1.5</p> <p>Transformer Failure.</p>	<p>ACTION 1 - Check that transformer output is 24V. Replace if defective.</p>
	<p>1.1.6</p> <p>Failed control board.</p>	<p>ACTION 1 - If all the above items have been checked, replace board.</p>
<p>1.2</p> <p>Diagnostic light flashes the reverse polarity code.</p> <p>LED 5 + 4</p>	<p>1.2.1</p> <p>120V main power polarity reversed.</p>	<p>ACTION 1 - Check the 120V has line and neutral correctly input into control. ACTION 2 - Reverse the line and neutral at the 120V field connection.</p>
<p>1.3</p> <p>- Diagnostic light flash the improper main ground.</p> <p>LED 5 + 3</p>	<p>1.3.1</p> <p>Improper ground to the unit.</p>	<p>ACTION 1 - Check that the unit is properly ground. ACTION 2 - Install a proper main ground to the unit</p>
<p>1.4</p> <p>- Diagnostic light flashes ignitor circuit fault.</p> <p>LED 4 + 7</p>	<p>1.4.1</p> <p>Open ignitor circuit.</p>	<p>ACTION 1 - Check for correct wiring and loose connections in the ignitor circuit. Check multi-plug connections for correct installation.</p>
	<p>1.4.2</p> <p>Broken or failed ignitor.</p>	<p>ACTION 1 - Unplug ignitor and read resistance across ignitor. If resistance does not read between 25 and 47 ohms, replace the ignitor.</p>
<p>1.5</p> <p>- Diagnostic light flashes low line voltage</p> <p>LED 4 + 8</p>	<p>1.5.1</p> <p>Line voltage is below 90V.</p>	<p>ACTION 1 - Check that the line voltage is above 90V. Determine cause of voltage drop and supply correct voltage to the control.</p>

PROBLEM 2: UNIT FAILS TO FIRE IN THE HEATING MODE, COMBUSTION AIR BLOWER DOES NOT ENERGIZE

Flash Code LED X + Y	Possible Cause	Corrective Action / Comments
<p align="center">2.1</p> <p>Unit operates with a cooling or continuous fan demand. Combustion air inducer will not start with a Heating demand. Diagnostic lights flash the limit failure mode.</p> <p align="center">LED 3 + 1</p>	<p align="center">2.1.1</p> <p>Primary Limit or secondary limit (if equipped) open.</p>	<p>ACTION 1 - Check continuity across switch(es). Switches reset automatically upon cool down.</p> <p>ACTION 2 - Check for restrictions on blower inlet air (including filter) and outlet air. Determine cause for limit activation before placing unit back in operation.</p>
	<p align="center">2.1.2</p> <p>Miswiring of furnace or improper connections at limit switch(es).</p>	<p>ACTION 1 - Check for correct wiring and loose connections. Correct wiring and/or replace any loose connections.</p>
<p align="center">2.2</p> <p>Unit operates with a cooling and continuous fan demand. Combustion air inducer will not start with a Heating demand. Diagnostic lights flash the pressure switch failure code.</p> <p align="center">LED 2 +4</p>	<p align="center">2.2.1</p> <p>Miswiring of furnace or improper connections to combustion air inducer.</p>	<p>ACTION 1 - Check for correct wiring and loose connections. Correct wiring and/or replace any loose connections.</p>
	<p align="center">2.2.2</p> <p>Prove switch stuck closed.</p>	<p>ACTION 1 - Check that the prove switch is open without the combustion air inducer operating. Replace if defective.</p>
<p align="center">2.3</p> <p>Unit operates with a cooling or continuous fan demand. Combustion air inducer will not start with a Heating demand. Diagnostic lights flash the open rollout failure mode.</p> <p align="center">LED 5 + 1</p>	<p align="center">2.3.1</p> <p>Rollout Switch Open.</p>	<p>ACTION 1 - Check continuity across rollout switches. Rollout switches must be manually reset.</p> <p>ACTION 2 - Look for restrictions in vent pipe or combustion air inlet or heat exchanger. Determine cause before placing unit in operation.</p>

PROBLEM 3: UNIT FAILS TO FIRE IN THE HEATING MODE, COMBUSTION AIR INDUCER DOES NOT ENERGIZE

Condition	Possible Cause	Corrective Action/Comments
<p align="center">3.3</p> <p>Unit operates with a cooling and continuous fan demand. Combustion air inducer will not start with a Heating demand. Diagnostic lights flash the pressure switch failure code 2.5 minutes after heating demand.</p> <p align="center">LED 2 + 3</p>	<p align="center">3.3.1</p> <p>Miswiring of furnace or improper connections to combustion air inducer.</p>	<p>ACTION 1 - Check for correct wiring and loose connections. Correct wiring and/or replace any loose connections.</p>
	<p align="center">3.3.2</p> <p>Combustion air inducer failure.</p>	<p>ACTION 1 - If there is 120V to combustion air inducer and it does not operate, replace combustion air inducer.</p>

PROBLEM 4: UNIT FAILS TO FIRE IN THE HEATING MODE, COMBUSTION AIR INDUCER ENERGIZES, IGNITOR IS NOT ENERGIZED.

Flash Code LED X + Y	Possible Cause	Corrective Action/Comments
<p align="center">4.1</p> <ul style="list-style-type: none"> - Unit operates with a cooling and continuous fan demand. - Combustion air inducer energizes with a heating demand. - Diagnostic lights flash the pressure switch failure code 2.5 minutes after heating demand. <p align="center">LED 2 + 3</p>	<p align="center">4.1.1</p> <p>Prove switch does not close due to obstruction in vent pipe.</p>	<p>ACTION 1 - Check for restricted vent. Remove all blockage. ACTION 2: Check for proper vent sizing. See installation instructions.</p>
	<p align="center">4.1.2</p> <p>Prove switch does not close due to incorrect routing of the prove switch line.</p>	<p>ACTION 1 - Check that the prove switch line is correctly routed. Correctly route prove switch line.</p>
	<p align="center">4.1.3</p> <p>Prove switch does not close due to obstructions in the prove switch line.</p>	<p>ACTION 1 - Remove any obstructions from the the prove switch line and/or taps.</p>
	<p align="center">4.1.4</p> <p>Prove switch line damaged</p>	<p>ACTION 1 - Check prove switch line for leaks. Replace broken line if required.</p>
	<p align="center">4.1.5</p> <p>Condensate in prove switch line.</p>	<p>ACTION 1 - Check prove switch line for condensate. Remove condensate from line.</p>
	<p align="center">4.1.6</p> <p>Prove switch does not close due to a low differential pressure across the prove switch.</p>	<p>ACTION 1 - Check the differential pressure across the prove switch. This pressure should exceed the set point listed on the switch. ACTION 2 - Check for restricted inlet vent. Remove all blockage. ACTION 3 - Check for proper vent sizing and run length. See installation instructions.</p>
	<p align="center">4.1.7</p> <p>Wrong prove switch installed in the unit, or prove switch is out of calibration.</p>	<p>ACTION 1 - Check that the correct prove switch is installed in the unit. Replace prove switch if necessary.</p>
	<p align="center">4.1.8</p> <p>Miswiring of furnace or improper connections at prove switch.</p>	<p>ACTION 1 - Check for correct wiring and loose connections. Correct wiring and/or replace any loose connections.</p>
	<p align="center">4.1.9</p> <p>Prove switch failure.</p>	<p>ACTION 1 - If all the above modes of failure have been checked, the prove switch may have failed. Replace prove switch and determine if unit will operate.</p>

PROBLEM 5: UNIT FIRES ON LOW FIRE, FAILS TO GO TO HIGH FIRE OPERATION

Flash Code LED X + Y	Possible Cause	Corrective Action/Comments
<p align="center">5.1</p> <p>- Unit lights normally during low fire - Call for high fire inducer switches to high fire for 10 seconds then back to low fire. - Diagnostic lights flash the high pressure switch failure to close.</p> <p align="center">LED 2 + 5</p>	<p align="center">5.1.1</p> <p>Prove switch does not close due to obstruction in vent pipe.</p>	<p>ACTION 1 - Check for restricted vent. Remove all blockage. ACTION 2: Check for proper vent sizing. See installation instructions.</p>
	<p align="center">5.1.2</p> <p>Prove switch does not close due to incorrect routing of the prove switch line.</p>	<p>ACTION 1 - Check that the prove switch line is correctly routed. Correctly route prove switch line.</p>
	<p align="center">5.1.3</p> <p>Prove switch does not close due to obstructions in the prove switch line.</p>	<p>ACTION 1 - Remove any obstructions from the the prove switch line and/or taps.</p>
	<p align="center">5.1.4</p> <p>Prove switch line damaged</p>	<p>ACTION 1 - Check prove switch line for leaks. Replace broken line if required.</p>
	<p align="center">5.1.5</p> <p>Condensate in prove switch line.</p>	<p>ACTION 1 - Check prove switch line for condensate. Remove condensate from line.</p>
	<p align="center">5.1.6</p> <p>Prove switch does not close due to a low differential prove across the prove switch.</p>	<p>ACTION 1 - Check the differential pressure across the prove switch. This pressure should exceed the set point listed on the switch. ACTION 2 - Check for restricted inlet vent. Remove all blockage. ACTION 3 - Check for proper vent sizing and run length. See installation instructions.</p>
	<p align="center">5.1.7</p> <p>Wrong prove switch installed in the unit, or prove switch is out of calibration.</p>	<p>ACTION 1 - Check that the correct prove switch is installed in the unit. Replace prove switch if necessary.</p>
	<p align="center">5.1.8</p> <p>Miswiring of furnace or improper connections at prove switch.</p>	<p>ACTION 1 - Check for correct wiring and loose connections. Correct wiring and/or replace any loose connections.</p>
	<p align="center">5.1.9</p> <p>Prove switch failure.</p>	<p>ACTION 1 - If all the above modes of failure have been checked, the prove switch may have failed. Replace prove switch and determine if unit will operate.</p>

PROBLEM 6: UNIT FAILS TO FIRE IN THE HEATING MODE, COMBUSTION AIR BLOWER ENERGIZES, IGNITOR IS ENERGIZED.

Flash Code LED X + Y	Possible Cause	Corrective Action/Comments
6.1 Unit operates with a cooling and continuous fan demand. Combustion air inducer energizes with Heating demand. Ignitor is energized but unit fails to light.	6.1.1 Check that gas is being supplied to the unit.	ACTION 1 - Check line pressure at the gas valve. Pressure should not exceed 13" WC for both natural and propane. Line pressure should read a minimum 4.5" WC for natural and 8.0"WC for propane.
	6.1.2 Miswiring of gas valve or loose connections at multi-pin control amp plugs or valve.	ACTION 1 - Check for correct wiring and loose connections. Correct wiring and/or replace any loose connections.
LED 4 + 1	6.1.3 Defective gas valve or ignition control.	ACTION 1 - Check that 24V is supplied to the gas valve approximately 35 seconds after heat demand is initiated. ACTION 2 - Replace the valve if 24V is supplied but valve does not open. ACTION 3 - Replace the control board if 24V is not supplied to valve.

PROBLEM 7: BURNERS LIGHT WITH A HEATING DEMAND BUT UNIT SHUTS DOWN PREMATURELY

Flash Code LED X + Y	Possible Cause	Corrective Action/Comments
7.1 Burners fire with a heating demand. Burners light but unit shuts off prior to satisfying T-stat demand. Diagnostic lights flash the prove switch code.	7.1.1 Low pressure differential at the prove switch.	ACTION 1 - Check for restricted exhaust vent. Remove all blockage. ACTION 2: Check for proper vent sizing. See installation instructions.
LED 2 + 3		
7.2 Combustion air inducer energizes with a heating demand. Burners light but fail to stay lit. After 5 tries the control diagnostics flash the watchguard burners failed to ignite code.	7.2.1 Sensor or sense wire is improperly installed.	ACTION 1 - Check that sensor is properly located and that the sense wire is properly attached to both the sensor and the control.
	7.2.2 Sensor or sense wire is broken.	ACTION 1 - Check for a broken sensor. ACTION 2 - Test continuity across the sense wire. If wire or sensor are damaged replace the component.
LED 4 + 3	7.2.3 Sensor or sensor wire is grounded to the unit.	ACTION 1 - Check for resistance between the sensor rod and the unit ground. ACTION 2 - Check for resistance between the sensor wire and the unit ground. ACTION 3 - Correct any shorts found in circuit.
	7.2.4 Control does not sense flame.	ACTION 1 - Check the microamp signal from the burner flame. If the microamp signal is below normal microamps, check the sense rod for proper location or contamination. ACTION 2 - Replace, clean, or relocate flame sense rod. If rod is to be cleaned, use steel wool or replace sensor. DO NOT CLEAN ROD WITH SAND PAPER. SAND PAPER WILL CONTRIBUTE TO THE CONTAMINATION PROBLEM. NOTE: Do not attempt to bend sense rod. ACTION 3 - Check that there is proper ground to burner box. Repair as necessary.

**PROBLEM 7: BURNERS LIGHT WITH HEATING DEMAND BUT UNIT SHUTS DOWN
PREMATURELY (CONT.)**

Flash Code LED X + Y	Possible Cause	Corrective Action/Comments
<p align="center">7.3</p> <p align="center">Combustion air inducer energizes with a heating demand. Burners light. Roll-out switch trips during the heating demand. Diagnostic lights flash roll-out switch failure.</p> <p align="center">LED 5 + 1</p>	<p align="center">7.3.1</p> <p align="center">Unit is firing above 100% of the nameplate input.</p>	<p>ACTION 1 - Check that the manifold pressure matches value listed on nameplate. See installation instructions for proper procedure. ACTION 2 - Verify that the installed orifice size match the size listed on the nameplate or installation instructions. ACTION 3 - Check the input rate to verify rate matches value listed on nameplate.</p>
	<p align="center">7.3.2</p> <p align="center">Gas orifices leak at the manifold connection.</p>	<p>ACTION 1 - Tighten orifice until leak is sealed. NOTE: Be careful not to strip orifice threads. ACTION 2 - Check for gas leakage at the threaded orifice connection. Use approved method for leak detection (see unit instructions).</p>
	<p align="center">7.3.3</p> <p align="center">Insufficient flow through the heat exchanger caused by a sooted or restricted heat exchanger.</p>	<p>ACTION 1 - Check for sooting deposits or other restrictions in the heat exchanger assembly. Clean assembly as outlined in instruction manual. ACTION 2 - Check for proper combustion. See IV-Heating System Service Checks section G-.</p>
	<p align="center">7.3.4</p> <p align="center">Burners are not properly located in the burner box.</p>	<p>ACTION 1 - Check that the burners are firing into the center of the heat exchanger openings. Correct the location of the burners if necessary.</p>
	<p align="center">7.3.5</p> <p align="center">Poor Venting</p>	<p>ACTION 1 -Check vent pipe and remove any obstructions ACTION 2 - Check for correct exhaust vent installation. See instructions</p>
	<p align="center">7.3.6</p> <p align="center">Improper burner cross-overs</p>	<p>ACTION 1 - Remove burner and inspect the cross-overs for burrs, or any restriction or if crossover is warped. Remove restriction or replace burners.</p>
<p align="center">7.4</p> <p align="center">Combustion air inducer energizes with a heating demand. Burners light roughly and the unit fails to stay lit. Diagnostic lights flash watchguard flame failure.</p> <p align="center">LED 4 + 3</p>	<p align="center">7.4.1</p> <p align="center">Poor Venting</p>	<p>ACTION 1 -Check vent pipe and remove any obstructions ACTION 2 - Check for correct exhaust vent installation. See instructions</p>
	<p align="center">7.4.2</p> <p align="center">Improper burner cross-overs</p>	<p>ACTION 1 - Remove burner and inspect the cross-overs for burrs, or any restriction or if crossover is warped. Remove restriction or replace burners.</p>
	<p align="center">7.4.3</p> <p align="center">Burrs in gas orifices</p>	<p>ACTION 1 - Remove gas orifices and inspect. Remove any burrs that are present or replace orifice.</p>

PROBLEM 7: BURNERS LIGHT WITH HEATING DEMAND BUT UNIT SHUTS DOWN PREMATURELY (CONT.)

Flash Code LED X + Y	Possible Cause	Corrective Action/Comments
7.5 Combustion air inducer energizes with a heating demand. - Burners light. Diagnostic lights flash watch guard flame failure. NOTE" Unit might go into 60 minute Watchguard mode depending on intermittent nature of sensor signal.	7.5.1 Loose sensor wire connection causes intermittent loss of flame signal.	ACTION 1 - Check that the sensor is properly located. ACTION 2 - Check that the sense wire is properly attached to both the sensor and the control. Pay extra attention to the pin connectors.
LED 4 + 3	7.5.2 Poor ground to burner box	ACTION 1 - Check for proper ground and repair as necessary.

PROBLEM 8: CONTROL SIGNALS LOW FLAME SENSE DURING HEATING MODE

Condition	Possible Cause	Corrective Action/Comments
8.0 Unit operates correctly but the diagnostic lights flash low flame sense code.	8.1.1 Sense rod is improperly located on the burner.	ACTION 1 - Check the sense rod for proper location on the burner. Properly locate the sense rod or replace if rod cannot be located correctly.
LED 1 + 2	8.1.2 Sense rod is contaminated.	ACTION 1 - Check sense rod for contamination or coated surface. Clean the sense rod with steel wool or replace sensor. DO NOT USE SAND PAPER TO CLEAN ROD. SAND PAPER WILL CONTRIBUTE TO THE CONTAMINATION PROBLEM.

PROBLEM 9: INDOOR BLOWER FAILS TO OPERATE IN COOLING, HEATING, OR CONTINUOUS FAN MODE

Condition	Possible Cause	Corrective Action/Comments
9.0 - Indoor blower fails to operate in continuous fan, cooling, or heating mode.	9.1.1 Miswiring of furnace or improper connections at control or indoor blower motor.	ACTION 1 - Correct wiring and/or replace any loose connections. Check for correct wiring and loose connections.
	9.1.2 120V is not being supplied to the indoor air blower or blower motor failure.	ACTION 1 - PSC MOTORS Check for 120V at the various calls for indoor blower by energizing "Y", "G", and "W" individually on the low voltage terminal strip. Note that when "W" is energized, the blower is delayed 45 seconds. If there is 120V to each motor tap but the blower does not operate, replace the motor. ACTION 1 - VARIABLE SPEED MOTORS for operation of the VSM see NO TAG
	9.1.3 Defective control board	ACTION 1 - PSC MOTORS If there is not 120V when "Y", "G", or "W" is energized, replace the control.