

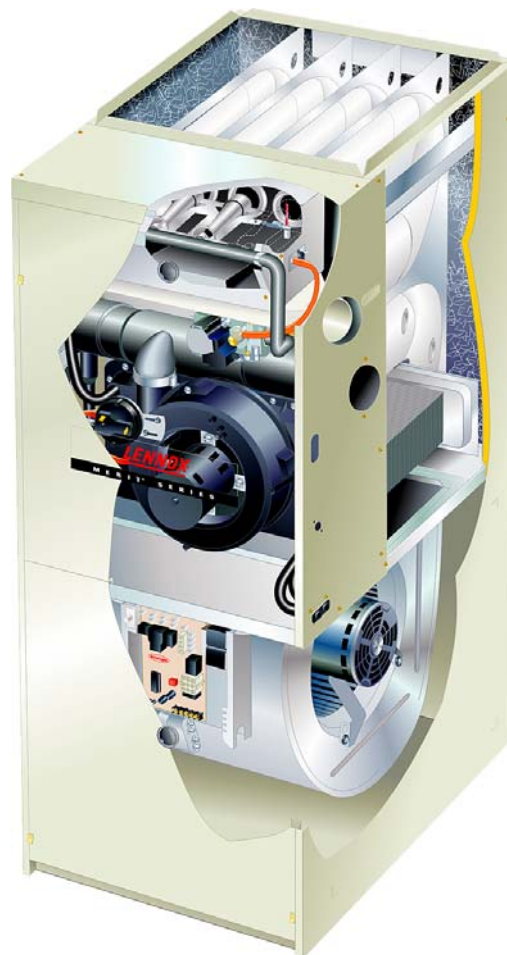
**G43UF SERIES UNITS**

G43UF series units are high-efficiency gas furnaces manufactured with Lennox DuralokPlus™ aluminized steel clamshell-type heat exchangers, with a stainless steel condensing coil. G43UF units are available in heating input capacities of 44,000 to 132,000 Btuh (13 to 38.6 kW) and cooling applications from 2 through 5 tons (7.0 through 17.6 kW). Refer to Engineering Handbook for proper sizing.

Units are factory equipped for use with natural gas. A kit is available for conversion to LPG operation. All G43UF units are equipped with a hot surface ignition system. The gas valve is redundant to assure safety shut-off as required by C.S.A.

The heat exchanger, burners and manifold assembly can be removed for inspection and service. The maintenance section gives a detailed description on how this is done.

Information contained in this manual is intended for use by qualified service technicians only. All specifications are subject to change. Procedures outlined in this manual are presented as a recommendation only and do not supersede or replace local or state codes.



**⚠ WARNING**



**Electric shock hazard. Can cause injury or death. Before attempting to perform any service or maintenance, turn the electrical power to unit OFF at disconnect switch(es). Unit may have multiple power supplies.**

**Table of Contents**

General .....	1
Specifications .....	2
Blower Performance Data .....	4
I-Unit Components .....	9
II Placement and Installation .....	18
III-Start-Up .....	31
IV-Heating System Service Checks .....	32
V-Typical Operating Conditions .....	35
High Altitude .....	35
VI-Maintenance .....	37
VII-Wiring and Sequence of Operation .....	39
VIII-Troubleshooting .....	49

**⚠ IMPORTANT**

**Improper installation, adjustment, alteration, service or maintenance can cause property damage, personal injury or loss of life. Installation and service must be performed by a qualified installer, service agency or the gas supplier.**

**⚠ WARNING**

**Sharp edges. Be careful when servicing unit to avoid sharp edges which may result in personal injury.**

SPECIFICATIONS						
Gas Heating Performance	Model No.	G43UF -24B-045	G43UF -24B-070	G43UF -36B-070	G43UF -36C-090	G43UF -36C-090H Canada Only
	Input - Btuh (kW)	44,000 (12.9)	66,000 (19.3)	66,000 (19.3)	88,000 (25.8)	88,000 (25.8)
	Output - Btuh (kW)	41,000 (12.0)	60,700 (17.8)	62,000 (18.2)	82,000 (24.0)	81,000 (23.7)
	<sup>1</sup> AFUE	92.1%	90.0%	92.1%	92.1%	90.0%
	California Seasonal Efficiency	82.7%	84.2%	85.1%	85.2%	84.2%
	High static (CSA) - in. w.g. (Pa)	.50 (124)	.50 (124)	.50 (124)	.50 (124)	.50 (124)
	Temperature rise range - °F (°C)	30 - 60 (18 - 36)	50 - 80 (28 - 44)	40 - 70 (22 - 39)	40 - 70 (22 - 39)	50 - 80 (28 - 44)
	<b>Connections in.</b>	<sup>2</sup> Intake Pipe (PVC)	2	2	2	2
	<sup>2</sup> Exhaust Pipe (PVC)	2	2	2	2	2
	Condensate Drain Trap (PVC pipe) - i.d.	1/2	1/2	1/2	1/2	1/2
	with field supplied (PVC coupling) - o.d.	3/4	3/4	3/4	3/4	3/4
	hose with hose clamp - i.d. x o.d.	1-1/4 x 1	1-1/4 x 1	1-1/4 x 1	1-1/4 x 1	1-1/4 x 1
	Gas pipe size IPS	1/2	1/2	1/2	1/2	1/2
<b>Indoor Blower</b>	Wheel nominal diameter x width - in. (mm)	10 x 7 (254 x 178)	10 x 7 (254 x 178)	10 x 8 (254 x 203)	10 x 8 (254 x 203)	10 x 8 (254 x 203)
	Motor output - hp (W)	1/5 (149)	1/5 (149)	1/3 (249)	1/3 (249)	1/3 (249)
	Tons (kW) of add-on cooling	1.5 - 2 (5.3 - 7.0)	1.5 - 2 (5.3 - 7.0)	2 - 3 (8.8 - 10.5)	2 - 3 (7.0 - 10.5)	2 - 3 (7.0 - 10.5)
<b>Shipping Data</b>	lbs. (kg) - 1 package	132 (60)	141 (64)	146 (66)	162 (74)	162 (74)
<b>Electrical characteristics</b>		120 volts - 60 hertz - 1 phase (less than 12 amps)				

SPECIFICATIONS						
Gas Heating Performance	Model No.	G43UF -48C-090	G43UF -48C-110	G43UF -48C-110H Canada Only	G43UF -60C-110	G43UF -60D-135
	Input - Btuh (kW)	88,000 (25.8)	110,000 (32.2)	110,000 (32.2)	110,000 (32.2)	132,000 (38.7)
	Output - Btuh (kW)	82,000 (24.0)	103,000 (30.2)	101,000 (29.6)	103,000 (30.2)	123,000 (36.0)
	<sup>1</sup> AFUE	92.1%	92.1%	90.0%	92.1%	92.1%
	California Seasonal Efficiency	85.5%	86.2%	84.7%	85.6%	86.0%
	High static (CSA) - in. w.g. (Pa)	.50 (124)	.50 (124)	.50 (124)	.50 (124)	.50 (124)
	Temperature rise range - °F (°C)	40 - 70 (22 - 39)	45 - 75 (27 - 45)	50 - 80 (28 - 44)	40 - 70 (22 - 39)	45 - 75 (27 - 45)
	<b>Connections in.</b>	<sup>2</sup> Intake Pipe (PVC)	2	2	2	2
	<sup>2</sup> Exhaust Pipe (PVC)	2	2	2	2	3
	Condensate Drain Trap (PVC pipe) - i.d.	1/2	1/2	1/2	1/2	1/2
	with field supplied (PVC coupling) - o.d.	3/4	3/4	3/4	3/4	3/4
	hose with hose clamp - i.d. x o.d.	1-1/4 x 1	1-1/4 x 1	1-1/4 x 1	1-1/4 x 1	1-1/4 x 1
	Gas pipe size IPS	1/2	1/2	1/2	1/2	1/2
<b>Indoor Blower</b>	Wheel nominal diameter x width - in. (mm)	10 x 10 (254 x 254)	10 x 10 (254 x 254)	10 x 10 (254 x 254)	11-1/2 x 10 (292 x 229)	11-1/2 x 10 (292 x 229)
	Motor output - hp (W)	1/2 (373)	1/2 (373)	1/2 (373)	1 (746)	1 (746)
	Tons (kW) of add-on cooling	3 - 4 (10.5 - 14)	3 - 4 (10.5 - 14)	3 - 4 (10.5 - 14)	4 - 5 (14 - 17.5)	4 - 5 (14 - 17.5)
<b>Shipping Data</b>	lbs. (kg) - 1 package	168 (76)	178 (81)	178 (81)	186 (84)	203 (92)
<b>Electrical characteristics</b>		120 volts - 60 hertz - 1 phase (less than 12 amps)				

NOTE - Filters and provisions for mounting are not furnished and must be field provided.

<sup>1</sup>Annual Fuel Utilization Efficiency based on DOE test procedures and according to FTC labeling regulations. Isolated combustion system rating for non-weatherized furnaces.

<sup>2</sup> Determine from venting tables proper exhaust pipe size and termination kit required.

**OPTIONAL ACCESSORIES - MUST BE ORDERED EXTRA**

			"B" Width Models	"C" Width Models	"D" Width Models
<b>FILTER KITS</b>					
<b><sup>1</sup> Air Filter and Rack Kit</b>	Side Return	Single	<b>44J22</b>	<b>44J22</b>	<b>44J22</b>
		Ten Pack	<b>66K63</b>	<b>66K63</b>	<b>66K63</b>
	Size of filter - in. (mm)		16 x 25 x 1 (406 x 635 x 25)	16 x 25 x 1 (406 x 635 x 25)	16 x 25 x 1 (406 x 635 x 25)
<b>EZ Filter Base</b>	Catalog No. - Ship. Wt. - lbs. (kg)		<b>73P56 - 7 (3)</b>	<b>73P57 - 8 (4)</b>	<b>73P58 - 10 (5)</b>
	Size of field provided filter - in. (mm)		16 x 25 x 1 (406 x 635 x 25)	20 x 25 x 1 (508 x 635 x 25)	24 x 24 x 1 (610 x 610 x 25)

**CABINET ACCESSORIES**

<b>Return Air Base</b>	<b>76M88</b>	<b>74M74</b>	<b>74M75</b>
------------------------	--------------	--------------	--------------

**CONDENSATE DRAIN KITS**

<b>Condensate Drain Heat Cable</b>	6 ft. (1.8 m)	<b>26K68</b>	<b>26K68</b>	<b>26K68</b>
	24 ft. (7.3 m)	<b>26K69</b>	<b>26K69</b>	<b>26K69</b>
	50 ft. (15.2 m)	<b>26K70</b>	<b>26K70</b>	<b>26K70</b>
<b>Heat Cable Tape</b>	Fiberglass - 1/2 in. x 66 ft.	<b>39G04</b>	<b>39G04</b>	<b>39G04</b>
	Aluminum foil - 2 in. x 60 ft.	<b>39G03</b>	<b>39G03</b>	<b>39G03</b>
<b>Condensate Trap Alternate Location Kit - Up-Flow Only</b>		<b>76M20</b>	<b>76M20</b>	<b>76M20</b>

**CONTROLS**

<b>Twinning Kit</b>	<b>15L38</b>	<b>15L38</b>	<b>15L38</b>
---------------------	--------------	--------------	--------------

**TERMINATION KITS - See Installation Instructions for specific venting information.**

<b>Termination Kits Concentric Direct Vent Applications Only</b>	1-1/2 in. (38 mm)	<b>71M80</b>	---	---	
	2 in. (51 mm)	---	<b>69M29</b>	---	
	3 in. (76 mm)	---	<b>60L46</b>	<b>60L46</b>	
	<b>Wall - Close Couple</b>	2 in. (51 mm)	<b>22G44</b>	---	---
		3 in. (76 mm)	<b>44J40</b>	<b>44J40</b>	<b>44J40</b>
	<b>Close Couple WTK</b>	2 in. (51 mm)	<b>30G28</b>	---	---
3 in. (76 mm)		<b>81J20</b>	<b>81J20</b>	<b>81J20</b>	
<b><sup>2</sup> Termination Kits - Direct or Non-Direct Vent</b>	<b>Roof</b>	2 in. (51 mm)	<b>15F75</b>	<b>15F75</b>	
	<b>Wall - Wall Ring Kit</b>	2 in (51 mm)	<b>15F74</b>	<b><sup>3</sup> 15F74</b>	
<b>Roof Termination Flashing Kit - Direct or Non-Direct Vent - Contains two flashings.</b>		<b>44J41</b>	<b>44J41</b>	<b>44J41</b>	

<sup>1</sup> Cleanable polyurethane frame type filter.

<sup>2</sup> Kits contain enough parts for two, non-direct vent installations.

<sup>3</sup> Non-direct vent only.

**GAS HEAT ACCESSORIES**

Input	Model No.	<sup>1</sup> High Altitude Orifice Kit Natural Gas Only	High Altitude Pressure Switch Kit		LPG/Propane Kit	
			4501-7500 ft. (1372-2286 m)	7501-10,000 ft. (2286-3048 m)	0-7500 ft. (0-2286 m)	7501-10,000 ft. (2286-3048 m)
-045	G43UF	59M16	---	95M22	83M74	83M75
-045-1 to -6	G43UF	59M16	---	56M06	83M74	83M75
-070	G43UF	59M16	56M05	56M06	83M74	83M75
-070-1 to -6	G43UF	59M16	---	56M06	83M74	83M75
-090	G43UF	59M16	75M20	56M07	83M74	83M75
-110	G43UF	59M16	75M20	56M07	83M74	83M75
-135	G43UF	59M16	56M04	60M35	83M74	83M75

<sup>1</sup> Required for proper operation at altitudes from 7501 to 10,000 ft. (2286 to 3048 m).

## BLOWER/WATTS DATA

### G43UF-24B-045-1, -3 PERFORMANCE

External Static Pressure		Air Volume / Watts at Different Blower Speeds								
		High			Medium			Low		
		in. w.g.	Pa	cfm	L/s	Watts	cfm	L/s	Watts	cfm
0.00	0	975	460	380	870	410	340	720	340	285
0.10	25	935	440	365	855	400	335	710	335	280
0.20	50	910	430	360	830	390	325	680	320	270
0.30	75	870	410	345	795	375	310	655	310	260
0.40	100	825	390	330	760	360	300	630	295	255
0.50	125	760	360	315	715	335	285	610	290	250
0.60	150	725	340	310	675	320	280	580	275	235
0.70	175	680	320	295	630	300	265	545	260	230
0.80	200	620	290	285	575	270	255	495	235	220
0.90	225	555	260	270	520	245	245	425	200	205

### G43UF-24B-070-1, -3 PERFORMANCE

External Static Pressure		Air Volume / Watts at Different Blower Speeds								
		High			Medium			Low		
		in. w.g.	Pa	cfm	L/s	Watts	cfm	L/s	Watts	cfm
0.00	25	1020	480	380	905	430	345	740	350	280
0.10	25	985	465	370	890	420	330	730	345	270
0.20	50	945	445	355	860	405	325	705	330	265
0.30	75	905	430	345	830	390	315	690	325	260
0.40	100	860	405	330	790	370	300	660	310	250
0.50	125	810	380	320	750	355	290	630	300	240
0.60	150	740	350	305	710	335	280	590	280	230
0.70	175	700	330	295	650	305	265	550	260	220
0.80	200	635	300	280	590	280	255	495	235	210
0.90	225	555	260	265	530	250	235	425	200	195

NOTES - All air data is measured external to unit with 1 in. foam filter (not furnished - field provided).  
Air volume based on bottom air return air. Actual air volume may vary on side return air applications.

### G43UF-24B-045-4 PERFORMANCE (Less Filter)

External Static Pressure		Air Volume / Watts at Different Blower Speeds											
		High			Medium-High			Medium-Low			Low		
		in. w.g.	Pa	cfm	L/s	Watts	cfm	L/s	Watts	cfm	L/s	Watts	cfm
0.00	0	1125	530	425	900	425	360	745	350	295	690	325	265
0.10	25	1115	525	410	905	425	350	760	360	285	695	330	260
0.20	50	1090	515	395	895	420	335	755	355	280	685	325	255
0.30	75	1060	500	380	880	415	325	740	350	270	675	320	250
0.40	100	1020	480	365	860	405	315	720	340	260	665	315	240
0.50	125	970	460	345	835	395	300	700	330	255	640	300	230
0.60	150	920	435	335	795	375	290	665	315	240	600	285	220
0.70	175	860	405	315	730	345	270	620	295	230	565	265	215
0.80	200	760	360	295	665	315	250	560	265	215	510	240	200
0.90	225	675	320	275	585	275	230	495	235	200	500	190	175

### G43UF-24B-070-4 PERFORMANCE (Less Filter)

External Static Pressure		Air Volume / Watts at Different Blower Speeds											
		High			Medium-High			Medium-Low			Low		
		in. w.g.	Pa	cfm	L/s	Watts	cfm	L/s	Watts	cfm	L/s	Watts	cfm
0.00	0	1115	525	435	875	415	360	720	340	290	665	315	255
0.10	25	1115	525	425	865	410	350	725	340	285	670	315	255
0.20	50	1100	520	415	870	410	335	730	345	280	665	315	250
0.30	75	1080	510	400	870	410	330	725	340	270	655	310	240
0.40	100	1050	495	385	855	405	320	715	335	265	645	305	240
0.50	125	1010	475	365	835	395	310	695	330	255	625	295	230
0.60	150	980	460	355	810	380	295	675	320	250	600	285	225
0.70	175	930	440	340	770	365	285	640	300	235	565	265	215
0.80	200	855	405	320	720	340	270	585	275	220	520	245	200
0.90	225	770	365	295	650	305	250	525	245	205	465	220	190

NOTES - All air data is measured external to unit without filter (not furnished - field provided).  
Air volume based on bottom air return air. Actual air volume may vary on side return air applications.

## BLOWER/WATTS DATA

### G43UF-36B-070 PERFORMANCE (Less Filter)

External Static Pressure		Air Volume / Watts at Different Blower Speeds											
in. w.g.	Pa	High			Medium-High			Medium-Low			Low		
		cfm	L/s	Watts	cfm	L/s	Watts	cfm	L/s	Watts	cfm	L/s	Watts
0.00	0	1640	775	660	1415	665	575	1160	545	485	1005	475	410
0.10	25	1600	755	635	1395	660	550	1160	545	460	1000	470	385
0.20	50	1540	725	605	1370	650	525	1160	545	445	995	470	375
0.30	75	1495	705	580	1345	635	505	1145	540	425	990	465	365
0.40	100	1420	670	545	1275	605	480	1125	530	395	965	455	345
0.50	125	1360	640	525	1245	590	450	1080	510	375	945	445	325
0.60	150	1275	600	490	1165	550	410	1025	485	350	900	425	305
0.70	175	1170	555	465	1085	515	385	965	430	335	860	405	295
0.80	200	1080	510	440	1010	475	360	865	410	310	775	365	270
0.90	225	945	445	400	840	395	320	765	360	275	710	335	245

NOTES - All air data is measured external to unit without filter (not furnished - field provided).  
Air volume based on bottom air return air. Actual air volume may vary on side return air applications.

### G43UF-36C-090(H) PERFORMANCE (Less Filter)

External Static Pressure		Air Volume / Watts at Different Blower Speeds											
in. w.g.	Pa	High			Medium-High			Medium-Low			Low		
		cfm	L/s	Watts	cfm	L/s	Watts	cfm	L/s	Watts	cfm	L/s	Watts
0.00	0	1630	770	745	1360	640	635	1125	530	540	975	460	440
0.10	25	1620	765	715	1365	645	610	1160	545	515	1000	470	430
0.20	50	1590	750	680	1365	645	580	1160	545	495	990	465	405
0.30	75	1550	730	655	1355	640	565	1170	550	475	985	465	395
0.40	100	1520	715	630	1330	630	545	1160	545	460	980	460	380
0.50	125	1465	690	605	1300	615	515	1140	540	440	960	455	360
0.60	150	1415	670	570	1250	590	490	1095	515	420	940	445	350
0.70	175	1350	635	545	1215	575	470	1065	500	400	905	425	335
0.80	200	1260	595	510	1140	540	440	1005	475	375	850	400	310
0.90	225	1165	550	475	1035	485	395	900	425	335	730	345	285

NOTES - All air data is measured external to unit without filter (not furnished - field provided).  
Air volume based on bottom air return air. Actual air volume may vary on side return air applications.

### G43UF-48C-090 PERFORMANCE (Less Filter)

External Static Pressure		Air Volume / Watts at Different Blower Speeds											
in. w.g.	Pa	High			Medium-High			Medium-Low			Low		
		cfm	L/s	Watts	cfm	L/s	Watts	cfm	L/s	Watts	cfm	L/s	Watts
0.00	0	2180	1030	930	1835	865	790	1520	715	630	1280	605	510
0.10	25	2135	1005	885	1825	860	750	1510	710	610	1275	600	495
0.20	50	2085	985	840	1810	855	720	1505	710	580	1270	600	475
0.30	75	2030	955	800	1775	835	685	1500	705	565	1265	595	460
0.40	100	1940	915	760	1735	820	650	1480	700	535	1250	590	440
0.50	125	1865	880	725	1660	785	600	1430	675	505	1215	575	425
0.60	150	1740	820	670	1590	750	575	1380	650	475	1175	555	410
0.70	175	1645	775	640	1475	695	520	1290	610	450	1105	520	375
0.80	200	1540	725	600	1340	630	465	1175	555	405	1020	480	355
0.90	225	1335	630	540	1170	555	440	1070	505	375	950	450	330

NOTES - All air data is measured external to unit without filter (not furnished - field provided).  
Air volume based on bottom air return air. Actual air volume may vary on side return air applications.

## BLOWER/WATTS DATA

### G43UF-48C-110 PERFORMANCE (Less Filter)

External Static Pressure		Air Volume / Watts at Different Blower Speeds											
		High			Medium-High			Medium-Low			Low		
in. w.g.	Pa	cfm	L/s	Watts	cfm	L/s	Watts	cfm	L/s	Watts	cfm	L/s	Watts
0.00	0	2160	1020	880	1880	890	755	1490	705	602	1235	580	485
0.10	25	2100	990	850	1855	875	730	1480	700	585	1230	580	475
0.20	50	2035	960	805	1815	860	690	1475	695	560	1225	580	460
0.30	75	1965	925	750	1755	830	650	1475	695	545	1220	575	445
0.40	100	1885	890	725	1715	810	625	1465	690	510	1215	575	430
0.50	125	1780	840	680	1630	770	580	1420	670	490	1150	540	400
0.60	150	1690	800	660	1550	735	550	1360	640	460	1110	525	380
0.70	175	1575	745	620	1410	665	505	1210	570	405	1035	490	350
0.80	200	1375	650	550	1230	580	450	1125	530	380	970	460	325
0.90	225	1225	580	520	1120	530	415	1050	495	365	885	420	310

NOTES - All air data is measured external to unit without filter (not furnished - field provided).  
Air volume based on bottom air return air. Actual air volume may vary on side return air applications.

### G43UF-60C-110(H) PERFORMANCE (Less Filter) - Single Side Return Air - Air volumes in bold require field fabricated transition to accommodate 20 x 25 x 1 in. (508 x 635 x 25 mm) air filter in order to maintain proper air velocity.

External Static Pressure		Air Volume / Watts at Different Blower Speeds											
		High			Medium-High			Medium-Low			Low		
in. w.g.	Pa	cfm	L/s	Watts	cfm	L/s	Watts	cfm	L/s	Watts	cfm	L/s	Watts
0.00	0	<b>2625</b>	<b>1240</b>	<b>1350</b>	<b>2310</b>	<b>1090</b>	<b>1080</b>	<b>1885</b>	<b>890</b>	<b>885</b>	1515	715	700
0.10	25	<b>2570</b>	<b>1215</b>	<b>1330</b>	<b>2325</b>	<b>1095</b>	<b>1060</b>	<b>1910</b>	<b>900</b>	<b>865</b>	1575	745	700
0.20	50	<b>2410</b>	<b>1135</b>	<b>1305</b>	<b>2285</b>	<b>1080</b>	<b>1035</b>	<b>1930</b>	<b>910</b>	<b>845</b>	1620	765	690
0.30	75	<b>2425</b>	<b>1145</b>	<b>1265</b>	<b>2230</b>	<b>1055</b>	<b>990</b>	<b>1925</b>	<b>905</b>	<b>825</b>	1635	770	675
0.40	100	<b>2335</b>	<b>1100</b>	<b>1220</b>	<b>2175</b>	<b>1025</b>	<b>950</b>	<b>1910</b>	<b>900</b>	<b>810</b>	1640	775	660
0.50	125	<b>2270</b>	<b>1070</b>	<b>1195</b>	<b>2120</b>	<b>1000</b>	<b>935</b>	<b>1895</b>	<b>895</b>	<b>785</b>	1640	775	640
0.60	150	<b>2170</b>	<b>1025</b>	<b>1155</b>	<b>2045</b>	<b>965</b>	<b>885</b>	<b>1860</b>	<b>875</b>	<b>765</b>	1630	770	630
0.70	175	<b>2110</b>	<b>995</b>	<b>1130</b>	<b>1950</b>	<b>920</b>	<b>855</b>	1795	845	730	1590	750	610
0.80	200	<b>2035</b>	<b>960</b>	<b>1090</b>	<b>1885</b>	<b>890</b>	<b>820</b>	1745	825	705	1540	725	580
0.90	225	<b>1900</b>	<b>895</b>	<b>1055</b>	1760	830	780	1665	785	680	1470	695	565

NOTES - All air data is measured external to unit without filter (not furnished - field provided).

### G43UF-60C-110 PERFORMANCE (Less Filter) - Bottom Return Air, Side Return Air with Optional RAB Return Air Base, Return Air from Both Sides or Return Air from Bottom and One Side.

External Static Pressure		Air Volume / Watts at Different Blower Speeds											
		High			Medium-High			Medium-Low			Low		
in. w.g.	Pa	cfm	L/s	Watts	cfm	L/s	Watts	cfm	L/s	Watts	cfm	L/s	Watts
0.00	0	2720	1285	1385	2410	1135	1090	2055	970	935	1620	765	710
0.10	25	2665	1255	1355	2385	1125	1075	2025	955	885	1730	815	735
0.20	50	2585	1220	1315	2350	1110	1015	2030	955	865	1680	795	690
0.30	75	2505	1180	1275	2290	1080	990	2025	955	840	1695	800	675
0.40	100	2435	1150	1250	2235	1055	940	2030	960	830	1695	800	660
0.50	125	2350	1110	1205	2170	1025	930	1975	930	790	1735	820	665
0.60	150	2255	1065	1185	2100	990	895	1915	905	765	1720	810	650
0.70	175	2160	1020	1150	2005	945	840	1865	880	730	1680	795	635
0.80	200	2020	955	1090	1905	900	825	1810	855	710	1625	765	610
0.90	225	1910	900	1050	1820	860	795	1705	805	675	1540	725	590

NOTES - All air data is measured external to unit without filter (not furnished - field provided).

## BLOWER/WATTS DATA

**G43UF-60D-135 PERFORMANCE (Less Filter) - Single Side Return Air - Air volumes in bold require field fabricated transition to accommodate 20 x 25 x 1 in. (508 x 635 x 25 mm) air filter in order to maintain proper air velocity.**

External Static Pressure		Air Volume / Watts at Different Blower Speeds											
in. w.g.	Pa	High			Medium-High			Medium-Low			Low		
		cfm	L/s	Watts	cfm	L/s	Watts	cfm	L/s	Watts	cfm	L/s	Watts
0.00	0	<b>2665</b>	<b>1260</b>	<b>1440</b>	<b>2325</b>	<b>1095</b>	<b>1100</b>	<b>1865</b>	<b>880</b>	<b>890</b>	1410	665	690
0.10	25	<b>2615</b>	<b>1235</b>	<b>1405</b>	<b>2310</b>	<b>1090</b>	<b>1065</b>	<b>1915</b>	<b>905</b>	<b>865</b>	1465	690	685
0.20	50	<b>2530</b>	<b>1195</b>	<b>1370</b>	<b>2280</b>	<b>1075</b>	<b>1055</b>	<b>1925</b>	<b>910</b>	<b>850</b>	1570	740	675
0.30	75	<b>2470</b>	<b>1165</b>	<b>1330</b>	<b>2235</b>	<b>1055</b>	<b>1015</b>	<b>1920</b>	<b>905</b>	<b>825</b>	1590	750	670
0.40	100	<b>2380</b>	<b>1125</b>	<b>1290</b>	<b>2175</b>	<b>1025</b>	<b>985</b>	<b>1910</b>	<b>900</b>	<b>805</b>	1590	750	655
0.50	125	<b>2310</b>	<b>1090</b>	<b>1265</b>	<b>2120</b>	<b>1000</b>	<b>965</b>	<b>1890</b>	<b>890</b>	<b>790</b>	1595	755	645
0.60	150	<b>2200</b>	<b>1035</b>	<b>1230</b>	<b>2055</b>	<b>970</b>	<b>935</b>	<b>1835</b>	<b>865</b>	<b>765</b>	1580	745	630
0.70	175	<b>2120</b>	<b>1000</b>	<b>1190</b>	<b>1970</b>	<b>930</b>	<b>900</b>	1790	845	740	1545	730	605
0.80	200	<b>2025</b>	<b>955</b>	<b>1160</b>	<b>1890</b>	<b>890</b>	<b>875</b>	1720	810	710	1515	715	590
0.90	225	<b>1930</b>	<b>910</b>	<b>1110</b>	<b>1800</b>	<b>850</b>	<b>835</b>	1655	780	685	1440	680	570

NOTES - All air data is measured external to unit without filter (not furnished - field provided).

**G43UF-60D-135 PERFORMANCE (Less Filter) - Bottom Return Air, Side Return Air with Optional RAB Return Air Base, Return Air from Both Sides or Return Air from Bottom and One Side.**

External Static Pressure		Air Volume / Watts at Different Blower Speeds											
in. w.g.	Pa	High			Medium-High			Medium-Low			Low		
		cfm	L/s	Watts	cfm	L/s	Watts	cfm	L/s	Watts	cfm	L/s	Watts
0.00	0	2730	1290	1465	2425	1145	1125	2055	970	915	1560	735	680
0.10	25	2670	1260	1440	2400	1135	1100	2065	975	890	1590	750	675
0.20	50	2600	1225	1400	2365	1115	1070	2045	965	865	1620	765	665
0.30	75	2525	1190	1360	2315	1095	1045	2035	960	845	1615	760	655
0.40	100	2445	1155	1325	2260	1065	1015	2020	955	820	1615	760	645
0.50	125	2360	1115	1280	2195	1035	985	1960	925	790	1610	760	635
0.60	150	2290	1080	1255	2130	1005	965	1900	895	755	1600	755	615
0.70	175	2205	1040	1220	2035	960	910	1825	860	730	1570	740	600
0.80	200	2110	995	1195	1945	915	880	1765	830	710	1540	725	580
0.90	225	1970	930	1120	1835	865	830	1680	795	690	1540	725	545

NOTES - All air data is measured external to unit without filter (not furnished - field provided).

# G43UF PARTS IDENTIFICATION

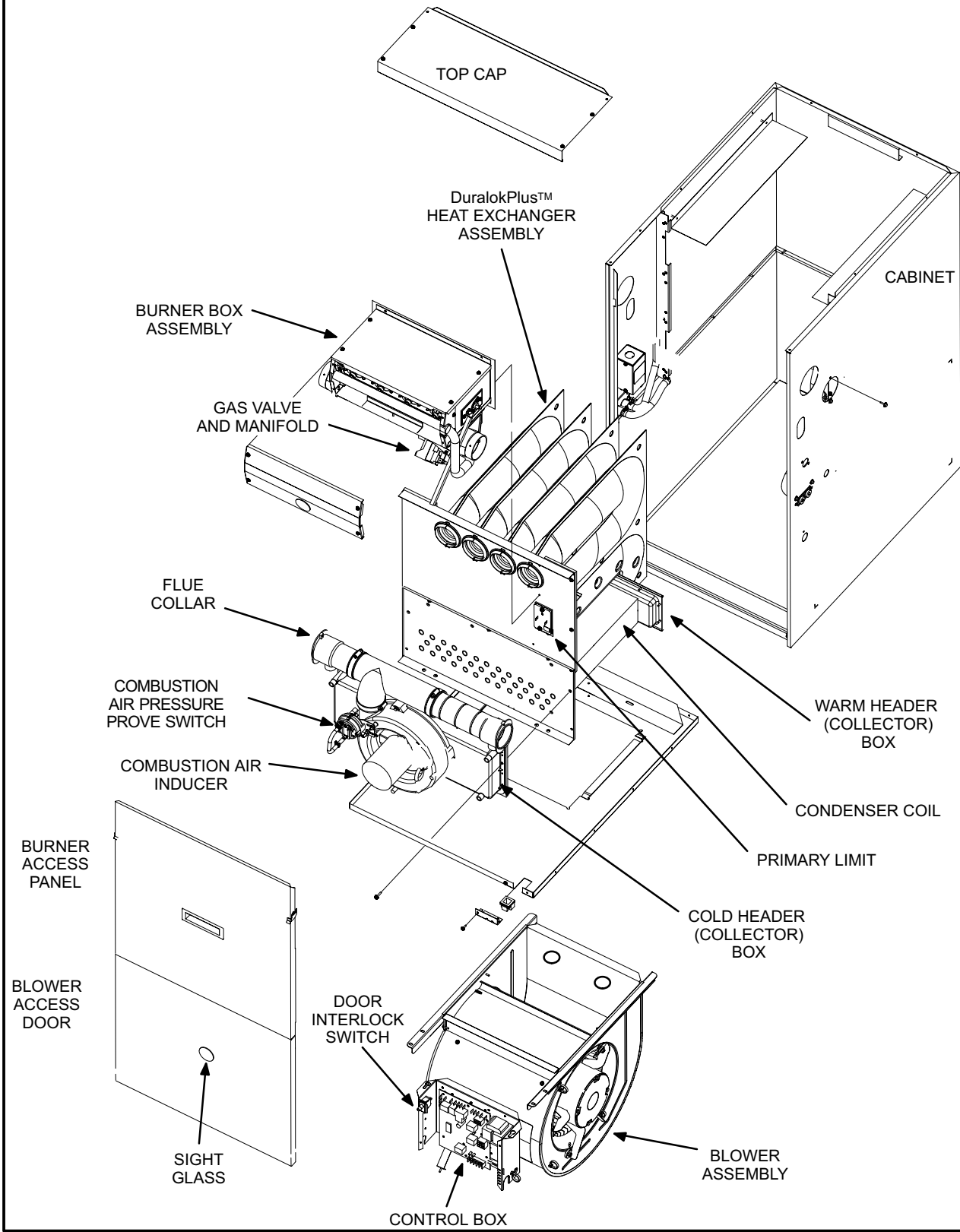


FIGURE 1

## I-UNIT COMPONENTS

G43UF unit components are shown in figure 1. The combustion air inducer, gas valve and burners can be accessed by removing the burner access panel. The blower and control box can be accessed by removing the blower access door. G43UF units are designed for bottom and side return air.

### A-Make-Up Box (Figure 2)

A field make-up box is provided for line voltage wiring. Line voltage wiring to unit is routed from the make up box. The "hot" wire is connected to the door switch and then from the switch to the integrated ignition control. The make-up box may be installed inside or outside the unit and on the unit left or right side (right side shown figure 2).

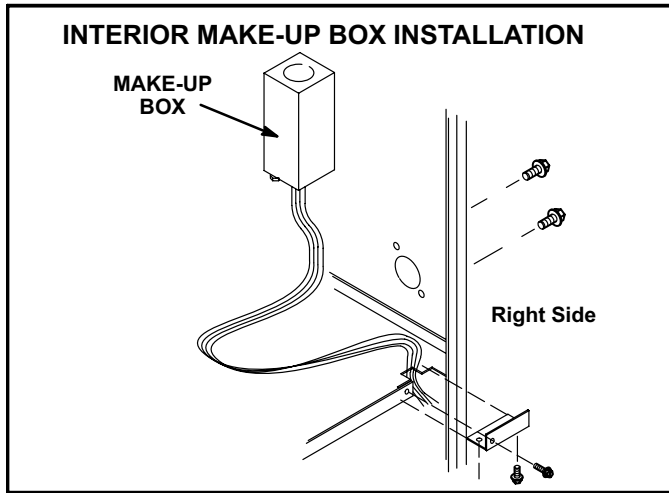


FIGURE 2

### B-Control Box Components (Figure 3)

Unit transformer (T1) and integrated ignition control (A92) are located in the control box. In addition, a door interlock switch (S51) is located in the control box.

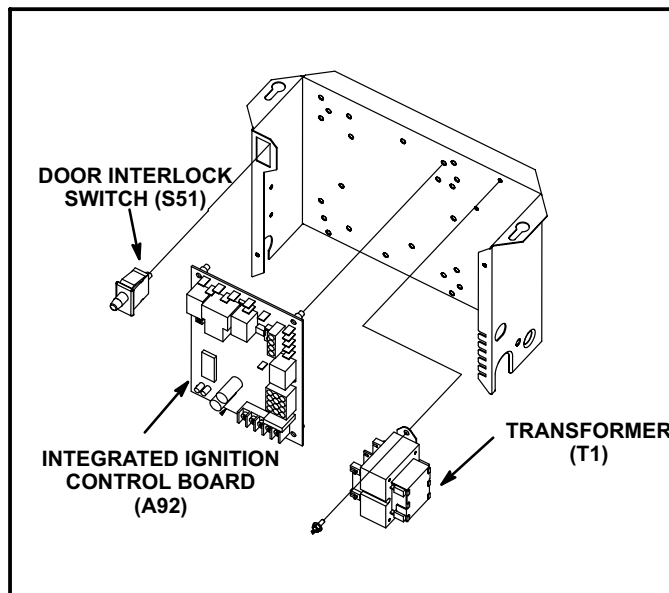


FIGURE 3

### 1. Transformer (T1)

A transformer located in the control box provides power to the low voltage section of the unit. The transformers on all models are rated at 40VA with a 120V primary and 24V secondary.

### 2. Door Interlock Switch (S51)

A door interlock switch rated 14A at 120VAC is located on the control box. The switch is wired in series with line voltage. When the blower door is removed the unit will shut down.

### 3. SureLight® Control 32M88 (A92) G43UF-1 Units

## ⚠ WARNING

Shock hazard.

Disconnect power before servicing. Control is not field repairable. If control is inoperable, simply replace entire control.

Can cause injury or death. Unsafe operation will result if repair is attempted.

## ELECTROSTATIC DISCHARGE (ESD)

### Precautions and Procedures

## ⚠ CAUTION

Electrostatic discharge can affect electronic components. Take precautions during furnace installation and service to protect the furnace's electronic controls. Precautions will help to avoid control exposure to electrostatic discharge by putting the furnace, the control and the technician at the same electrostatic potential. Neutralize electrostatic charge by touching hand and all tools on an unpainted unit surface, such as the gas valve or blower deck, before performing any service procedure.

The SureLight ignition system consists of ignition control board 32M88 (figure 6 with control terminal designations in table 3), ignitor (figure 9) and sensor (figure 10). Control board 32M88 and ignitor work in combination to ensure furnace ignition and ignitor durability. The control board controls all major furnace operations. The control board also features two green LED lights (DS1 and DS2) for troubleshooting and two accessory terminals rated at (1) one amp. Tables 1 and 2 show jack plug terminal designations. See table 4 for troubleshooting diagnostic codes. The SureLight ignitor is made of durable silicon-nitride. Ignitor longevity is also enhanced by voltage ramping by the control board. The control board finds the lowest ignitor temperature which will successfully light the burner, thus increasing the life of the ignitor.

**TABLE 1**

SureLight BOARD J156 (J2) TERMINAL DESIGNATIONS	
PIN #	FUNCTION
1	Combustion Air Inducer Line
2	Ignitor Line
3	Combustion Air Inducer Neutral
4	Ignitor Neutral

**TABLE 2**

SureLight BOARD J58 (J1) TERMINAL DESIGNATIONS	
PIN #	FUNCTION
1	High Limit Output
2	Not Used
3	24V Line
4	Not Used
5	Rollout Switch In
6	24V Neutral
7	High Limit Input
8	Ground
9	Gas Valve In
10	Pressure Switch Out
11	Rollout Switch Out
12	Gas Valve Out

**TABLE 3**

TERMINAL DESIGNATIONS	
COOL-H 120V HOT	Blower Cooling Speed (120VAC)
HEAT-H	Blower Heating Speed-(120VAC)
EAC-H	Electronic Air Cleaner (120VAC)
HUM-H	Humidifier (120VAC)
XFMR-H	Transformer (120VAC)
LINE-H	Input (120VAC)
LINE-N 120V NEUT	Input (Neutral)
HUM-N	Humidifier (Neutral)
EAC-N	Electronic Air Cleaner (Neutral)
XFMR-N	Transformer (Neutral)
CIR-N	Blower (Neutral)
PARK	Alternate Blower Speeds (dead)
(FLAME SENSE)	Flame Sensor

**Electronic Ignition (See Figure 5)**

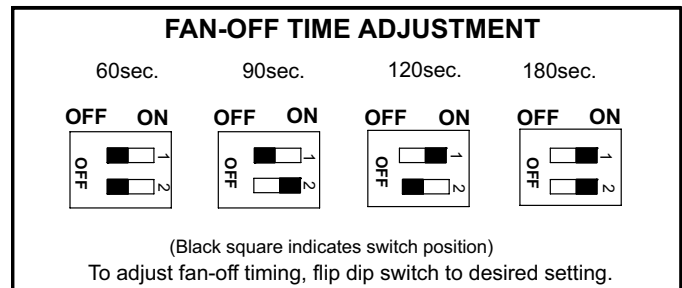
On a call for heat the SureLight® control board monitors the combustion air inducer prove switch. The control will not begin the heating cycle if the prove switch is closed (bypassed). Once the prove switch is determined to be open, the combustion air inducer is energized. When the differential in the prove switch is great enough, the prove switch closes and a 15-second pre-purge begins. If the prove switch is not proven within 2-1/2 minutes, the control goes into Watchguard-Pressure Switch mode for a 5-minute reset period.

After the 15-second pre-purge period, the SureLight ignitor warms up for 20 seconds during which the gas valve opens at 19 seconds for a 4-second trial for ignition. The ignitor stays energized during the 4 second trial until flame is sensed. If ignition is not proved during the 4-second period, the control will try four more times with an inter purge and warm-up time between trials of 35 seconds. After a total of five trials for ignition (including the initial trial), the control goes into Watchguard-Flame Failure mode. After a 60-minute reset period, the control will begin the ignition sequence again.

The SureLight control board has an added feature that prolongs the life of the ignitor. After a successful ignition, the SureLight control utilizes less power to energize the ignitor on successive calls for heat. The control continues to ramp down the voltage to the ignitor until it finds the lowest amount of power that will provide a successful ignition. This amount of power is used for 255 cycles. On the 256th call for heat, the control will again ramp down until the lowest power is determined and the cycle begins again. Each time 120V is removed and then re-applied, the control re-starts the learning process.

**Fan Time Control**

The fan on time of 45 seconds is not adjustable. Fan off time (time that the blower operates after the heat demand has been satisfied) can be adjusted by setting the dip switches located on the control board. The unit is shipped with a factory fan off setting of 90 seconds. For customized comfort, monitor the supply air temperature once the heat demand is satisfied. Note the supply air temperature at the instant the blower is de-energized. Adjust the fan-off delay to achieve a supply air temperature between 90° - 110° at the instant the blower is de-energized. (Longer delay times allow for lower air temperature, shorter delay times allow for higher air temperature). See figure 4.



**FIGURE 4**

The integrated ignition control board is equipped with two LED lights for troubleshooting. The diagnostic codes are listed below in table 4.

**TABLE 4**

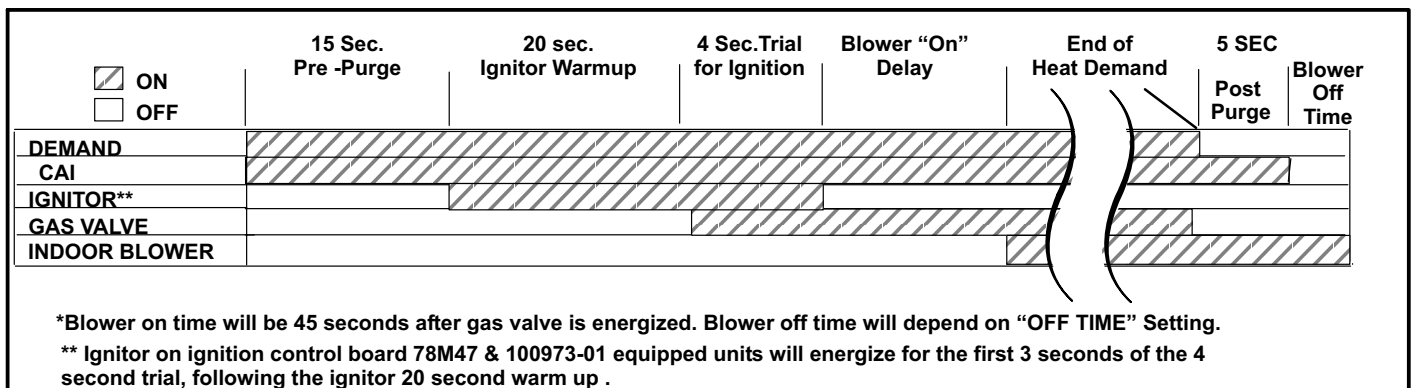
**DIAGNOSTIC CODES**

Make sure to Identify LED'S Correctly..

LED#1 32M88 - DS1 Green 78M47 - DS1 Red	LED #2 32M88 - DS2 Green 78M47 - DS2 Green	DESCRIPTION
SIMULTANEOUS SLOW FLASH	SIMULTANEOUS SLOW FLASH	Power on - Normal operation. Also signaled during cooling and continuous fan.
SIMULTANEOUS FAST FLASH	SIMULTANEOUS FAST FLASH	Normal operation - signaled when heating demand initiated at thermostat.
SLOW FLASH	ON	Primary or secondary limit switch open. Limit must close within 3 minutes or unit goes into 1 hour Watchguard.
OFF	SLOW FLASH	Prove switch open. OR:Blocked inlet/exhaust vent; OR: Prove switch closed prior to activation of combustion air inducer.
ALTERNATING SLOW FLASH	ALTERNATING SLOW FLASH	Watchguard -- burners failed to ignite OR: limit open more than 3 minutes (control board 32M88 Only) OR: lost flame sense 5 times in one heating cycle OR: prove switch opened 5 times in one heating cycle
SLOW FLASH	OFF	Flame sensed without gas valve energized.
ON	SLOW FLASH	Rollout switch open. OR: 12-pin connector improperly attached.
ON ON OFF	ON OFF ON	Circuit board failure or control wired incorrectly.
FAST FLASH	SLOW FLASH	Main power polarity reversed. Switch line and neutral.
SLOW FLASH	FAST FLASH	Low flame signal. Measures below Control board 32M88 - 0.18 microamps Control board 78M47 & 100973-01 - 1.5 microamps Replace flame sense rod.
ALTERNATING FAST FLASH	ALTERNATING FAST FLASH	The following conditions are sensed Improper main ground (control board 32M88) during the ignitor warm-up period ONLY Improper main ground (control board 78M47 & 100973-01) continuously OR: Broken ignitor (control board 32M88) OR: Open ignitor circuit (control board 32M88) OR: Line voltage to control below Control board 32M88 75V Control board 78M47 & 100973-01 90V

NOTE - Slow flash rate equals 1 Hz (one flash per second). Fast flash rate equals 3 Hz (three flashes per second).

Low flame sense current = SureLight Control Board 32M88 0.16 - 0.17 microamps Ignition Control Board 78M47 & 100973-01 0.5 - 1.4 microamps



**FIGURE 5**

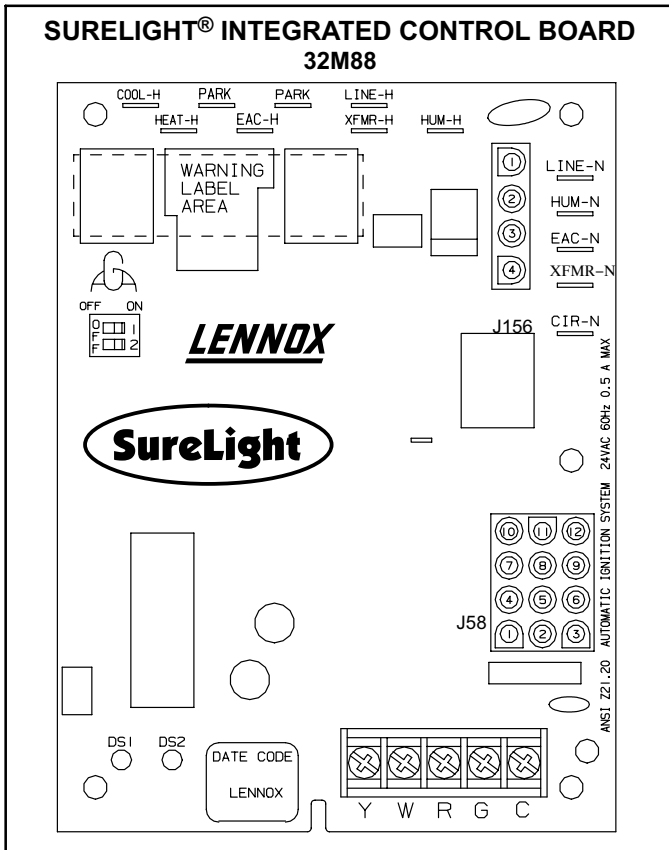


FIGURE 6

#### 4. Ignition Control 78M47 & 100973-01 (A92) G43UF-2 and later units

### ⚠ WARNING

**Shock hazard.**

**Disconnect power before servicing. Control is not field repairable. If control is inoperable, simply replace entire control.**

**Can cause injury or death. Unsafe operation will result if repair is attempted.**

The ignition control system consists of an integrated control board (figure 8 with control terminal designations in table 7), ignitor (figure 9) and sensor (figure 10). The control board and ignitor work in combination to ensure furnace ignition and ignitor durability. The control board controls all major furnace operations. The control board also features two LED lights (DS1 red and DS2 green) for troubleshooting and two accessory terminals rated at (1) one amp. The control board also features a (3) amp fuse for overcurrent protection. Tables 5 and 6 show jack plug terminal designations. See table 4 for troubleshooting diagnostic codes. The mini-nitride ignitor is made from a non-porous, high strength proprietary ceramic material that provides long life and trouble free maintenance. The control board continuously monitors line voltage and maintains the ignitor power at a consistent level to provide proper lighting and maximum ignitor life.

TABLE 5

4-Pin Terminal Designation	
PIN #	FUNCTION
1	Combustion Air Inducer Line
2	Ignitor Line
3	Combustion Air Inducer Neutral
4	Ignitor Neutral

TABLE 6

12-Pin Terminal Designations	
PIN #	FUNCTION
1	High Limit Output
2	Not Used
3	24V Line
4	Not Used
5	Rollout Switch Out
6	24V Neutral
7	High Limit Input
8	Ground
9	Gas Valve Common
10	Prove Switch In
11	Rollout Switch In
12	Gas Valve Out

TABLE 7

TERMINAL DESIGNATIONS	
120 Volt Hot	
COOL	Cool Speed
HEAT	Heat Speed
PARK	Park
PARK	Park
EAC	Electroncic Air Cleaner
XFMR	Transformer
LINE	Line
HUM	Humidifier
120 Volt Neutral	
CIRC	Blower
XMFR	Transformer
HUM	Humidifier
LINE	Line
Flame FS	Flame Signal

#### Electronic Ignition (See Figure 5)

On a call for heat the ignition control board monitors the combustion air inducer prove switch. The control board will not begin the heating cycle if the prove switch is closed (bypassed). Once the prove switch is determined to be open, the combustion air inducer is energized. When the differential in the prove switch is great enough, the prove switch closes and a 15-second pre-purge begins. If the prove switch is not proven within 2-1/2 minutes, the control board goes into Watchguard-Pressure Switch mode for a 5-minute re-set period.

After the 15-second pre-purge period, the ignitor warms up for 20 seconds during which the gas valve opens at 19 seconds for a 4-second trial for ignition. The ignitor remains energized for the first 3 seconds during the 4 second trial. If ignition is not proved during the 4-second period, the control will try four more times with an inter purge and warm-up time between trials of 35 seconds. After a total of five trials for ignition (including the initial trial), the control goes into Watchguard-Flame Failure mode. After a 60-minute reset period, the control will begin the ignition sequence again. The control board has an added feature of ignitor power regulation to maintain consistent lighting and longer ignitor life under all line voltage conditions.

### Fan Time Control

The fan on time of 45 seconds is not adjustable. Fan off time (time that the blower operates after the heat demand has been satisfied) can be adjusted by moving the jumper to a different setting. The unit is shipped with a factory fan off setting of 90 seconds. For customized comfort, monitor the supply air temperature once the heat demand is satisfied. Note the supply air temperature at the instant the blower is de-energized. Adjust the fan-off delay to achieve a supply air temperature between 90° - 110° at the instant the blower is de-energized. (Longer delay times allow for lower air temperature, shorter delay times allow for higher air temperature). See figure 7.

Board 100973-01 only has a 45 second fan off delay after cooling demand is met. This timing is factory set and cannot be adjusted.

FAN-OFF TIME ADJUSTMENT		
JUMPER POSITION		HEAT OFF DELAY
OFF	OFF	180
PIN1	PIN2	60
PIN2	PIN3	90
PIN3	PIN4	120
PIN4	PIN5	180

To adjust fan-off timing, reposition jumper across pins to achieve desired setting.

FIGURE 7

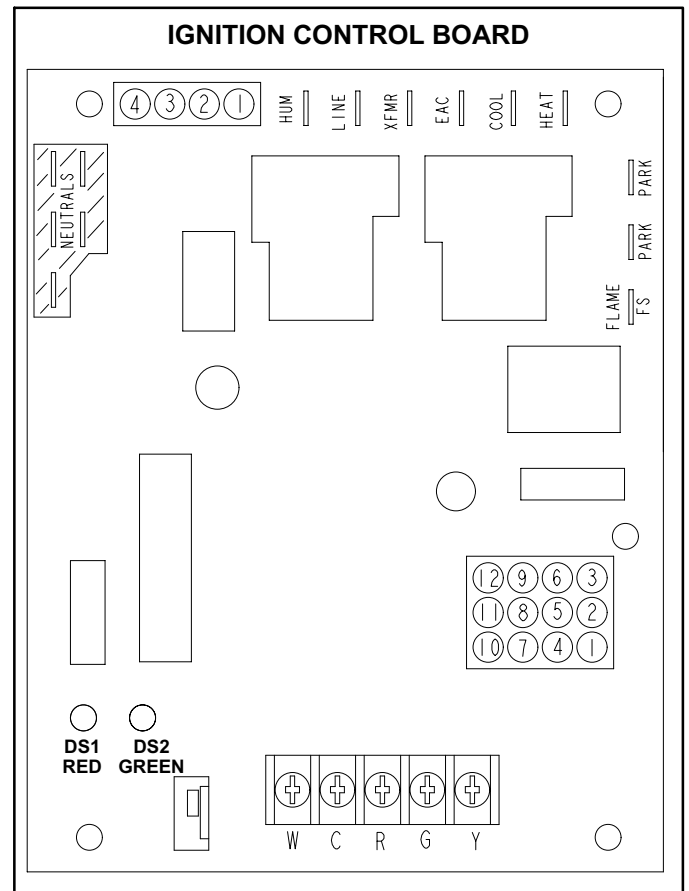


FIGURE 8

## C-Heating Components

Combustion air inducer (B6), primary limit control (S10), SureLight ignitor, burners, flame rollout switch (S47), gas valve (GV1), combustion air prove switch (S18), and clam-shell heat exchangers are located in the heating compartment. The heating compartment can be accessed by removing the burner access panel.

### 1. Ignitor (Figure 9)

The SureLight ignitor used on G43UF-1 units, is made of durable silicon nitride. The board finds the lowest ignitor temperature which will successfully light the burner, thus increasing the life of the ignitor. Due to this feature of the board, voltage cannot be measured. The check ignitor, measure its resistance. A value of 10.9 to 19.7 ohms indicates a good ignitor.

The ignitor used on G43-2 and later units use a mini-nitride ignitor made from a proprietary ceramic material. Ignitor longevity is enhanced by controlling the voltage to the ignitor. The check ignitor, measure its resistance. A value of 50 to 450 ohms indicates a good ignitor.

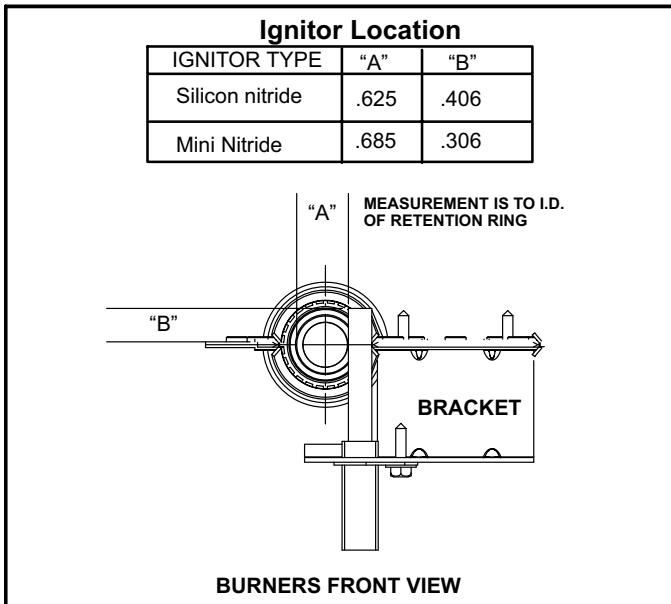


FIGURE 9

## 2. Flame Sensor (Figure 10)

A flame sensor is located on the left side of the burner support. The sensor is mounted on the bottom burner box plate and the tip protrudes into the flame envelope of the left-most burner. The sensor can be removed for service without removing any part of the burners. During operation, flame is sensed by current passed through the flame and sensing electrode. The ignition control allows the gas valve to remain open as long as flame signal is sensed.

*NOTE - The G43UF furnace contains electronic components that are polarity sensitive. Make sure that the furnace is wired correctly and is properly grounded.*

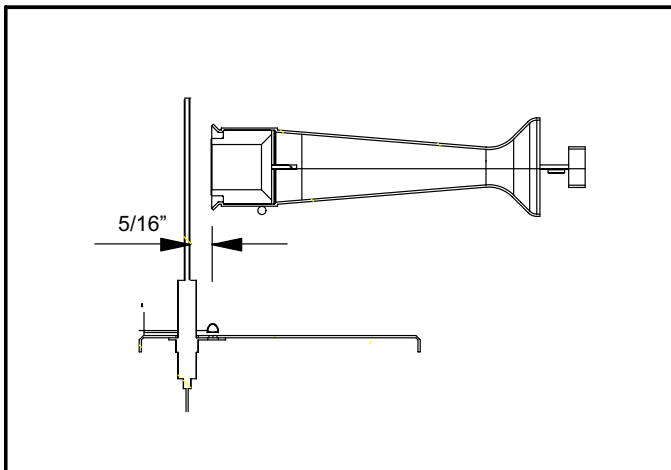


FIGURE 10

## 3. Primary Limit Control (S10)

Figure 11 shows the primary limit (S10) used on G43UF units located in the heating vestibule panel. S10 is provided with a shield on some models (figure 11) and must not be removed. Note orientation of shield and limit if limit is replaced. When excess heat is sensed in the heat exchanger, the limit will open. Once the limit opens, the furnace control energizes the supply air blower and de-energizes the gas valve. The limit automatically resets when unit temperature returns to normal. The switch is factory set and cannot be adjusted.

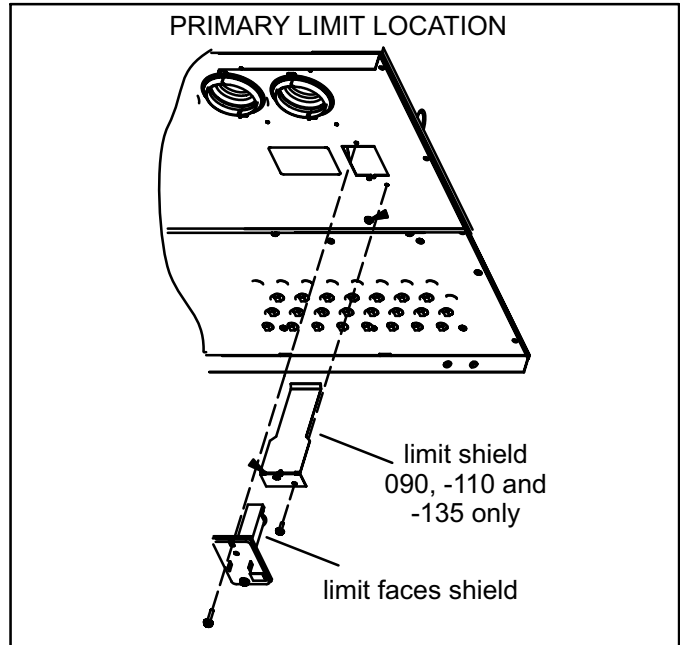


FIGURE 11

## 4. Burners (Figure 12)

All units use inshot burners. Burners are factory set and do not require adjustment. Burners can be removed as an assembly for service. Burner maintenance and service is detailed in the MAINTENANCE section of this manual. Each burner uses an orifice which is precisely matched to the burner input. All G43UF natural gas units are fitted with .089" sized orifices. See table 20 or "SPECIFICATIONS" tables for LP kits and high altitude. The orifice is threaded into the burner manifold.

The burner is supported by the orifice and will easily slide off for service. A flame retention ring in the end of each burner maintains correct flame length and shape and keeps the flame from lifting off the burner head. In addition, the burner entrance to each clamshell is fitted with a corbel cup (orifice) used to direct the flow of combustion products.

*NOTE - Do not use thread-sealing compound on the orifices. Thread-sealing compound may plug the orifices.*

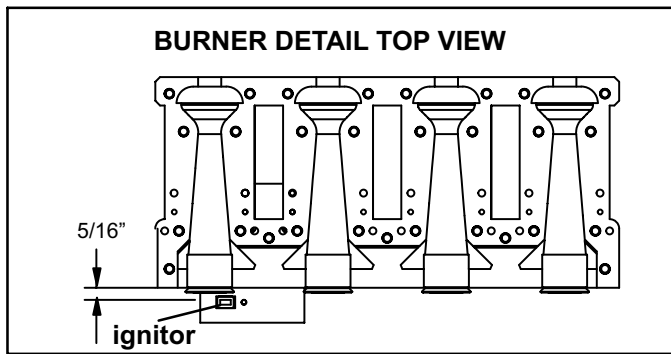


FIGURE 12

## 5. Clamshell Heat Exchanger

G43UF units use an aluminized steel primary and stainless steel secondary heat exchanger assembly. Heat is transferred to the air stream from all surfaces of the heat exchanger. The shape of the heat exchanger ensures maximum efficiency.

The combustion air inducer pulls fresh air through the air intake box. This air is mixed with gas in the burner venturi and at the corbel orifices. The gas / air mixture is then burned at the entrance of each clamshell. Combustion gases are then pulled through the primary and secondary heat exchangers and exhausted out the exhaust vent pipe.

## 6. Backup Secondary Limit Control (S113) (G43UF-090, 110, 135 only)

Backup secondary limit control S113 is a N.C. auto-reset switch located on the combustion air inducer. S113 acts as a backup to primary limit S10 in the event of an indoor blower failure. S113 contacts open when temperature on the CAI reaches 142°.

## 7. Flame Rollout Switches (S47)

Flame rollout switches S47 are SPST N.C. high temperature limits located on each side of the burner box assembly (see figure 13). S47 is wired to the burner ignition control A92. When either of the switches sense flame rollout (indicating a blockage in the combustion passages), the flame rollout switch trips, and the ignition control immediately closes the gas valve. Switch S47 in all G43UF units is factory preset to open at 250°F ± 12°F (121°C ± 6.7°C) on a temperature rise. All flame rollout switches are manual reset.

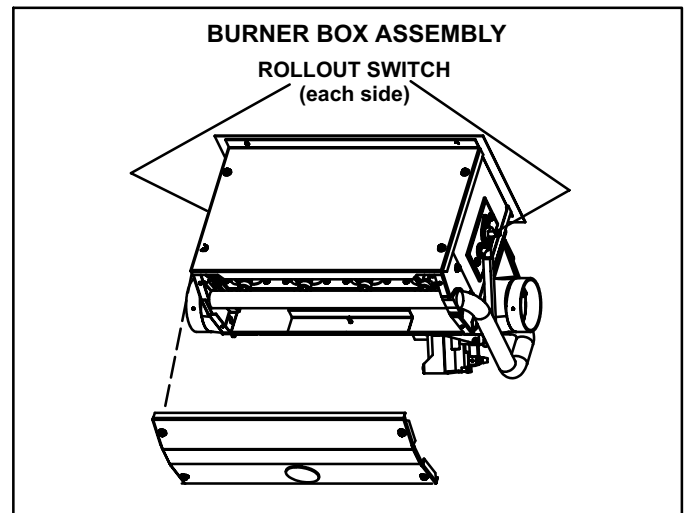


FIGURE 13

## 8. Gas Valve (GV1)

The G43UF uses a gas valve manufactured by Honeywell or White Rodgers (see figure 14 ). The valves are internally redundant to assure safety shut-off. If the gas valve must be replaced, the same type valve must be used.

24VAC terminals and gas control knob are located on top of the valve. All terminals on the gas valve are connected to wires from the ignition control. 24V applied to the terminals opens the valve.

Inlet and outlet pressure taps are located on the valve. A manifold adjustment screw is also located on the valve.

An LPG changeover kit is available. See table 20. For units equipped with the Honeywell VR205 valve, the kit includes a low pressure switch that must be installed in the valve as shown in figure 14.

The burner box is sealed and operates under a negative pressure. A pressure hose is connected from the burner box to the gas valve. The gas valve senses the pressure in the burner box and changes gas valve outlet (manifold) pressure based on changes in the burner box pressure. The intent is to compensate for different vent configurations which can greatly affect the rate of the unit.

## ▲ IMPORTANT

The White Rodgers 36G gas valve (figure 14) is equipped with pressure posts for measuring supply and manifold pressures. The posts provide built-in hose connections and have an integral 3/32" Allen-head screw. Rotate the screw counterclockwise one full turn to permit pressure measurement. Reseat the screw (rotate one full turn clockwise) after measurements have been taken to prevent gas leakage.

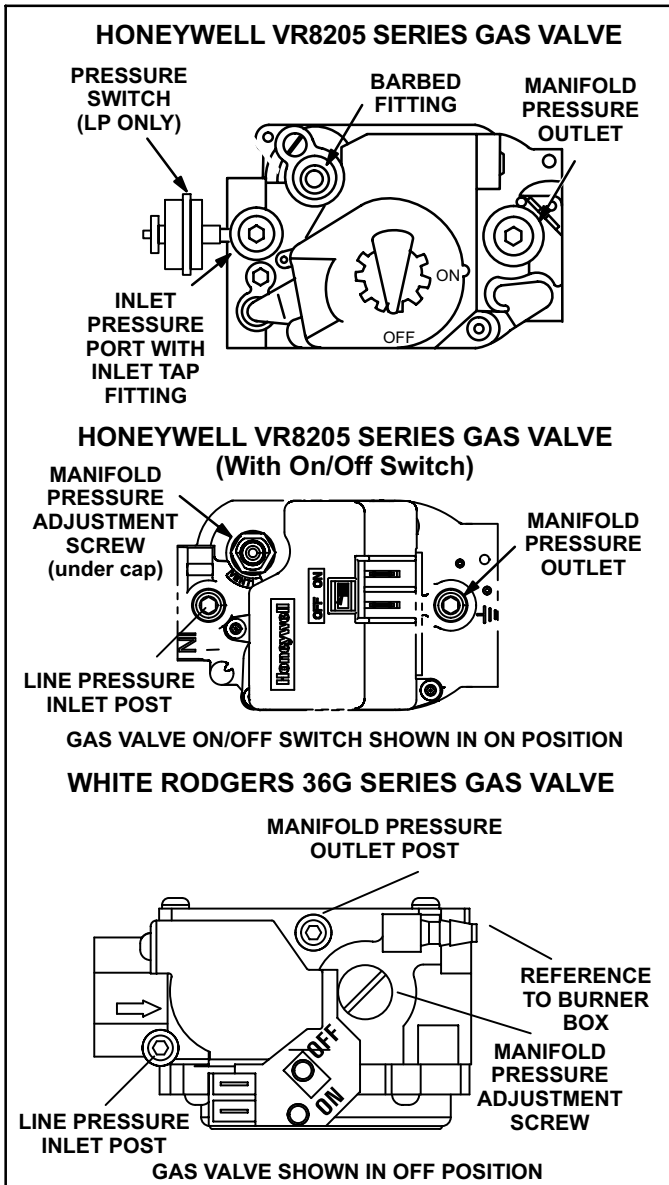


FIGURE 14

## 9. Combustion Air Inducer (B6) & Cold End Header Box

All G43UF units use a combustion air inducer to move air through the burners and heat exchanger during heating operation. The blower uses a shaded pole 120VAC motor. The motor operates during all heating operation and is controlled by burner ignition control A3. Blower operates

continuously while there is a call for heat. The burner ignition control will not proceed with the ignition sequence until combustion air inducer operation is sensed by the proving switches.

The CAI is installed on the cold end header box. The cold end header box is a single piece made of hard plastic. The box has an internal channel where the combustion air inducer creates negative pressure at unit start up. The channel contains an orifice used to regulate flow created by the CAI. The box has pressure taps for the CAI prove switch hoses. The prove switch measure the pressure across the CAI orifice or difference in the channel and the box. A window is provided on the bottom right hand side of the box to indicate orifice size. See figures 15 and 17. See table 8 for orifice size per unit. **If replacement is necessary the gaskets used to seal the box to the vestibule panel and the CAI to the box, must also be replaced.**

### **⚠ WARNING**

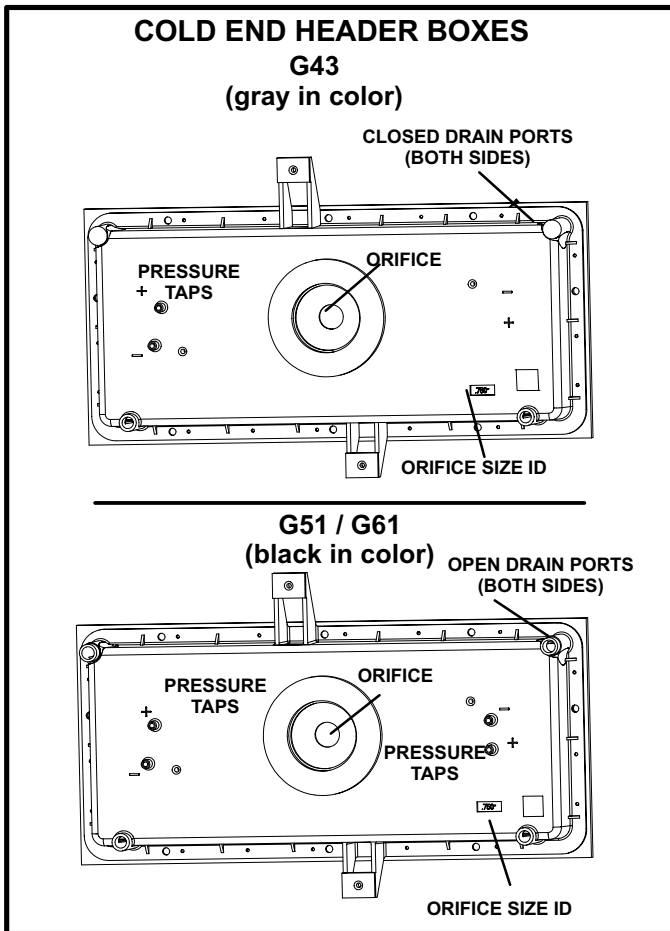
#### **CARBON MONOXIDE POISONING HAZARD**

Do not install a header box designed for the G51 or G61 furnace onto a G43 furnace. Header boxes for G51 and G61 furnaces are equipped with open drain ports in the upper corners of the box, which allow bypass of the proper flow of combustion air to the burners. Differences in header box are shown in figure 15.

When replacing a G43 header box, ensure that the replacement box is equipped with the same orifice size and number of drain and pressure ports as the original. G43 header boxes are GRAY in color. G51 and G61 series header boxes are BLACK in color.

TABLE 8

G43UF Unit	C.A.I. Orifice Size
-045-1 to -6	.750"
-045-7 and later	.703"
-070-7 and later	.922"
-070-1 to -6	.969"
-090	1.063"
-110	1.344"
-135	1.625"

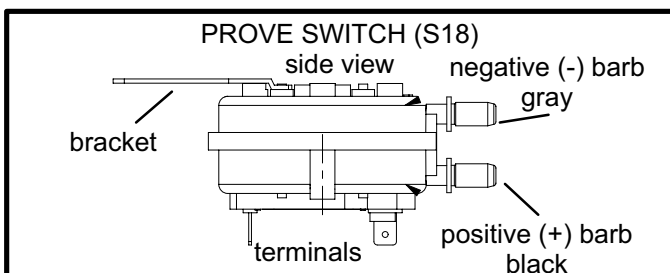


**FIGURE 15**

## 10. Combustion Air Prove Switch (S18)

G43UF series units are equipped with a differential prove switch located on the combustion air inducer housing. See figures 16 and 17. One side of the switch is gray (negative hose barb) and the other side is black (positive hose barb). The switches monitor across the CAI orifice to insure proper flow through the heat exchanger.

The switch is a SPST N.O. prove switch electrically connected to the integrated control. The purpose of the switch is to prevent burner operation if the combustion air inducer is not moving enough air for proper combustion.



**FIGURE 16**

On start-up, the switch senses that the combustion air inducer is operating. It closes a circuit to the ignition control when the difference in pressure across the CAI orifice exceeds a non-adjustable factory setting. If the switch does not successfully sense the required differential, the switch cannot close and the furnace cannot operate. If the flue or air inlet become obstructed during operation, the switch senses a loss of pressure differential and opens the circuit to the ignition control. If the condensate line is blocked, water will back up into the header box and reduce the pressure differential across the switch. The prove switch opens if the differential drops below the set point. See table 9.

Checks of pressure differential can aid in troubleshooting. When measuring the pressure differential, readings should be taken at the prove switch. Lack of differential usually indicates problems in the intake or exhaust piping, but may indicate problems in the heat exchanger, condensing coil, header boxes, combustion inducer or other components.

**TABLE 9**

G43UF	Altitude ft		
	0 - 4500	4501 - 7500	7501 - 10000
	Set Point (Pa)	Set Point (Pa)	Set Point (Pa)
-045-7 and later	1.10" (274)	1.10" (274)	1.00" (249)
-045-1 to -6 units	.95" (236)	.95" (236)	.85" (211)
-070-7 and later	1.00" (249)	.95" (236)	.85" (211)
-070-1 to -6 units	.95" (236)	.95" (236)	.85" (211)
-090	.85" (211)	.75" (186)	.65" (162)
-110			
-135	.65" (162)	.55" (137)	.45" (112)

\*Set point is factory set and non-adjustable

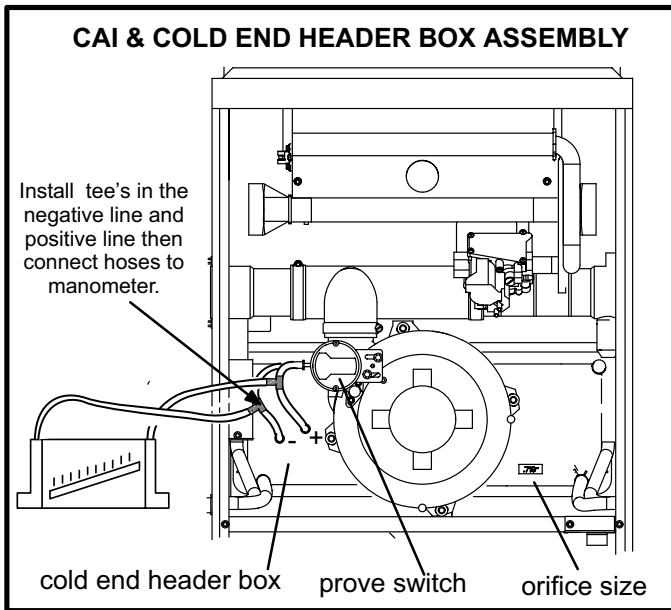
\*\*See table 20 for high altitude kits.

### Measuring pressure differential

The differential pressure is the difference in pressure measured across the cold end header box orifice.

- 1 - Remove thermostat demand and allow unit to cycle off.
- 2 - Install a tee in the negative (-) line and a tee in the positive (+) line running from the prove switch to the cold end header box.
- 3 - Install a manometer with hose from the negative (-) side of the manometer to the tee installed in the negative (-) line and with hose from the positive (+) side of the manometer to the tee in the positive (+) line.

*NOTE - Both sides of the cold end header box are negative. However the (+) port reads less negative pressure than the (-) port.*



**FIGURE 17**

- 4 - Operate unit and observe draft gauge reading. *Readings will change as heat exchanger warms.*
  - a. Take one reading immediately after start-up.
  - b. Take a second reading after unit has reached steady state (approximately 5 minutes). This will be the pressure differential.

**The pressure differential should be greater than those listed in table 9.**

- 5 - Remove thermostat demand and allow to cycle off.
- 6 - Remove manometer and tee's. Reinstall combustion air sensing hoses to the prove switch.

### **D-Blower Compartment**

Blower motor (B3) and capacitor (C4), are located in the blower compartment. The blower compartment can be accessed by removing the blower access panel.

#### **1. Blower Motor (B3) and Capacitor (C4)**

All G43UF units use single-phase direct-drive blower motors. All motors are 120V permanent split capacitor motors to ensure maximum efficiency. See SPECIFICATIONS table at the front of this manual for more detail. See motor nameplate for capacitor ratings.

## II-PLACEMENT AND INSTALLATION

Table 10 lists the available exhaust termination kits. All Lennox vent terminations are PVC or ABS.

**TABLE 10  
TERMINATION KITS**

UNIT MODEL	VENT PIPE DIA. (in.)	Vent Pipe Length Equivalency (feet)								
		Outdoor Exhaust Accelerator (Dia. X Length)	Outdoor Exhaust Accelerator (Dia. X Length)	1-1/2" Concentric Kit	2" Concentric Kit	3" Concentric Kit	2" Wall Plate Kit	3" Wall Plate Kit	2" Wall Kit with Vent Extension	2" Wall Ring Kit
		1-1/2" X 12"	2" X 12"	71M80	60M29	60L46	22G44	44J40 81J20	30G28	15F74
24B-045 36B-045	2	4	Not Allowed	12	Not Allowed	Not Allowed	4	4*	4	4
	2-1/2	5	Not Allowed	15	Not Allowed	Not Allowed	5	5*	5	5
	3	7	Not Allowed	21	Not Allowed	Not Allowed	7	7*	7	7
	4	14	Not Allowed	42	Not Allowed	Not Allowed	14	14*	14	14
36B-070	2	4	Not Allowed	12	Not Allowed	Not Allowed	4	4*	4	4
	2-1/2	5	Not Allowed	15	Not Allowed	Not Allowed	5	5*	5	5
	3	8	Not Allowed	24	Not Allowed	Not Allowed	8	8*	8	8
	4	14	Not Allowed	42	Not Allowed	Not Allowed	14	14*	14	14
36C-090 48C-090	2	Not Allowed	1	Not Allowed	3	3	Not Allowed	1	Not Allowed	1**
	2-1/2	Not Allowed	2	Not Allowed	6	6	Not Allowed	2	Not Allowed	2**
	3	Not Allowed	2	Not Allowed	6	6	Not Allowed	2	Not Allowed	2**
	4	Not Allowed	4	Not Allowed	12	12	Not Allowed	4	Not Allowed	4**
48C-110 60C-110	2	Not Allowed	1	Not Allowed	3	3	Not Allowed	1	Not Allowed	1**
	2-1/2	Not Allowed	2	Not Allowed	6	6	Not Allowed	2	Not Allowed	2***
	3	Not Allowed	2	Not Allowed	6	6	Not Allowed	2	Not Allowed	2***
	4	Not Allowed	4	Not Allowed	12	12	Not Allowed	4	Not Allowed	4***
60D-135	3	Not Allowed	6	Not Allowed	Not Allowed	15	Not Allowed	6	Not Allowed	6***
	4	Not Allowed	10	Not Allowed	Not Allowed	25	Not Allowed	10	Not Allowed	10***

\*Requires field-provided and installed 1-1/2" exhaust accelerator.

\*\*Requires field-provided and installed 2" exhaust accelerator.

\*\*\*For use only in non-direct vent applications, when snow riser is not required. Requires field-provided and installed 2" exhaust accelerator.

\*\*\*For use only in non-direct vent applications.

## A-Vent Piping Guidelines

The G43UF can be installed as either a **Non-Direct Vent** or a **Direct Vent** gas central furnace.

*NOTE - In Non-Direct Vent installations, combustion air is taken from indoors and flue gases are discharged outdoors. In Direct Vent installations, combustion air is taken from outdoors and flue gases are discharged outdoors.*

*Intake and exhaust pipe sizing in Direct Vent applications and exhaust pipe sizing in Non-Direct Vent applications – Size pipe according to tables 11, 12 (direct vent) and 13 (non-direct vent). Table 11 lists the minimum equivalent vent pipe lengths permitted. Tables 12 and 13 list the maximum equivalent pipe lengths permitted.*

**Maximum vent length is defined as:**

- Total length (linear feet) of pipe,
- Plus** Equivalent length (feet) of fittings,
- Plus** Equivalent length (feet) of termination.

**NOTE - Include ALL pipe and ALL fittings, both in doors and outdoors.**

Regardless of the diameter of pipe used, the standard roof and wall terminations described in section *Exhaust Piping Terminations* should be used. Exhaust vent termination pipe is sized to optimize the velocity of the exhaust gas as it exits the termination. Refer to table 14.

*NOTE - The exhaust pipe should be offset a minimum of 12 inches to avoid the possibility of water droplets being released from the exhaust termination. The minimum exhaust vent length is 15 ft. Shorter exhaust vent lengths may result in the discharge of water droplets from the exhaust termination, in spite of the 12-inch vertical offset.*

Each 90° elbow (including those provided with the furnace) of any diameter is equivalent to 5 feet (1.52m) of vent pipe of the same diameter. Two 45° elbows are equivalent to one 90° elbow of the same diameter. One 45° elbow is equal to 2.5 feet (.76m) of vent pipe of the same diameter. In some applications which permit the use of several different sizes of vent pipe, a combination vent pipe may be used. Contact the Application Department for assistance in sizing vent pipe in these applications.

*NOTE - The flue collar on all models is sized to accommodate 2" Schedule 40 flue pipe. When vent pipe which is larger than 2" must be used in an upflow application, a 2" elbow must be applied at the flue collar in order to properly transition to the larger diameter flue pipe. This elbow must be added to the elbow count used to determine acceptable vent lengths. Assign an equivalent feet value to this elbow according to the larger size pipe being used. Contact the Application Department for more information concerning sizing of vent systems which include multiple pipe sizes.*

Use the following steps to correctly size vent pipe diameter.

- 1 - Determine the vent termination and its corresponding equivalent feet value according to table 10.
- 2 - Determine the number of 90° elbows required for both indoor and outdoor (e.g. snow riser) use. Calculate the corresponding equivalent feet of vent pipe.
- 3 - Determine the number of 45° elbows required for both indoor and outdoor use. Calculate the corresponding equivalent feet of vent pipe.
- 4 - Determine the length of straight pipe required.
- 5 - Add the total equivalent feet calculated in steps 1 through 4 and compare that length to the maximum values given in table 12 or 13 for the proposed vent pipe diameter. If the total equivalent length required exceeds the maximum equivalent length listed in the appropriate table, evaluate the next larger size pipe.

### **IMPORTANT**

**Do not use screens or perforated metal in exhaust terminations. Doing so will cause freeze-ups and may block the terminations.**

**TABLE 11  
MINIMUM VENT PIPE LENGTHS**

G43UF MODEL	MIN. EQUIV. VENT LENGTH	EXAMPLE
045, 070, 090	15 ft.*	5 ft. plus 2 elbows of 2", 2-1/2", 3" or 4" diameter pipe
110**		5 ft. plus 2 elbows of 2-1/2" 3" or 4" diameter pipe
135***		5 ft. plus 2 elbows of 3" or 4" diameter pipe

\*Any approved termination may be added to the minimum equivalent length listed.

\*\*G43UF-48C-110 and G43UF-60C-110 must have 90° street ell (supplied) installed directly into unit flue collar.

\*\*\*G43UF-60D-135 must have 3" to 2" reducing ell (supplied) installed directly into unit flue collar.

**TABLE 12  
MAXIMUM VENT PIPE LENGTHS DIRECT VENT (2 PIPE)**

ALTITUDE	G43UF MODEL	MAXIMUM EQUIVALENT VENT LENGTH FEET			
		2" dia.	2-1/2" dia.	3" dia.	4" dia.
<b>0 - 2000 (0 - 609 m)</b>	045	110	135	160	250
	045 -1 to -6	59	80	107	234
	070	70	135	160	250
	070 -1 to -6	59	80	108	214
	090	50	100	125	225
	090-1	26	42	72	204
	110*	30	70	125	200
	110* -1, -2	n/a	32	72	179
	135**	n/a	n/a	***125	180
	135** -1, -2	n/a	n/a	61	160
<b>2001 - 4500 (610 - 1371 m)</b>	045	110	135	160	250
	045 -1 to -6	59	80	107	234
	070	70	135	160	250
	070 -1 to -6	59	80	108	214
	090	50	100	125	225
	09-1	26	42	72	204
	110*	20	70	125	200
	110 -1, -2	n/a	32	72	179
	135**	n/a	n/a	***90	180
	135** -1, -2	n/a	n/a	61	160
<b>4501-7500 (1372-2286 m)</b>	045	110	135	160	250
	045 -1 to -6	59	65	77	234
	070	70	135	160	250
	070 -1 to -6	59	65	78	214
	090-1	26	42	72	204
	090	30	100	125	225
	110*	n/a	70	125	200
	110* -1, -2	n/a	32	72	179
	135**	n/a	n/a	***90	180
	135** -1, -2	n/a	n/a	61	160
<b>7501 - 10000 (2287 - 3048 m)</b>	045	110	135	160	250
	045 -1 to -6	59	65	77	234
	070	70	135	160	250
	070 -1 to -6	59	65	78	214
	090	n/a	100	125	225
	090-1	26	42	72	204
	110*	n/a	70	125	200
	110* -1, -2	n/a	32	72	179
	135**	n/a	n/a	***90	180
	135** -1, -2	n/a	n/a	61	160

\*G43UF-48C-110 and G43UF-60C-110 must have 90° street ell (supplied) installed directly into unit flue collar.

\*\*G43UF-60D-135 must have 3" to 2" reducing ell (supplied) installed directly into unit flue collar.

\*\*\*90° elbows used in configuration of G43UF-60D-135 vent, must be limited to 3" sweep elbows.

**TABLE 13  
MAXIMUM VENT PIPE LENGTHS NON-DIRECT (1 PIPE)**

ALTITUDE	G43UF MODEL	MAXIMUM EQUIVALENT VENT LENGTH FEET			
		2" dia.	2-1/2" dia.	3" dia.	4" dia.
<b>0 - 2000 (0 - 609 m)</b>	045	110	135	160	250
	045 -1 to -6	104	120	137	234
	070	70	135	160	250
	070 -1 to -6	84	110	138	214
	090	50	100	125	225
	090-1	26	42	72	204
	110*	30	70	125	200
	110* -1, -2	n/a	32	72	179
	135**	n/a	n/a	***125	180
	135** -1, -2	n/a	n/a	61	160
<b>2001 - 4500 (610 - 1371 m)</b>	045	110	135	160	250
	045 -1 to -6	104	120	137	234
	070	70	135	160	250
	070 -1 to -6	84	110	138	214
	090	50	100	125	225
	090-1	26	42	72	204
	110*	20	70	125	200
	110* -1, -2	n/a	32	72	179
	135**	n/a	n/a	***90	180
	135** -1, -2	n/a	n/a	61	160
<b>4501 - 7500 (1372 - 2286 m)</b>	045	110	135	160	250
	045 -1 to -6	59	65	77	234
	070	70	135	160	250
	070 -1 to -6	59	65	78	214
	090	30	100	125	225
	090-1	26	42	72	204
	110*	20	70	125	200
	110* -1, -2	n/a	32	72	179
	135**	n/a	n/a	***90	180
	135** -1, -2,	n/a	n/a	61	160
<b>7501 - 10000 (2287 - 3048 m)</b>	045	110	135	160	250
	045 -1 to -6	59	65	77	234
	070	70	135	160	250
	070 -1 to -6	59	65	78	214
	090	n/a	100	125	225
	090-1	26	42	72	204
	110*	n/a	70	125	200
	110* -1, -2	n/a	32	72	179
	135**	n/a	n/a	***90	180
	135** -1, -2	n/a	n/a	61	160

\*G43UF-48C-110 and G43UF-60C-110 must have 90° street ell (supplied) installed directly into unit flue collar.

\*\*G43UF-60D-135 must have 3" to 2" reducing ell (supplied) installed directly into unit flue collar.

\*\*\*90° elbows used in configuration of G43UF-60D-135 vent, must be limited to 3" sweep elbows.

## B-Joint Cementing Procedure

All cementing of joints should be done according to the specifications outlined in ASTM D 2855.

### **⚠ WARNING**

#### **DANGER OF EXPLOSION!**

**Fumes from PVC glue may ignite during system check. Allow fumes to dissipate for at least 5 minutes before placing unit into operation.**

- 1 - Measure and cut vent pipe to desired length.
- 2 - Deburr and chamfer end of pipe, removing any ridges or rough edges. If end is not chamfered, edge of pipe may remove cement from fitting socket and result in a leaking joint.
- 3 - Clean and dry surfaces to be joined.
- 4 - Test fit joint and mark depth of fitting on outside of pipe.
- 5 - Uniformly apply liberal coat of PVC primer for PVC or ABS cleaner for ABS to inside socket surface of fitting and male end of pipe to depth of fitting socket.
- 6 - Promptly apply solvent cement to end of pipe and inside socket surface of fitting. Cement should be applied lightly but uniformly to inside of socket. Take care to keep excess cement out of socket. Apply second coat to end of pipe.

*NOTE - Time is critical at this stage. Do not allow primer to dry before applying cement.*

- 7 - Immediately after applying last coat of cement to pipe, and while both inside socket surface and end of pipe are wet with cement, forcefully insert end of pipe into socket until it bottoms out. Turn pipe 1/4 turn during assembly (but not after pipe is fully inserted) to distribute cement evenly.

*NOTE - Assembly should be completed within 20 seconds after last application of cement. Hammer blows should not be used when inserting pipe.*

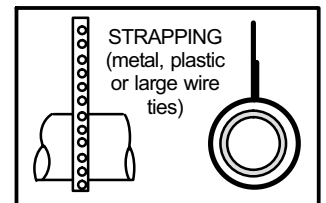
- 8 - After assembly, wipe excess cement from pipe at end of fitting socket. A properly made joint will show a bead around its entire perimeter. Any gaps may indicate a defective assembly due to insufficient solvent.
- 9 - Handle joints carefully until completely set.

## C-Venting Practices

The thickness of construction through which vent pipes may be installed is 24" (610mm) maximum and 3/4" (19mm) minimum. If a G43UF furnace replaces a furnace which was commonly vented with another gas appliance, the size of the existing vent pipe for that gas appliance must be checked. Without the heat of the original furnace flue products, the existing vent pipe is probably oversized for the single water heater or other appliance. The vent should be checked for proper draw with the remaining appliance.

1. Use recommended piping materials for exhaust piping.
2. Secure all joints, including drip leg, gas-tight using approved cement.

Suspend piping using hangers at a minimum of every 5 feet (1.52m) for schedule 40 PVC and every 3 feet (.91m) for ABS-DWV, PVC-DWV, SPR-21 PVC, and SDR-26 PVC piping. A suitable hanger can be fabricated by using metal or plastic strapping or a large wire tie.



**FIGURE 18**

3. In areas where piping penetrates joists or interior walls, hole must be large enough to allow clearance on all sides of pipe through center of hole using a hanger.
4. Secure piping at the point where it exits the outside wall or roof in order to prevent transmission of vibration to the structure.
5. When furnace is installed in a residence where unit is shut down for an extended period of time, such as a vacation home, make provisions for draining condensate collection trap and lines.

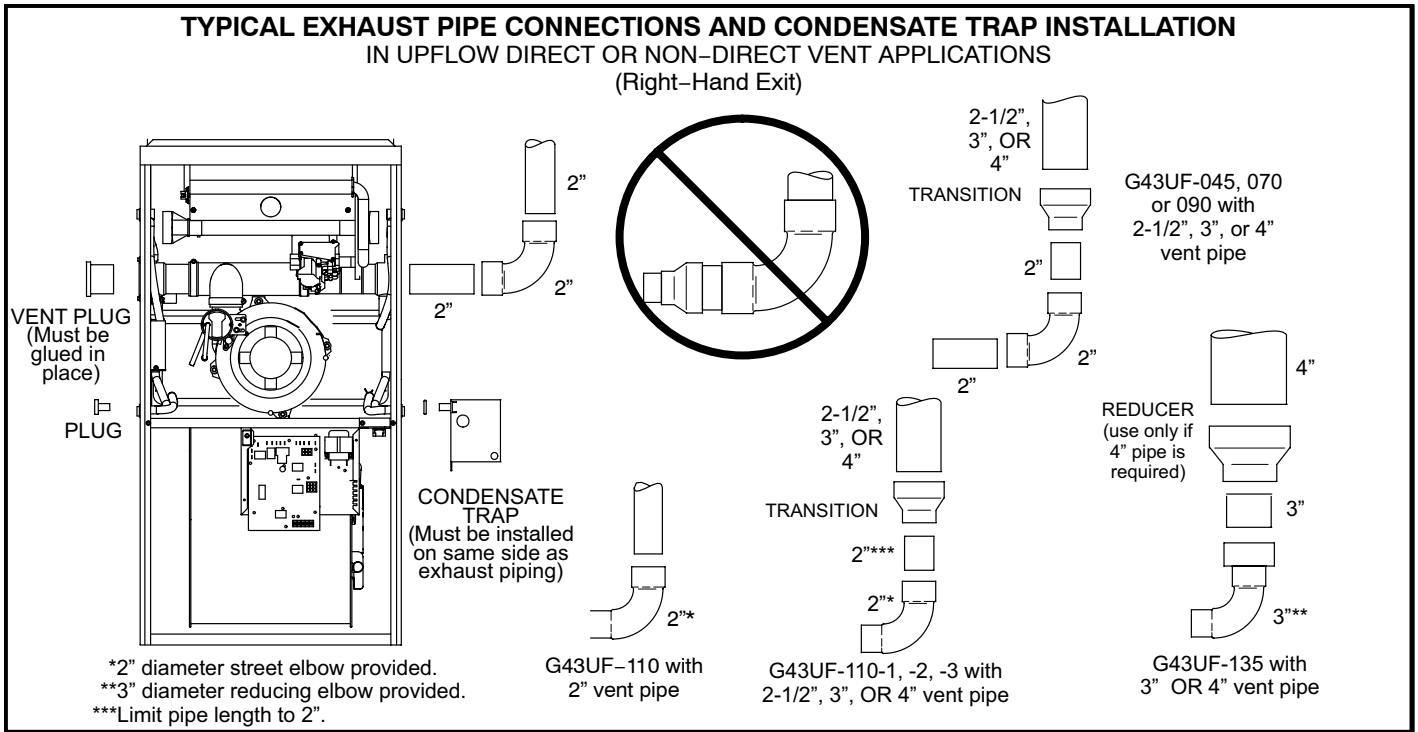


FIGURE 19

### Exhaust Piping

NOTE - A 2" diameter street ell is strapped to the blower deck of 48C-110 and 60C-110 units. Street ell **must be** glued directly into the unit flue collar. See figure 19. A 3" to 2" reducing ell is strapped to the blower deck of the 60D-135 units. The reducing ell **must be** glued directly into the unit flue collar.

1. Choose the appropriate side for venting. Glue the field-provided exhaust vent pipe (or provided street ell) to the flue collar. All cement joints should be made according to the specifications outlined in ASTM D 2855. Refer to pipe and fittings specifications and gluing procedures.

### IMPORTANT

Exhaust piping and condensate trap must be installed on the same side of the unit.

2. All horizontal runs of exhaust pipe must slope back toward unit. A minimum of 1/4" (6mm) drop for each 12" (305mm) of horizontal run is mandatory for drainage. Horizontal runs of exhaust piping must be supported every 5 feet (1.52m) using hangers.

NOTE - Exhaust piping should be checked carefully to make sure there are no sags or low spots.

3. On the opposite side of the cabinet, glue the provided 2" vent plug into the unused flue collar.
4. Route piping to outside of structure. Continue with installation following instructions given in piping termination section.

### CAUTION

Do not discharge exhaust into an existing stack or stack that also serves another gas appliance. If vertical discharge through an existing unused stack is required, insert PVC pipe inside the stack until the end is even with the top or outlet end of the metal stack.

### CAUTION

The exhaust vent pipe operates under positive pressure and must be completely sealed to prevent leakage of combustion products into the living space.

### Exhaust Pipe Offset

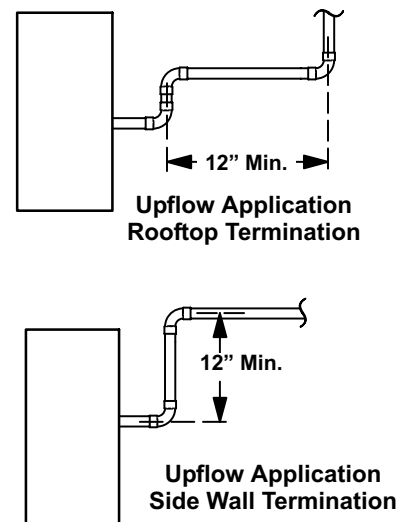


FIGURE 20



Follow the next three steps when installing the unit in **Non-Direct Vent applications** where combustion air is taken from indoors and flue gases are discharged outdoors.

- 1 - Use field-provided materials and the factory-provided air intake screen to route the intake piping as shown in figure 22. Maintain a minimum clearance of 3" (76mm) around the air intake opening. The air intake opening (with the protective screen) should always be directed either downward or straight out. Use 2" pipe and fittings only and make sure that the air intake does not extend more than 6" beyond the G43UF cabinet.

**The air intake connector must not be located near the floor.**

- 2 - Use a sheet metal screw to secure the intake pipe to the connector, if desired. A pilot indentation is provided in the slip connector to assist in locating and starting the fastener.
- 3 - Glue the provided 2" plug into the unused air intake connector on the opposite side of the cabinet.

#### **Testing for Proper Venting and Sufficient Combustion Air (Non-Direct Vent Applications Only)**

### **WARNING**

#### **CARBON MONOXIDE POISONING HAZARD!**

**Failure to follow the steps outlined below for each appliance connected to the venting system being placed into operation could result in carbon monoxide poisoning or death.**

**The following steps shall be followed for each appliance connected to the venting system being placed into operation, while all other appliances connected to the venting system are not in operation.**

After the G43UF gas furnace has been started, the following test should be conducted to ensure proper venting and sufficient combustion air has been provided to the G43UF, as well as to other gas-fired appliances which are separately vented. The test should be conducted while all appliances (both in operation and those not in operation) are connected to the venting system being tested. If the venting system has been installed improperly, or if provisions have not been made for sufficient amounts of combustion air, corrections must be made as outlined in the previous section.

- 1 - Seal any unused openings in the venting system.
- 2 - Visually inspect the venting system for proper size and horizontal pitch. Determine there is no blockage or restriction, leakage, corrosion, or other deficiencies which could cause an unsafe condition.
- 3 - To the extent that it is practical, close all building doors and windows and all doors between the space in which the appliances connected to the venting system are located and other spaces of the building.
- 4 - Close fireplace dampers.
- 5 - Turn on clothes dryers and any appliances not connected to the venting system. Turn on any exhaust fans, such as range hoods and bathroom exhausts, so they will operate at maximum speed. Do not operate a summer exhaust fan.
- 6 - Follow the lighting instruction to place the appliance being inspected into operation. Adjust thermostat so appliance will operate continuously.
- 7 - Use the flame of match or candle to test for spillage of flue gases at the draft hood relief opening after 5 minutes of main burner operation.
- 8 - If improper venting is observed during any of the above tests, the venting system must be corrected or sufficient combustion/make-up air must be provided. The venting system should be re-sized to approach the minimum size as determined by using the appropriate tables in appendix G in the current standards of the National Fuel Gas Code ANSI-Z223.1/NPFA 54 in the U.S.A., and the appropriate Natural Gas and Propane appliances venting sizing tables in the current standard of the CSA-B149 Natural Gas and Propane Installation Codes in Canada.
- 9 - After determining that each appliance remaining connected to the common venting system properly vents when tested as indicated in step 3, return doors, windows, exhaust fans, fireplace dampers and any other gas-burning appliance to their previous condition of use.

### **General Guidelines for Vent Terminations for Non-Direct Vent Installations.**

In Non-Direct Vent applications, combustion air is taken from indoors and the flue gases are discharged to the outdoors. The G43UF is then classified as a non-direct vent, Category IV gas furnace. In Non-Direct Vent applications, the vent termination is limited by local building codes. In the absence of local codes, refer to the current National Fuel Gas Code ANSI Z223-1/NFPA 54 in U.S.A., and current CSA-B149 Natural Gas and Propane Installation Codes in Canada for details.

Position termination end according to location given in figure 23. In addition, position termination end so it is free from any obstructions and above the level of snow accumulation (where applicable). The termination should be at least 12 inches (305mm) from any opening through which flue products could enter the building.

At vent termination, care must be taken to maintain protective coatings over building materials (prolonged exposure to exhaust condensate can destroy protective coatings). It is recommended that the exhaust outlet not be located within 6 feet (1.8m) of a condensing unit because the condensate can damage the painted coating.

*NOTE - If winter design temperature is below 32°F (0°C), exhaust piping should be insulated with 1/2" (13mm), Armaflex or equivalent when run through unheated space. Do not leave any surface area of exhaust pipe open to outside air; exterior exhaust pipe should be insulated with 1/2" (13mm) Armaflex or equivalent. In extreme cold climate*

*areas, 3/4" (19mm) Armaflex or equivalent may be necessary. Insulation on outside runs of exhaust pipe must be painted or wrapped to protect insulation from deterioration. Exhaust pipe insulation may not be necessary in some specific applications.*

*NOTE - During extremely cold temperatures, below approximately 20°F (6.7°C), units with long runs of vent pipe through unconditioned space, even when insulated, may form ice in the exhaust termination that prevents the unit from operating properly. Longer run times of at least 5 minutes will alleviate most icing problems. Also, a heating cable may be installed on exhaust piping and termination to prevent freeze-ups. Heating cable installation kit is available from Lennox. See Condensate Piping section for part numbers.*

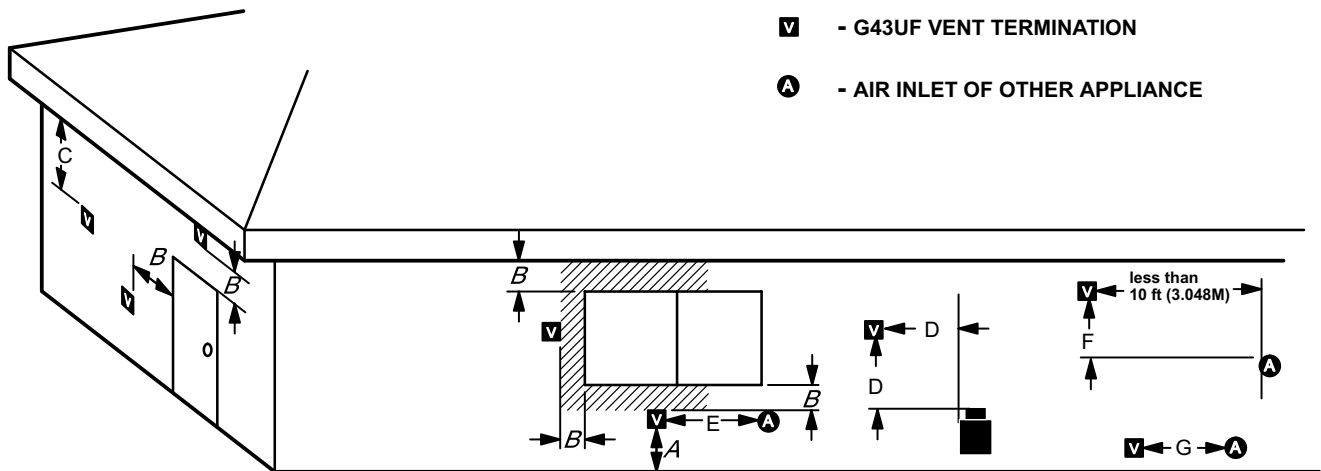
### **⚠ IMPORTANT**

**Do not use screens or perforated metal in exhaust terminations. Doing so will cause freeze-ups and may block the terminations.**

### **⚠ IMPORTANT**

**For Canadian Installations Only:  
In accordance to CSA International B149 installation codes, the minimum allowed distance between the combustion air intake inlet and the exhaust outlet of other appliances shall not be less than 12 inches (305mm).**

## VENT TERMINATION CLEARANCES FOR INSTALLATIONS IN THE USA AND CANADA\*



A - Clearance above grade - 12 in. (305mm) minimum.

B - Clearance to window or door that may be opened -  
**for vent installations in USA** - 12 in. (305mm) minimum.  
**for vent installations in Canada** - 12 in. (305mm) minimum  
for appliances  $\leq$  100,000 Btuh (30 kW);  
36 in. (0.9m) minimum for appliances  $>$  100,000 Btuh (30 kW).

C - Do not position terminations directly under roof eaves.

D - Clearance to electric meters, gas meters, regulators, and relief equipment -  
**for vent installations in USA** - 48 in (1219mm) minimum.  
**for vent installations in Canada** - see current edition of CSA B149 Code.

E - Clearance to non-mechanical air supply inlet or outlet  
**for vent installations in USA** - 48 in. (1219mm) minimum  
horizontal and below, 12 in. (305mm) minimum above.  
**for vent installations in Canada** - 12 in. (305mm) minimum  
for appliances  $\leq$  100,000 Btuh (30 kW);  
36 in. (0.9m) minimum for appliances  $>$  100,000 Btuh (30 kW).

F - Clearance to mechanical air supply inlet --  
**for vent installations in USA** - 36 in. minimum (914mm).

G - Clearance to mechanical air supply inlet --  
**for vent installations in Canada** - 72 in. (1829mm) minimum.

H - Do not point terminations into recessed areas such as window wells, stairwells or alcoves.

J - Do not position terminations directly above a walkway.

\* Note -

(I) Dimensions are from the current edition of The National Fuel Gas Code - ANSI-Z223.1/NFPA 54 for USA installations. In Canada, refer to current edition of CSA B149 installation codes. Local codes or regulations may require different clearances.

(II) In Non-Direct Vent installations, combustion air is taken from indoors and the flue gases are discharged to the outdoors.

FIGURE 23

**Details of Intake and Exhaust Piping Terminations for Direct Vent Installations**

*NOTE - In Direct Vent installations, combustion air is taken from outdoors and flue gases are discharged to outdoors.*

Intake and exhaust pipes may be routed either horizontally through an outside wall or vertically through the roof. In attic or closet installations, vertical termination through the roof is preferred. Figures 24 through 32 show typical terminations.

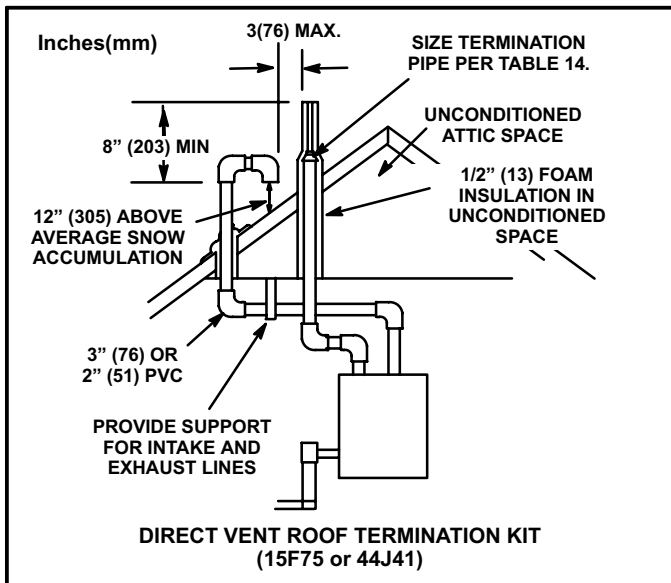
1. Exhaust and intake exits must be in same pressure zone. Do not exit one through the roof and one on the side. Also, do not exit the intake on one side and the exhaust on another side of the house or structure.
2. Intake and exhaust pipes should be placed as close together as possible at termination end (refer to illustrations). Maximum separation is 3" (76mm) on roof terminations and 6" (152mm) on side wall terminations.
3. On roof terminations, the intake piping should terminate straight down using two 90° elbows (See figure 24).
4. Exhaust piping must terminate straight out or up as shown. In rooftop applications, a reducer may be required on the exhaust piping at the point where it exits the structure to improve the velocity of exhaust away from the intake piping. See table 14.

*NOTE - Care must be taken to avoid recirculation of exhaust back into intake pipe.*

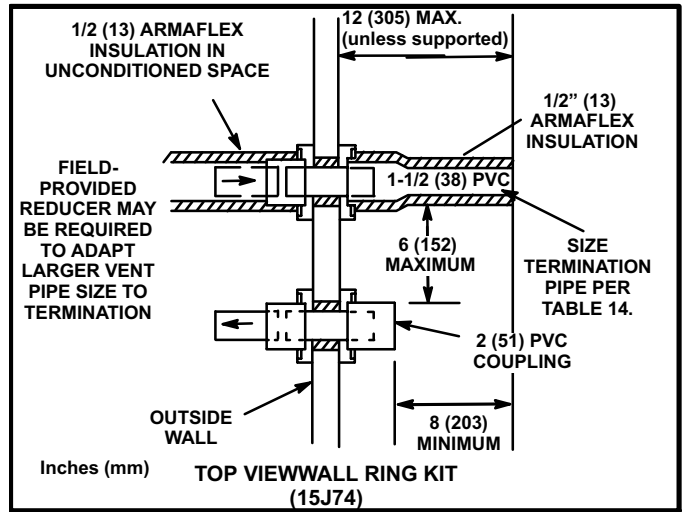
**TABLE 14  
EXHAUST PIPE TERMINATION SIZE REDUCTION**

G43UF MODEL	Exhaust Pipe Size	Termination Pipe Size
045 and 070	2", 2-1/2", 3" or 4"	1-1/2"
090	2", 2-1/2", 3" or 4"	2"
110	2", 2-1/2", 3" or 4"	2"*
135	3" or 4"	2"*

\*Approved 3" concentric termination kit terminates with 2-5/8" ID pipe.

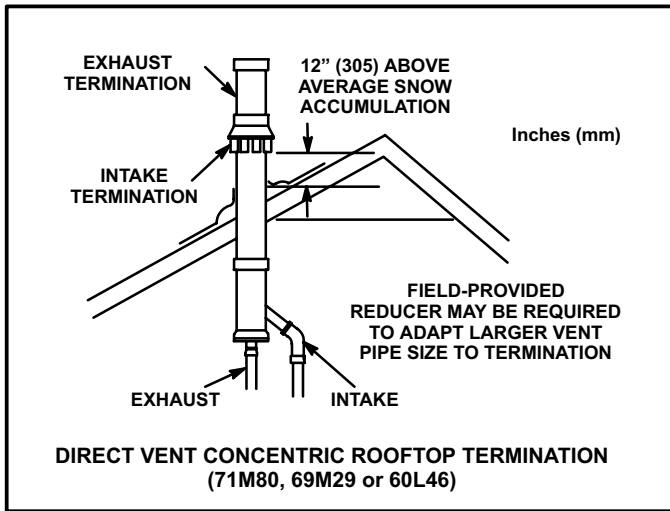


**FIGURE 24**

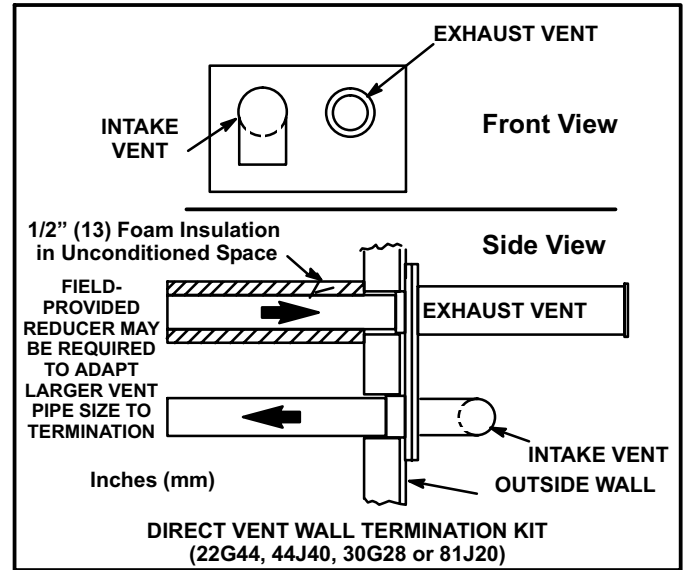


**FIGURE 25**

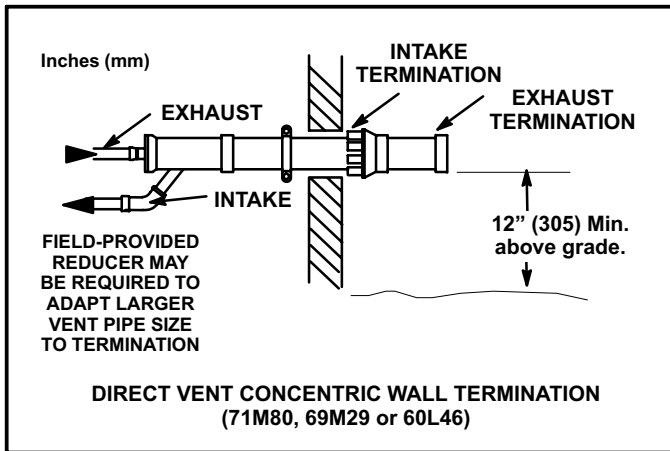
5. On field supplied terminations for side wall exits, exhaust piping should extend a maximum of 12 inches (305mm) beyond the outside wall unless supported. Intake piping should be as short as possible. See figure 25.
6. On field supplied terminations, a minimum separation distance between the end of the exhaust pipe and the end of the intake pipe is 8 inches (203mm).
7. If intake and exhaust piping must be run up a side wall to position above snow accumulation or other obstructions, piping must be supported every 3 ft. (.9m) as shown in figure 18. Refer to figure 28 for proper piping method. In addition, WTK wall termination kit must be extended for use in this application. See figure 31. When exhaust and intake piping must be run up an outside wall, the exhaust piping must be terminated with pipe sized per table 14. The intake piping may be equipped with a 90° elbow turndown. Using turndown will add 5 feet (1.5m) to the equivalent length of the pipe.
8. Based on the recommendation of the manufacturer, a multiple furnace installation may use a group of up to four termination kits WTK assembled together horizontally, as shown in figure 30.



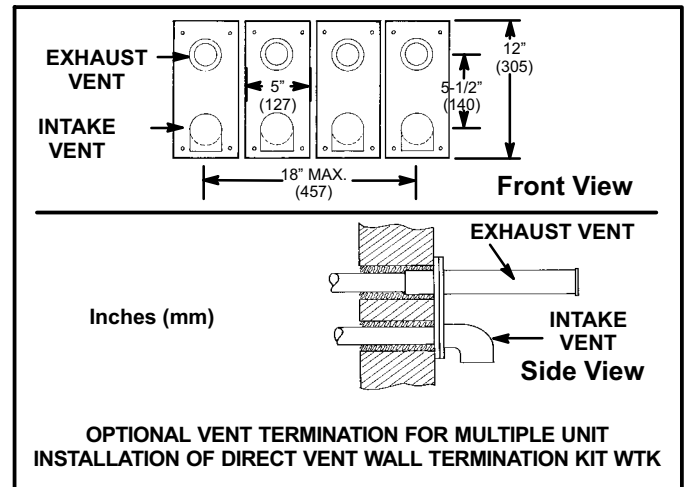
**FIGURE 26**



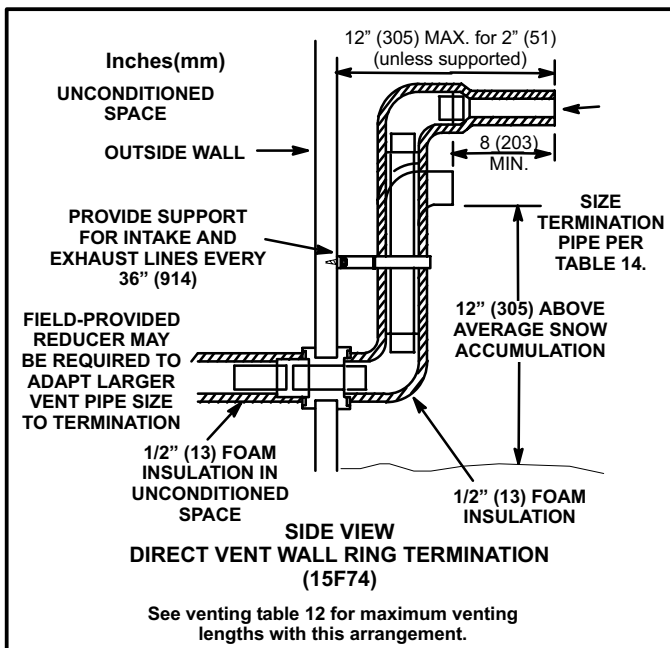
**FIGURE 29**



**FIGURE 27**



**FIGURE 30**



**FIGURE 28**





- 4 - Glue the field-provided drain line to the tee. Route the drain line to an open drain. As an alternate, clear vinyl tubing may be used to drain condensate away from the trap. Secure the vinyl tubing to the drain stubs on the trap using a hose clamp. Do not overtighten the hose clamp.

Condensate line must be sloped downward away from condensate trap to drain. If drain level is above condensate trap, condensate pump must be used. Condensate drain line should be routed within the conditioned space to avoid freezing of condensate and blockage of drain line. If this is not possible, a heat cable kit may be used on the condensate trap and line. Heating cable kit is available from Lennox in various lengths; 6 ft. (1.8m) - kit no. 26K68; 24 ft. (7.3m) - kit no. 26K69; and 50 ft. (15.2m) - kit no. 26K70.

## ⚠ CAUTION

**Do not use copper tubing or existing copper condensate lines for drain line.**

- 5 - If unit will be started immediately upon completion of installation, prime trap per procedure outlined in Unit Start-Up section.
- 6 - Glue the provided cap onto the unused condensate drain line stub.

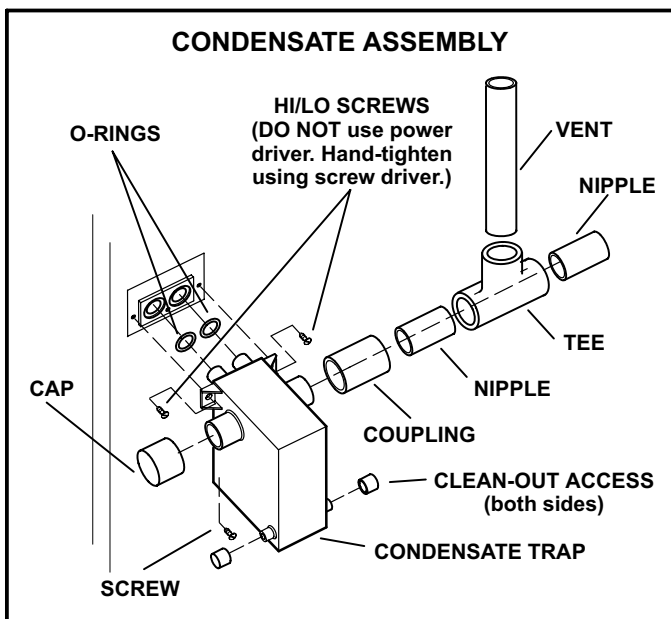


FIGURE 38

## III-START-UP

### A-Preliminary and Seasonal Checks

- 1 - Inspect electrical wiring, both field and factory installed for loose connections. Tighten as required.
- 2 - Check voltage at disconnect switch. Voltage must be within range listed on the nameplate. If not, consult the power company and have voltage condition corrected before starting unit.
- 3 - Inspect condition of condensate traps and drain assembly. Disassemble and clean seasonally.

### B-Heating Start-Up

**BEFORE LIGHTING** the unit, smell all around the furnace area for gas. Be sure to smell next to the floor because some gas is heavier than air and will settle on the floor.

The gas valve on the G43UF may be equipped with either a gas control knob or gas control lever. Use only your hand to push the lever or turn the gas control knob. Never use tools. If the lever will not move or the knob will not push in or turn by hand, replace the valve. Do not try to repair it. Force or attempted repair may result in a fire or explosion.

#### Placing the furnace into operation:

G43UF units are equipped with a SureLight ignition system. Do not attempt to manually light burners on this furnace. Each time the thermostat calls for heat, the burners will automatically light. The ignitor does not get hot when there is no call for heat on units with SureLight™ ignition system.

#### Priming Condensate Trap

The condensate trap should be primed with water prior to start-up to ensure proper condensate drainage. Either pour 10 fl. oz. (300 ml) of water into the trap, or follow these steps to prime the trap:



- 1 - Follow the lighting instructions to place the unit into operation.
- 2 - Set the thermostat to initiate a heating demand.
- 3 - Allow the burners to fire for approximately 3 minutes.
- 4 - Adjust the thermostat to deactivate the heating demand.
- 5 - Wait for the combustion air inducer to stop. Set the thermostat to initiate a heating demand and again allow the burners to fire for approximately 3 minutes.
- 6 - Adjust the thermostat to deactivate the heating demand and again wait for the combustion air inducer to stop. At this point, the trap should be primed with sufficient water to ensure proper condensate drain operation.

## ⚠ WARNING

**If you do not follow these instructions exactly, a fire or explosion may result causing property damage, personal injury or death.**

## Gas Valve Operation


### Figure 14 shows possible gas valve used

- 1 - **STOP!** Read the safety information at the beginning of this section.
- 2 - Set the thermostat to the lowest setting.
- 3 - Turn off all electrical power to the unit.
- 4 - This furnace is equipped with an ignition device which automatically lights the burners. Do **not** try to light the burners by hand.
- 5 - Remove the upper access panel.
- 6 - *White Rodgers 36G Gas Valve* - Switch gas valve lever to **OFF**.  
*Honeywell VR8205 Gas Valve* - Turn knob on gas valve clockwise  to **OFF**. Do not force.  
*Honeywell VR8205 with on / off switch* - Move switch to **OFF**.
- 7 - Wait five minutes to clear out any gas. If you then smell gas, **STOP!** Immediately call your gas supplier from a neighbor's phone. Follow the gas supplier's instructions. If you do not smell gas go to next step.
- 8 - *White Rodgers 36G Gas Valve* - Switch gas valve lever to **ON**.  
*Honeywell VR8205 Gas Valve* - Turn knob on gas valve counterclockwise  to **ON**. Do not force.  
*Honeywell VR8205 with on / off switch* - Move switch to **ON**.
- 9 - Replace the upper access panel.
- 10- Turn on all electrical power to to the unit.
- 11- Set the thermostat to desired setting.

*NOTE - When unit is initially started, steps 1 through 11 may need to be repeated to purge air from gas line.*

- 12- If the appliance will not operate, follow the instructions "Turning Off Gas to Unit" and call your service technician or gas supplier.

### Turning Off Gas to Unit

- 1 - Set the thermostat to the lowest setting.
- 2 - Turn off all electrical power to the unit if service is to be performed.
- 3 - Remove the upper access panel.
- 4 - *White Rodgers 36G Gas Valve* - Switch gas valve lever to **OFF**.  
*Honeywell VR8205 Gas Valve* - Turn knob on gas valve clockwise  to **OFF**. Do not force.  
*Honeywell VR8205 with on / off switch* - Move switch to **OFF**.

- 5 - Replace the upper access panel.

## IV-HEATING SYSTEM SERVICE CHECKS

### **IMPORTANT**

**In case emergency shutdown is required, turn off the main shut-off valve and disconnect the main power to unit. These controls should be properly labeled by the installer.**

### A-C.S.A. Certification

All units are C.S.A. design certified without modifications. Refer to the G43UF Operation and Installation Instruction Manual Information.

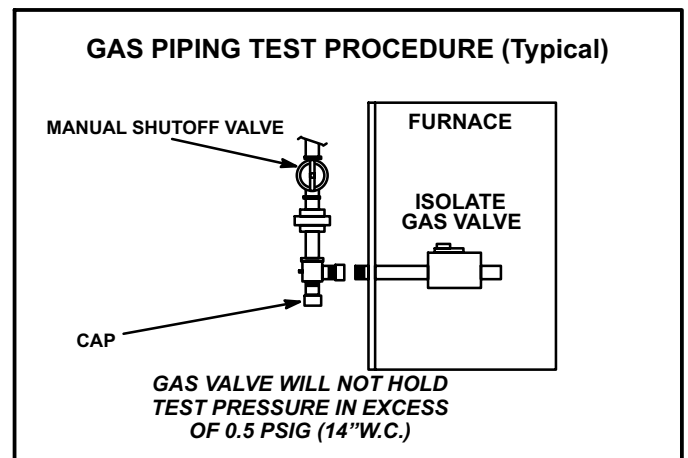
### B-Gas Piping

Gas supply piping should not allow more than 0.5"W.C. drop in pressure between gas meter and unit. Supply gas pipe must not be smaller than unit gas connection. See table 15 if gas pipe is suspect.

Compounds used on gas piping threaded joints should be resistant to action of liquefied petroleum gases.

### C-Testing Gas Piping

When pressure testing gas lines, the gas valve must be disconnected and isolated. Gas valves can be damaged if subjected to more than 0.5psig (14" W.C.). See figure 39.



**FIGURE 39**

**TABLE 15  
GAS PIPE CAPACITY - FT<sup>3</sup>/HR (kL/HR)**

Nominal Iron Pipe Size -Inches(mm)	Internal Diameter -Inches(mm)	Length of Pipe-Feet(m)									
		10 (3.048)	20 (6.096)	30 (9.144)	40 (12.192)	50 (15.240)	60 (18.288)	70 (21.336)	80 (24.384)	90 (27.432)	100 (30.480)
1/4 (6.35)	.364 (9.246)	43 (1.13)	29 (.82)	24 (.68)	20 (.57)	18 (.51)	16 (.45)	15 (.42)	14 (.40)	13 (.37)	12 (.34)
3/8 (9.53)	.493 (12.522)	95 (2.69)	65 (1.84)	52 (1.47)	45 (1.27)	40 (1.13)	36 (1.02)	33 (.73)	31 (.88)	29 (.82)	27 (.76)
1/2 (12.7)	.622 (17.799)	175 (4.96)	120 (3.40)	97 (2.75)	82 (2.32)	73 (2.07)	66 (1.87)	61 (1.73)	57 (1.61)	53 (1.50)	50 (1.42)
3/4 (19.05)	.824 (20.930)	360 (10.19)	250 (7.08)	200 (5.66)	170 (4.81)	151 (4.28)	138 (3.91)	125 (3.54)	118 (3.34)	110 (3.11)	103 (2.92)
1 (25.4)	1.049 (26.645)	680 (19.25)	465 (13.17)	375 (10.62)	320 (9.06)	285 (8.07)	260 (7.36)	240 (6.80)	220 (6.23)	205 (5.80)	195 (5.52)
1-1/4 (31.75)	1.380 (35.052)	1400 (39.64)	950 (26.90)	770 (21.80)	660 (18.69)	580 (16.42)	530 (15.01)	490 (13.87)	460 (13.03)	430 (12.18)	400 (11.33)
1-1/2 (38.1)	1.610 (40.894)	2100 (59.46)	460 (41.34)	1180 (33.41)	990 (28.03)	900 (25.48)	810 (22.94)	750 (21.24)	690 (19.54)	650 (18.41)	620 (17.56)
2 (50.8)	2.067 (52.502)	3950 (111.85)	2750 (77.87)	2200 (62.30)	1900 (53.80)	1680 (47.57)	1520 (43.04)	1400 (39.64)	1300 (36.81)	1220 (34.55)	1150 (32.56)
2-1/2 (63.5)	2.469 (67.713)	6300 (178.39)	4350 (123.17)	3520 (99.67)	3000 (84.95)	2650 (75.04)	2400 (67.96)	2250 (63.71)	2050 (58.05)	1950 (55.22)	1850 (52.38)
3 (76.2)	3.068 (77.927)	11000 (311.48)	7700 (218.03)	6250 (176.98)	5300 (150.07)	4750 (134.50)	4300 (121.76)	3900 (110.43)	3700 (104.77)	3450 (97.69)	3250 (92.03)
4 (101.6)	4.026 (102.260)	23000 (651.27)	15800 (447.39)	12800 (362.44)	10900 (308.64)	9700 (274.67)	8800 (249.18)	8100 (229.36)	7500 (212.37)	7200 (203.88)	6700 (189.72)

NOTE-Capacity given in cubic feet of gas per hour (kilo liters of gas per hour) and based on 0.60 specific gravity gas.

## **⚠ IMPORTANT**

The furnace must be isolated from the gas supply piping system by closing its individual manual shut-off valve during any pressure testing of the gas supply piping system at test pressures equal to or less than 1/2 psig (3.45 kPa).

The furnace and its individual shut-off valve must be disconnected from the gas supply piping system during any pressure testing of the system at test pressures greater than 1/2 psig (3.45 kPa). See figure 39.

When checking piping connections for gas leaks, use preferred means. Kitchen detergents can cause harmful corrosion on various metals used in gas piping. Use of a specialty Gas Leak Detector is strongly recommended. It is available through Lennox under part number 31B2001. See Corp. 8411-L10, for further details.

## **⚠ WARNING**

Do not use matches, candles, flame or any other source of ignition to check for gas leaks.

### **D-Testing Gas Supply Pressure**

When testing supply gas pressure, use the 1/8" N.P.T. plugged tap or pressure post located on the gas valve to

facilitate test gauge connection. See figure 14. Check gas line pressure with unit firing at maximum rate. Low pressure may result in erratic operation or underfire. High pressure can result in permanent damage to gas valve or overfire. For natural gas units, operating pressure at unit gas connection must be between 4.5" W.C. and 13.0" W.C. For L.P. gas units, operating pressure at unit gas connection must be between 10.5" and 13.0" W.C.

On multiple unit installations, each unit should be checked separately, with and without units operating. Supply pressure must fall within range listed in previous paragraph.

### **E-Check Manifold Pressure**

Manifold pressure is the manifold pressure measured when the gas valve regulator is operating at factory preset level *sensing atmospheric pressure*.

## **⚠ IMPORTANT**

The White Rodgers 36G gas valve (figure 14) is equipped with pressure posts for measuring supply and manifold pressures. The posts provide built-in hose connections and have an integral 3/32" Allen-head screw. Rotate the screw counterclockwise one full turn to permit pressure measurement. Reseat the screw (rotate one full turn clockwise) after measurements have been taken to prevent gas leakage.

After line pressure has been checked and adjusted, check manifold pressure. Move pressure gauge to outlet pressure tap located on unit gas valve (GV1).

Checks of manifold pressure are made as verification of proper regulator adjustment.

Manifold operating pressure for the G43UF can be measured at any time the gas valve is open and is supplying gas to the unit.

**TABLE 16**

GAS VALVE MANIFOLD PRESSURE W.C.	
Natural	3.5 ± 0.3
L.P.	10.0 ± 0.7

## ⚠ IMPORTANT

**For safety, connect a shut-off valve between the manometer and the gas tap to permit shut off of gas pressure to the manometer.**

### Manifold Pressure Measurement and Adjustment

- 1 - Connect test gauge to outlet tap on gas valve.
- 2 - Disconnect pressure sensing hose from the gas valve. Plug end of hose using tape or equivalent. Leave hose barb on gas valve open to atmosphere.
- 3 - Start unit and allow 5 minutes for unit to reach steady state.
- 4 - While waiting for the unit to stabilize, notice the flame. Flame should be stable and should not lift from burner. Natural gas should burn blue. L.P. gas should burn mostly blue with some orange streaks.
- 5 - After allowing unit to stabilize for 5 minutes, adjust the manifold pressure on the gas valve if necessary (see table 16).
- 6 - When test is complete, reconnect sensing hose to gas valve barb.

*NOTE-Shut unit off and remove manometer as soon as an accurate reading has been obtained. Take care to replace pressure tap plug.*

### F- Proper Gas Flow (Approximate)

Furnace should operate at least 5 minutes before checking gas flow. Determine time in seconds for **two** revolutions of gas through the meter. (Two revolutions assures a more accurate time.) **Divide by two** and compare to time in table 17 below. Adjust manifold pressure on gas valve to match time needed.

*NOTE- To obtain accurate reading, shut off all other gas appliances connected to meter.*

**TABLE 17**

G43UF Unit	GAS METER CLOCKING CHART			
	Seconds for One Revolution			
	Natural		LP	
	1 cu ft Dial	2 cu ft Dial	1 cu ft Dial	2 cu ft DIAL
-045	80	160	200	400
-070	51	102	129	258
-090	40	80	100	200
-110	33	66	82	164
-135	27	53	67	134
Natural-1000 btu/cu ft		LP-2500 btu/cu ft		

### G- Proper Combustion

Furnace should operate at least 15 minutes with correct manifold pressure and gas flow rate before checking combustions. Take sample beyond the flue outlet and compare to table 18. The maximum carbon monoxide reading should not exceed 100 ppm.

**TABLE 18**

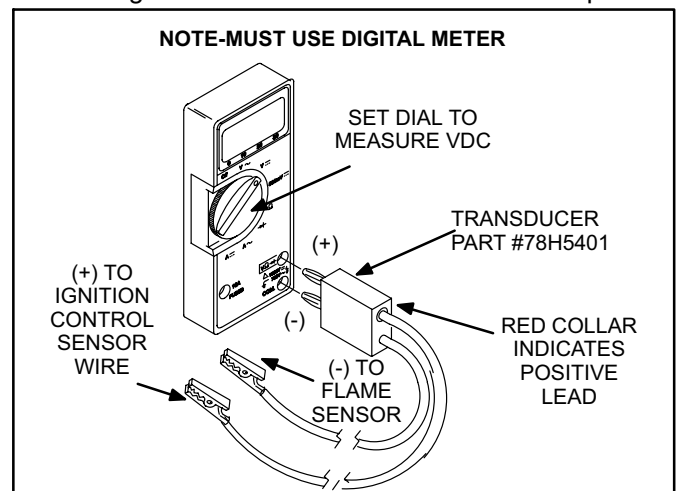
Unit Btuh	CO <sub>2</sub> % For Nat	CO <sub>2</sub> % For L.P
-045	6.3 - 7.3	7.4 - 8.4
-070	6.5 - 7.5	7.6 - 8.6
-090	7.0 - 8.0	8.2 - 9.2
-110		
-135		

### H-Flame Signal

A transducer (Part #78H5401 available from Lennox Repair Parts) is required to measure flame signal if meter used will not read a low micro amp signal. See figure 40. The transducer converts microamps to volts on a 1:1 conversion. Flame signal for the G43UF-2 and later units should read a minimum 1.5 microamps with a lockout signal of 0.5 ( G43UF-1 units should read a minimum 0.18 microamps with a lockout signal of 0.15 microamps). A digital readout meter must be used. The transducer plugs into most meters.

#### To Measure Flame Signal:

- 1 - Set the volt meter to the DC voltage scale. Insert transducer into the VDC and common inputs. Observe correct polarities. Failure to do so results in negative (-) values.
- 2 - Turn off supply voltage to control.
- 3 - Disconnect ignition control flame sensor wire from the flame sensor.
- 4 - Connect (-) lead of the transducer to flame sensor.
- 5 - Connect (+) lead of transducer to the ignition control sensor wire.
- 6 - Turn supply voltage on and close thermostat contacts to cycle system.
- 7 - When main burners are in operation for two minutes, take reading. Remember 1 DC volt = 1 DC microamp.



**FIGURE 40**

## I-High Altitude

*NOTE - In Canada, certification for installations at elevations over 4500 feet (1372 m) is the jurisdiction of local authorities.*

The manifold pressure may require adjustment to ensure proper operation at higher altitudes. Refer to table 19 for proper manifold pressure settings at varying altitudes. Table 20 lists required pressure switch changes and conversion kits at varying altitudes.

The combustion air pressure switches are factory-set and require no adjustment.

**TABLE 19**  
**Manifold Pressure (Outlet) inches w.c.**

Fuel	Model Input Sizes	Altitude (feet)				
		0-4500	4501-5500	5501-6500	6501-7500	7501-10,000
Nat. Gas	045, 070, 090, 110	3.5	3.5	3.5	3.5	3.5*
Nat. Gas	135-1, -3	3.5	3.3	3.2	3.1	3.5*
	135-4 and later	3.5	3.5	3.5	3.5	3.5*
L.P. Gas	All sizes	10.0**	10.0**	10.0**	10.0**	10.0**

\* Conversion kit required for applications at altitudes above 7501 ft. above sea level.

\*\* Conversion kit required for all applications at all altitudes.

**TABLE 20**  
**Conversion Kit and Pressure Switch Requirements at Varying Altitudes**

Model Input Size	Gas	Altitude					
		0 - 4500 ft. (0 - 1372 m)		4,501 - 7500 ft. (1373 - 2286 m)		7501-10,000 ft. (2287 - 3048 m)	
		Required Conversion Kit	Pressure Switch	Required Conversion Kit	Pressure Switch	Required Conversion Kit	Pressure Switch
045/070-1 to -6	Nat.	N/A	No Change	N/A	No Change	59M16	56M06
	LPG	83M74	No Change	83M74	No Change	83M75	56M06
045-7 and later	Nat.	N/A	No Change	N/A	No Change	59M17	95M22
	LPG	83M74	No Change	83M74	No Change	83M75	95M22
070-7 and later	Nat.	N/A	No Change	N/A	56M05	59M17	56M06
	LPG	83M74	No Change	83M74	56M05	83M75	56M06
090/110-1 to -6	Nat.	N/A	No Change	N/A	75M20	59M16	56M07
	LPG	83M74	No Change	83M74	75M20	83M75	56M07
090/110-7 and later	Nat.	N/A	No Change	N/A	75M20	59M17	56M07
	LPG	83M74	No Change	83M74	75M20	83M75	56M07
135-1, -3	Nat.	N/A	No Change	N/A	56M04	47M82	60M35
	LPG	83M74	No Change	83M74	56M04	83M75	60M35
135-4 and later	Nat.	N/A	No Change	N/A	56M04	59M17	60M35
	LPG	83M74	No Change	83M74	56M04	83M75	60M35

Pressure switch is factory set. No adjustment necessary. All models use the factory installed pressure switch from 0-4500 feet (0-1370 m).

## V-TYPICAL OPERATING CHARACTERISTICS

### A-Blower Operation and Adjustment

*NOTE- The following is a generalized procedure and does not apply to all thermostat controls.*

- 1 - Blower operation is dependent on thermostat control system.
- 2 - Generally, blower operation is set at thermostat sub-base fan switch. With fan switch in ON position, blower operates continuously. With fan switch in AUTO position, blower cycles with demand or runs continuously while heating or cooling circuit cycles.
- 3 - In all cases, blower and entire unit will be off when the system switch is in OFF position.

### B-Temperature Rise

Temperature rise for G43UF units depends on unit input,

blower speed, blower horsepower, filter resistance and installed duct system resistance. The blower speed must be set for unit operation within the range of "TEMPERATURE RISE °F" listed on the unit rating plate.

#### To Measure Temperature Rise:

- 1 - Place plenum thermometers in the supply and return air plenums. Locate supply air thermometer in the first horizontal run of the plenum where it will not pick up radiant heat from the heat exchanger.
- 2 - Set thermostat to highest setting.
- 3 - After plenum thermometers have reached their highest and steadiest readings, subtract the two readings. The difference should be in the range listed on the unit rating plate. If the temperature is too low, decrease blower speed. If temperature is too high, first check the firing rate. Provided the firing rate is acceptable, increase blower speed to reduce temperature. To change blower speed taps see the Blower Speed Taps section in this manual.

## C-External Static Pressure

- 1 - Measure tap locations as shown in figure 41.
- 2 - Punch a 1/4" diameter hole in supply and return air plenums. Insert manometer hose flush with inside edge of hole or insulation. Seal around the hose with perma-gum. Connect the zero end of the manometer to the discharge (supply) side of the system. On ducted systems, connect the other end of manometer to the return duct as above. For systems with non-ducted returns, leave the other end of the manometer open to the atmosphere.
- 3 - With only the blower motor running and the evaporator coil dry, observe the manometer reading. Adjust blower motor speed to deliver the air desired according to the job requirements.
- 4 - Static pressure must not exceed 0.5" W.C.
- 5 - Seal around the hole when the check is complete.

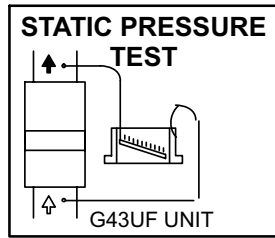


FIGURE 41

## D-Blower Speed Taps Led Motors

Blower speed tap changes are made on the SureLight control board. See figures 6 and 8. On G43UF-1 units, the heating tap is connected to the "HEAT-H" terminal and the cooling tap is connected to the "COOL-H" terminal. On G43UF-2 and later units, the heating tap is connected to the "HEAT" terminal and the cooling tap is connected to the "COOL" terminal. On all units the continuous blower tap is the same as the heating tap and unused taps must be secured on two dummy terminals labeled "PARK".

To change existing heat tap, turn off power then switch out speed tap with tap connected to "PARK". See unit diagram for blower motor tap colors for each speed.

*NOTE - Do not use red (low speed) motor lead for heating. Leave on PARK terminal for 24B-070, 36C-090 and 48C-110 units.*

*NOTE - Operation of this furnace in heating mode (indoor blower operating at selected heating speed) with an external static pressure which exceeds 0.5 inches w.c. may result in erratic limit operation.*

## G43UF BLOWER REMOVAL

### To Remove Blower:

Turn off line voltage power.

- 1 Disconnect thermostat wiring connections.
- 2 Disconnect blower leads from control board and secondary limit wires.
- 3 Loosen screws (2) and remove control box from unit. Holes are slotted so screws do not need to be removed.
- 4 Remove screws (2) and remove blower from unit.

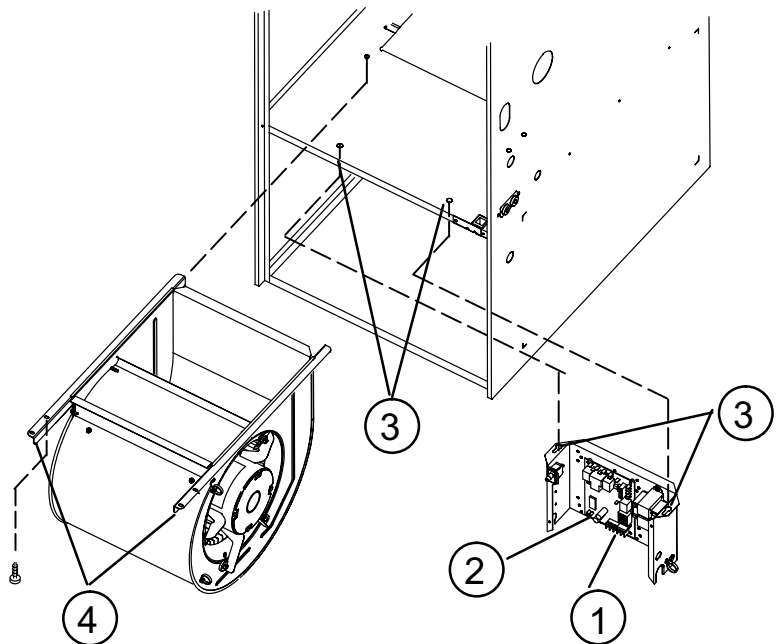


FIGURE 42

## VI-MAINTENANCE

### **⚠ WARNING**

**ELECTRICAL SHOCK, FIRE,  
OR EXPLOSION HAZARD.**

Failure to follow safety warnings exactly could result in dangerous operation, serious injury, death or property damage.

Improper servicing could result in dangerous operation, serious injury, death, or property damage.

Before servicing, disconnect all electrical power to furnace.

When servicing controls, label all wires prior to disconnecting. Take care to reconnect wires correctly. Verify proper operation after servicing.

At the beginning of each heating season, system should be checked as follows by a qualified service technician:

#### Blower

Check the blower wheel for debris and clean if necessary. The blower motors are prelubricated for extended bearing life. No further lubrication is needed.

### **⚠ WARNING**

The blower access panel must be securely in place when the blower and burners are operating. Gas fumes, which could contain carbon monoxide, can be drawn into living space resulting in personal injury or death.

#### Filters

Filters should be inspected monthly. Clean or replace the filters when necessary to ensure proper furnace operation. Replacement filters must be rated for high velocity airflow. Table 21 lists recommended filter sizes.

**TABLE 21**

Furnace Cabinet Size	Filter Size	
	Side Return	Bottom Return
17-1/2"	16 X 25 X 1 (1)	16 X 25 X 1 (1)
21"	16 X 25 X 1 (1)	20 X 25 X 1 (1)
24-1/2"	16 X 25 X 1 (2)	24 X 25 X 1 (1)

#### Exhaust and air intake pipes

Check the exhaust and air intake pipes and all connections for tightness and to make sure there is no blockage.

#### Electrical

- 1 - Check all wiring for loose connections.
- 2 - Check for the correct voltage at the furnace (furnace operating).
- 3 - Check amp-draw on the blower motor.  
Motor Nameplate \_\_\_\_\_ Actual \_\_\_\_\_

#### Winterizing and Condensate Trap Care

- 1 - Turn off power to the unit.
- 2 - Have a shallow pan ready to empty condensate water.
- 3 - Remove the drain plug from the condensate trap and empty water. Inspect the trap then reinstall the drain plug.

#### Cleaning Heat Exchanger

### **⚠ IMPORTANT**

**Safety glasses and surgical mask should be worn when cleaning heat exchanger and or burner assembly.**

If cleaning the heat exchanger becomes necessary, follow the below procedures and refer to figure 1 when disassembling unit. Use papers or protective covering in front of furnace while removing heat exchanger assembly.

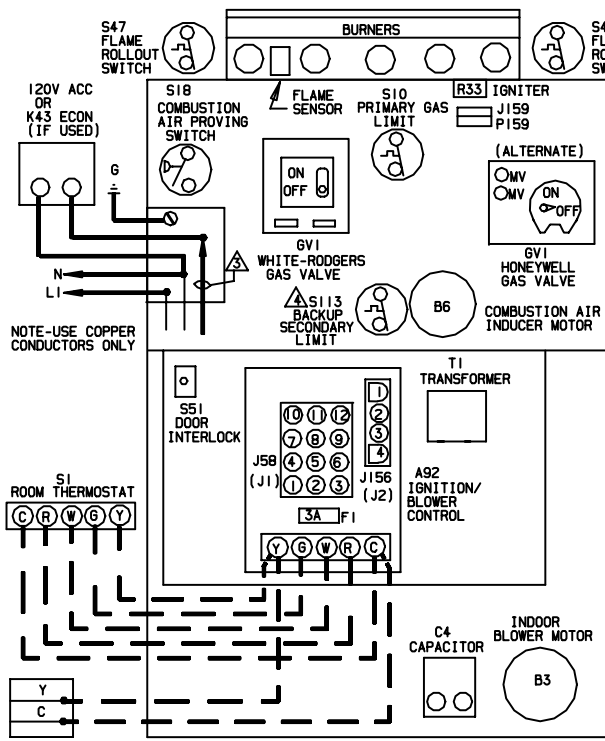
- 1 - Turn off electrical and gas supplies to the furnace.
- 2 - Remove the upper and lower furnace access panels.
- 3 - Mark all gas valve wires and disconnect them from valve.
- 4 - Remove gas supply line connected to gas valve. Remove gas valve/manifold assembly.
- 5 - Remove sensor wire from sensor. Disconnect 2-pin plug from the ignitor.
- 6 - Disconnect wires from flame roll-out switch.
- 7 - Remove burner box front cover and remove burner box screws at the vestibule panel. Set burner box assembly aside.

*NOTE - If necessary, clean burners at this time. Follow procedures outlined in Burner Cleaning section.*

- 8 - Loosen three clamps and remove flexible exhaust tee.
- 9 - Remove 3/8 inch rubber cap from condensate drain plug and drain. Replace cap after draining.
- 10 - Disconnect condensate drain line from the condensate trap. Remove condensate trap (it may be necessary to cut drain pipe). Remove screws that secure both condensate collars to either side of the furnace and remove collars. Remove drain tubes from cold end header collector box.
- 11 - Disconnect condensate drain tubing from flue collar. Remove screws that secure both flue collars into place. Remove flue collars. It may be necessary to cut the exiting exhaust pipe for removal of the fittings.
- 12 - Disconnect the 2-pin plug from the combustion air inducer. Disconnect the two wires to the secondary limit, if applicable. Remove four screws which secure combustion air inducer to collector box. Remove combustion air inducer assembly. Remove ground wire from vest panel.
- 13 - Mark and disconnect combustion air pressure tubing from cold end header collector box.
- 14 - Mark and remove wires from pressure switch. Remove pressure switch. Keep tubing attached to pressure switch.
- 15 - Remove electrical junction box from the side of the furnace.

- 16 - Mark and disconnect any remaining wiring to heating compartment components. Disengage strain relief bushing and pull wiring and bushing through the hole in the blower deck.
  - 17 - Remove the primary limit from the vestibule panel.
  - 18 - Remove two screws from the front cabinet flange at the blower deck. Spread cabinet sides slightly to allow clearance for removal of heat exchanger.
  - 19 - Remove screws along vestibule sides and bottom which secure vestibule panel and heat exchanger assembly to cabinet. Remove two screws from blower rail which secure bottom heat exchanger flange. Remove heat exchanger from furnace cabinet. **Do not remove turbulators or baffles from secondary heat exchanger.**
  - 20 - Back wash heat exchanger with soapy water solution or steam. **If steam is used it must be below 275°F (135°C) .**
  - 21 - Thoroughly rinse and drain the heat exchanger. Soap solutions can be corrosive. Take care to rinse entire assembly.
  - 22 - Reinstall heat exchanger into cabinet making sure that the clamshells of the heat exchanger assembly are resting on the support located at the rear of the cabinet. Remove the indoor blower to view this area through the blower opening.
  - 23 - Re-secure the supporting screws along the vestibule sides and bottom to the cabinet.
  - 24 - Reinstall cabinet screws on front flange at blower deck.
  - 25 - Reinstall the primary limit on the vestibule panel.
  - 26 - Route heating component wiring through hole in blower deck and reinsert strain relief bushing.
  - 27 - Reinstall pressure switch and reconnect pressure switch wiring.
  - 28 - Carefully connect combustion air prove switch housing from prove switch to proper stubs on cold end header box.
  - 29 - Reinstall condensate collars on each side of the furnace. Reconnect drain tubing to collector box.
  - 30 - Reinstall condensate trap on same side as exhaust pipe. Reconnect condensate drain line to the condensate trap.
  - 31 - Reinstall electrical junction box.
  - 32 - Reinstall the combustion air inducer. Reconnect the 2-pin plug to the wire harness. Reconnect the two wires to the secondary limit, if applicable.
  - 33 - Use securing screws to reinstall flue collars to either side of the furnace. Reconnect exhaust piping and exhaust drain tubing.
  - 34 - Replace flexible exhaust tee on combustion air inducer and flue collars. Secure using three existing hose clamps.
  - 35 - Reinstall burner box assembly in vestibule area.
  - 36 - Reconnect flame roll-out switch wires.
  - 37 - Reconnect sensor wire and reconnect 2-pin plug from ignitor.
  - 38 - Secure burner box assembly to vestibule panel using four existing screws. **Make sure burners line up in center of burner ports.**
  - 39 - Reinstall gas valve manifold assembly. Reconnect gas supply line to gas valve.
  - 40 - Reinstall burner box cover.
  - 41 - Reconnect wires to gas valve.
  - 42 - Replace the blower compartment access panel.
  - 43 - Refer to instruction on verifying gas and electrical connections when re-establishing supplies.
  - 44 - Follow lighting instructions to light and operate furnace for 5 minutes to ensure that heat exchanger is clean and dry and that furnace is operating properly.
  - 45 - Replace heating compartment access panel.
- Cleaning the Burner Assembly**
- 1 - Turn off electrical and gas power supplies to furnace. Remove upper and lower furnace access panels.
  - 2 - Mark all gas valve wires and disconnect them from the valve.
  - 3 - Disconnect the gas supply line from the gas valve. Remove gas valve/manifold assembly.
  - 4 - Mark and disconnect sensor wire from the sensor. Disconnect 2-pin plug from the ignitor at the burner box.
  - 5 - Remove burner box front cover and remove screws which secure burner box assembly to vestibule panel. Remove burner box from the unit.
  - 6 - Use the soft brush attachment on a vacuum cleaner to gently clean the face of the burners. Visually inspect the inside of the burners and crossovers for any blockage caused by foreign matter. Remove any blockage.
  - 7 - Reconnect the sensor wire and reconnect the 2-pin plug to the ignitor wiring harness.
  - 8 - Reinstall the burner box assembly using the existing four screws. Make sure that the burners line up in the center of the burner ports.
  - 9 - Reinstall the gas valve manifold assembly. Reconnect the gas supply line to the gas valve. Reinstall burner box cover.
  - 10 - Reconnect the gas valve wires to the gas valve.
  - 11 - Replace the blower compartment access panel.
  - 12 - Refer to instruction on verifying gas and electrical connections when re-establishing supplies.
  - 13 - Follow lighting instructions to light and operate furnace for 5 minutes to ensure that heat exchanger is clean and dry and that furnace is operating properly.
  - 14 - Replace heating compartment access panel.

# VII-WIRING DIAGRAM AND SEQUENCE OF OPERATION



BLOWER SPEED CHART				
UNIT	FACTORY CONNECTED	SPEED TAPS	PARK	MOTOR SPEEDS AVAIL.
24B-045	YELLOW	RED	----	3
24B-070	YELLOW	RED	----	3
36B-070	YELLOW	RED	BROWN	4
36C-090	BROWN	RED	YELLOW	4
48C-090	YELLOW	RED	BROWN	4
48C-110	YELLOW	RED	BROWN	4
60C-110	YELLOW	RED	BROWN	4
60D-135	YELLOW	RED	BROWN	4

BLOWER SPEED SELECTION			
HI	LO	---	---
SPEED	BLACK	YELLOW	RED
TAPS	BLACK	BROWN	YELLOW RED

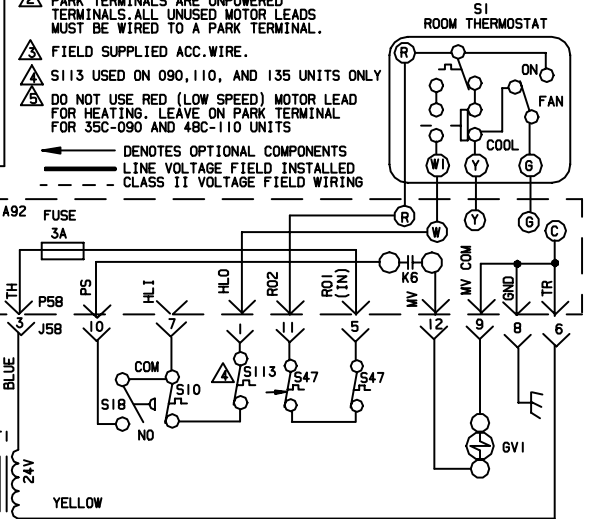
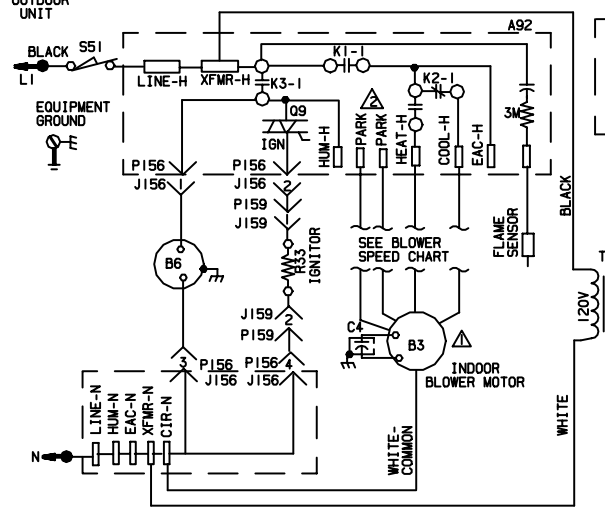
THERMOSTAT HEAT ANTICIPATION SETTINGS	
.65 AMP	HONEYWELL VALVE
.50 AMP	WHITE-RODGERS VALVE

JACKPLUG CHART	
J, P58	JACK/PLUG-BURNER CONTROL
J, P155	JACK/PLUG-INDUCER/IGNITER
J, P159	JACK/PLUG-IGNITER

WARNING- ELECTRIC SHOCK HAZARD, CAN CAUSE INJURY OR DEATH. UNIT MUST BE GROUNDED IN ACCORDANCE WITH NATIONAL AND LOCAL CODES.

NOTE- IF ANY WIRE IN THIS APPLIANCE IS REPLACED, IT MUST BE REPLACED WITH WIRE OF LIKE SIZE, RATING, INSULATION THICKNESS AND TERMINATION.

- IMPORTANT- TO PREVENT MOTOR BURNOUT, NEVER CONNECT MORE THAN ONE LEAD TO ANY ONE CONNECTION.
- PARK TERMINALS ARE UNPOWERED TERMINALS. ALL UNUSED MOTOR LEADS MUST BE WIRED TO A PARK TERMINAL.
- FIELD SUPPLIED ACC. WIRE.
- S113 USED ON 090, 110, AND 135 UNITS ONLY
- DO NOT USE RED (LOW SPEED) MOTOR LEAD FOR HEATING. LEAVE ON PARK TERMINAL FOR 35C-090 AND 48C-110 UNITS
- DENOTES OPTIONAL COMPONENTS
- LINE VOLTAGE FIELD INSTALLED
- - - CLASS II VOLTAGE FIELD WIRING



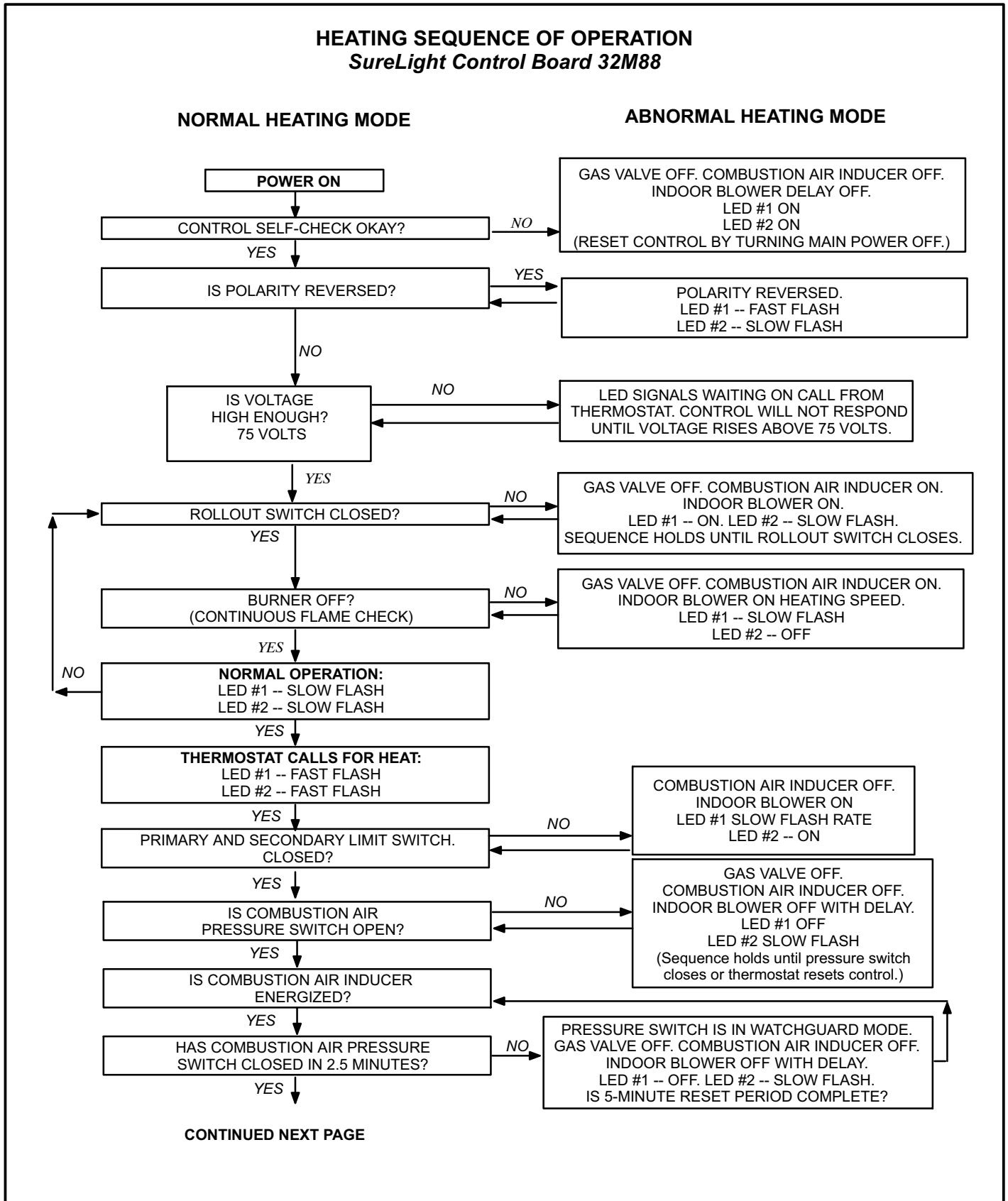
LENNOX® HEATING UNITS-GAS	
643UF-24B-045-01,02	643UF-48C-090-01,02
643UF-24B-070-01,02	643UF-48C-110-01,02
643UF-36B-070-01,02	643UF-60C-110-01,02
643UF-36C-090-01,02	643UF-60D-135-01,02
Supersedes	
0104	
New Form No.	
534, 589W	

©2004 Lennox Industries Inc. Litho U.S.A.

- When there is a call for heat, W1 of the thermostat energizes W of the furnace control with 24VAC.
- S10 primary limit switch and S47 rollout switch are closed. Call for heat can continue.
- The integrated control (A92) energizes combustion air inducer B6. Combustion air inducer runs until S18 combustion air prove switch closes (switch must close within 2-1/2 minutes or control goes into 5 minute Watchguard Pressure Switch delay). Once S18 closes, a 15-second pre-purge follows.
- The integrated control (A92) energizes ignitor. A 20-second warm-up period begins.
- Gas valve opens for a 4-second trial for ignition
- Flame is sensed, gas valve remains open for the heat call.
- After 45-second delay, the integrated control (A92) energizes indoor blower B3.
- When heat demand is satisfied, W1 of the indoor thermostat de-energizes W of the integrated control which de-energizes the gas valve. Combustion air inducer B6 continues a 5-second post-purge period, and indoor blower B3 completes a selected OFF time delay.

# G43UF Units with SureLight Control Board 32M88

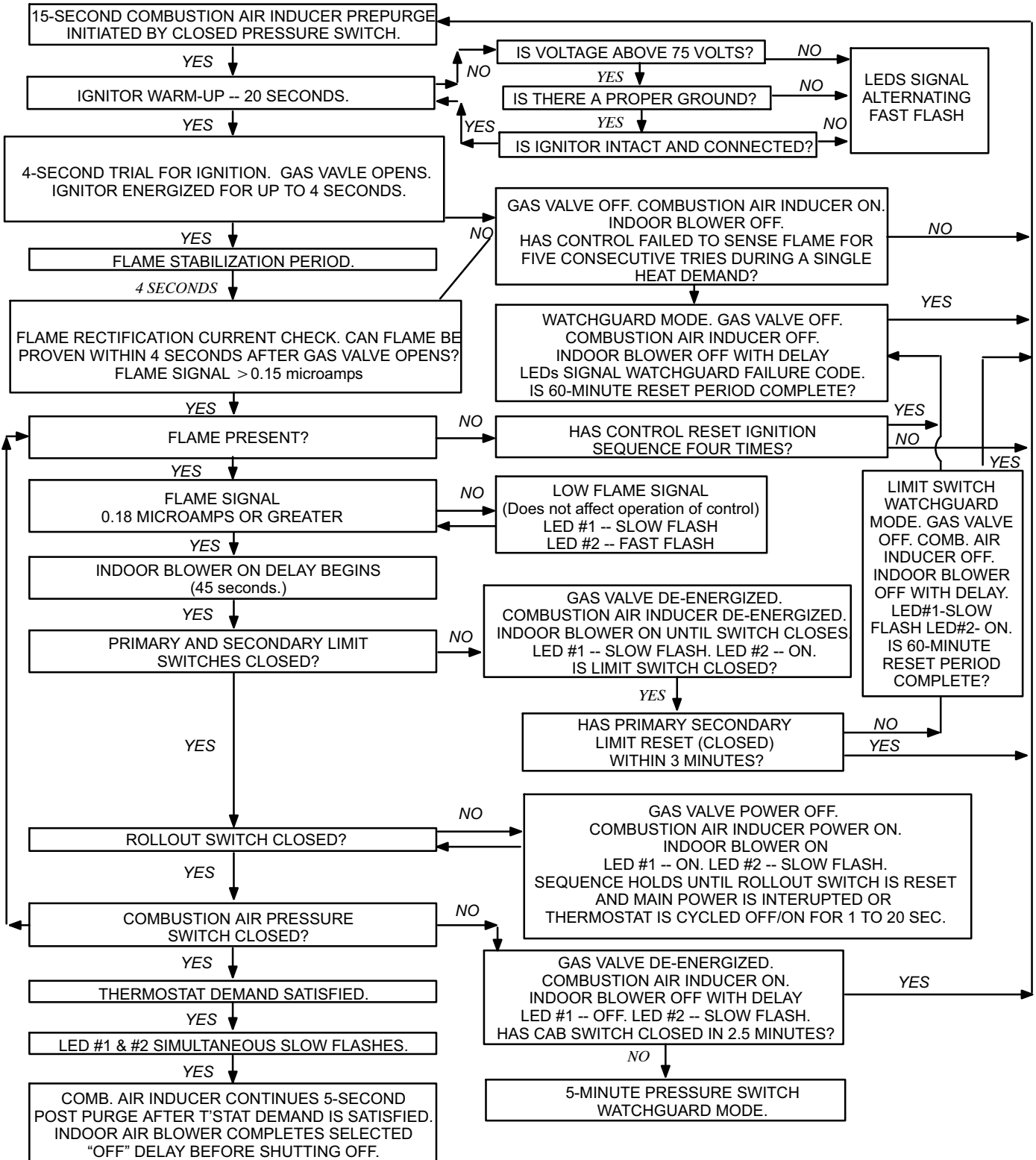
LED#1 = DS1 LED#2 = DS2 See Figure 6



## HEATING SEQUENCE CONTINUED SureLight Control Board 32M88

### NORMAL HEATING MODE

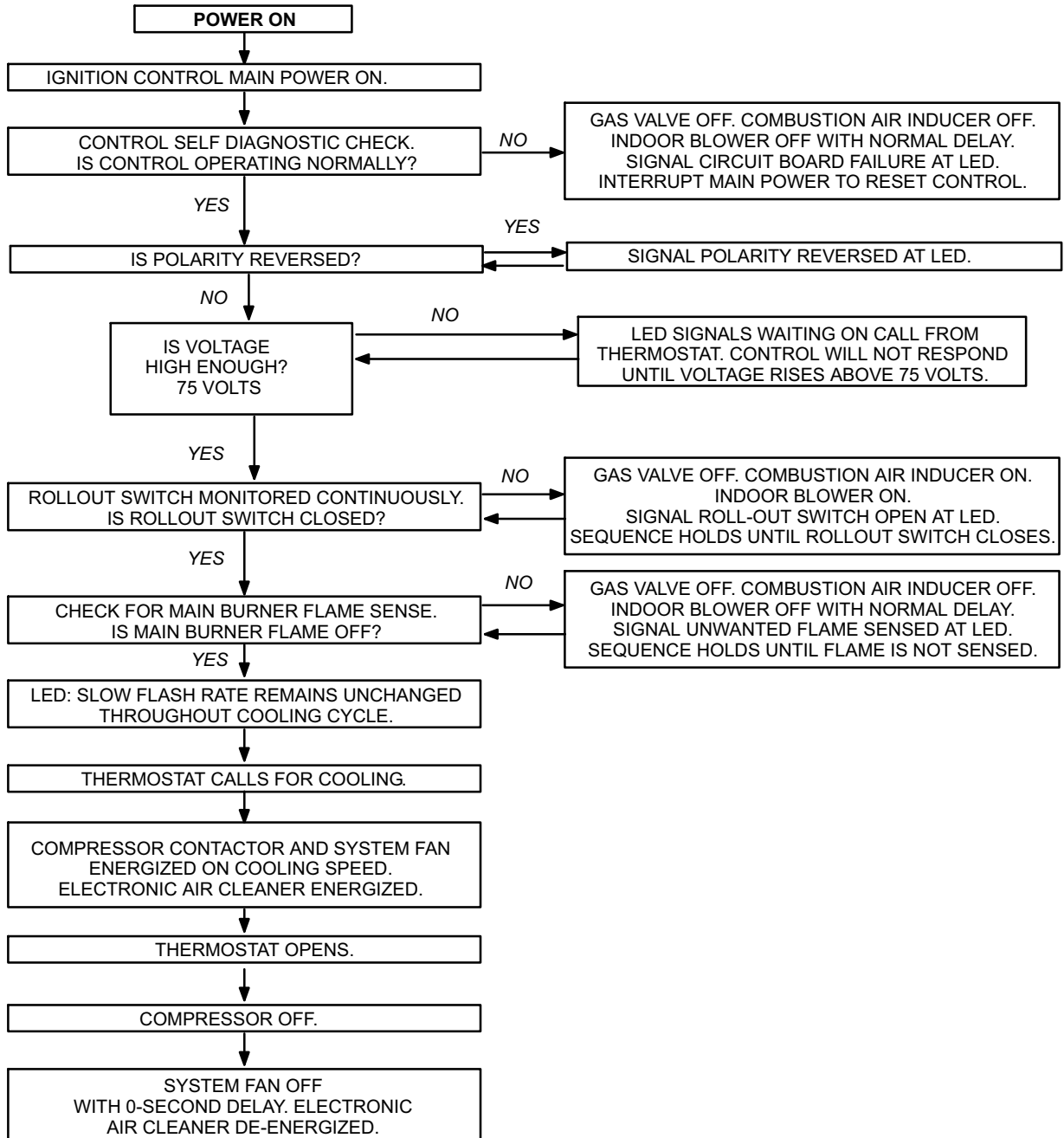
### ABNORMAL HEATING MODE



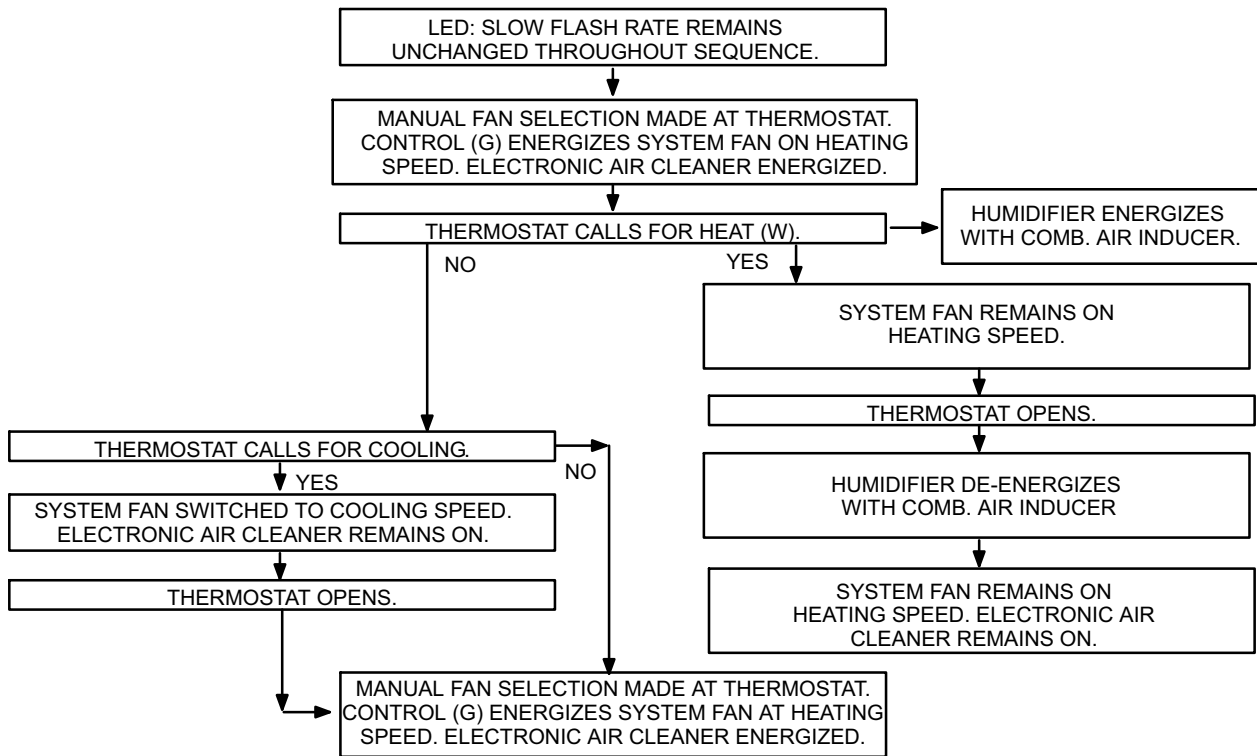
## COOLING SEQUENCE OF OPERATION SureLight Control Board 32M88

### NORMAL COOLING MODE

### ABNORMAL COOLING MODE



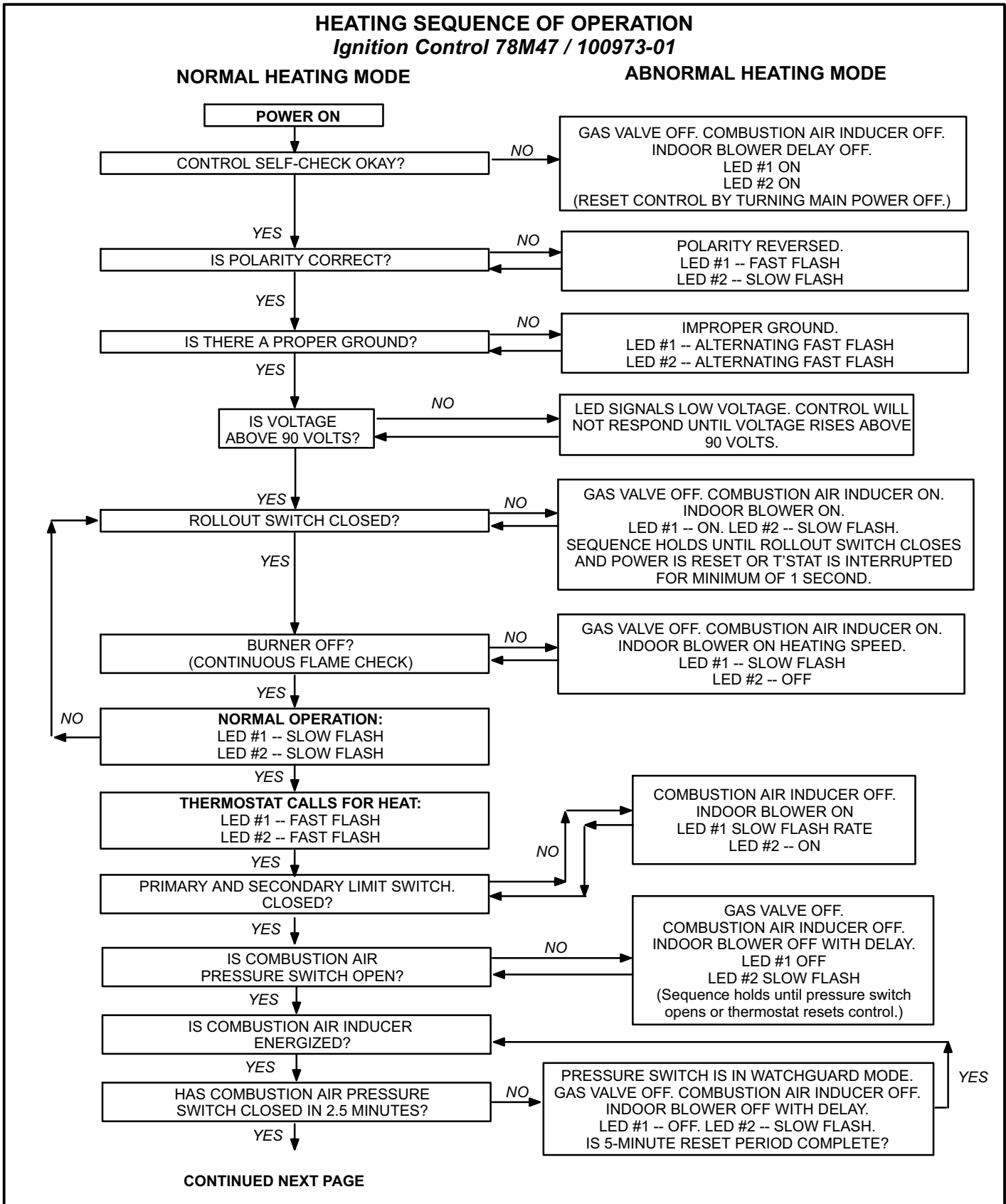
**CONTINUOUS FAN SEQUENCE OF OPERATION**  
*SureLight Control Board 32M88*





# G43UF Units with Ignition Control Board 78M47 or 100973-01

LED#1 = DS1 LED#2 = DS2 See Figure 8

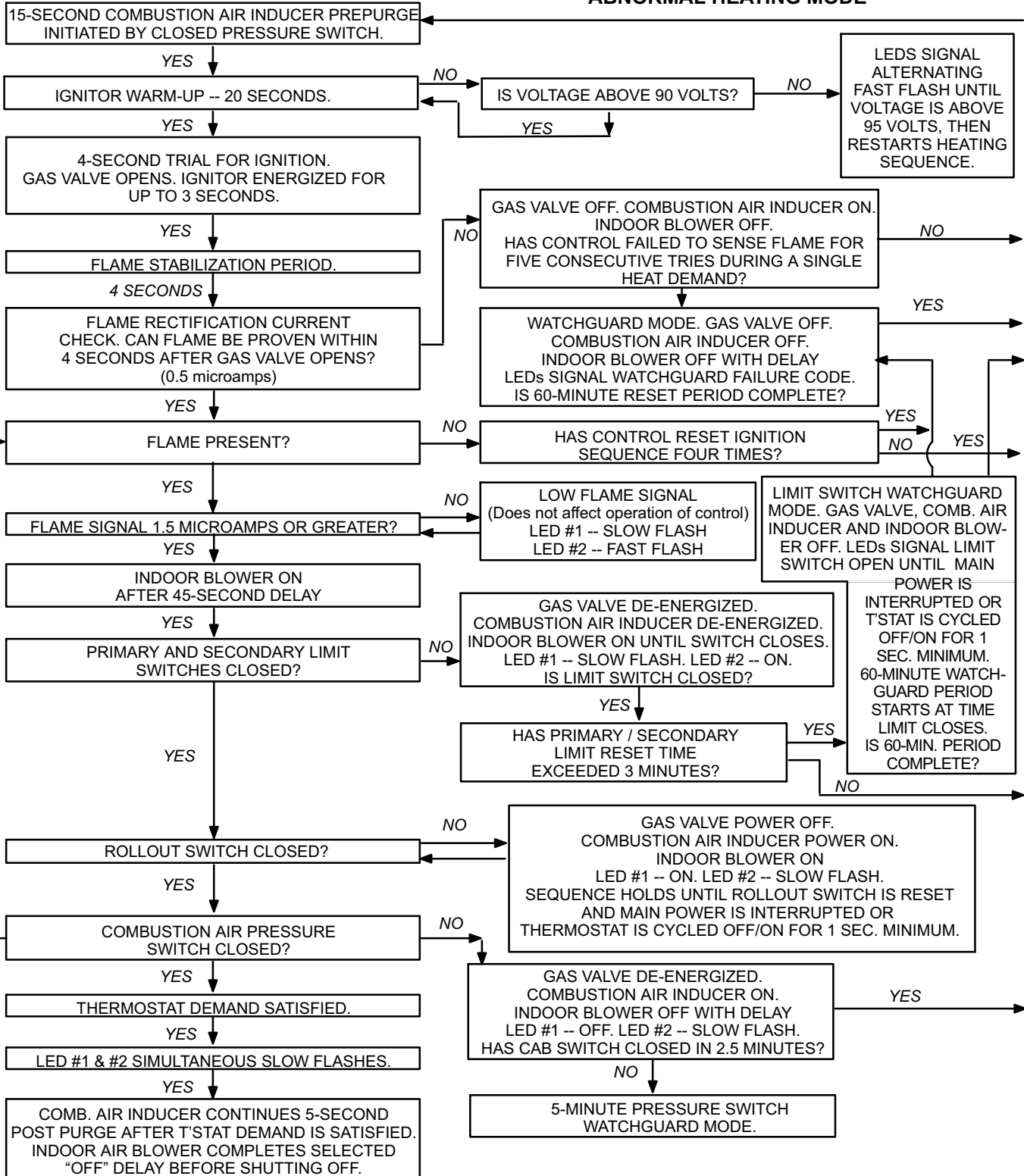


## HEATING SEQUENCE CONTINUED

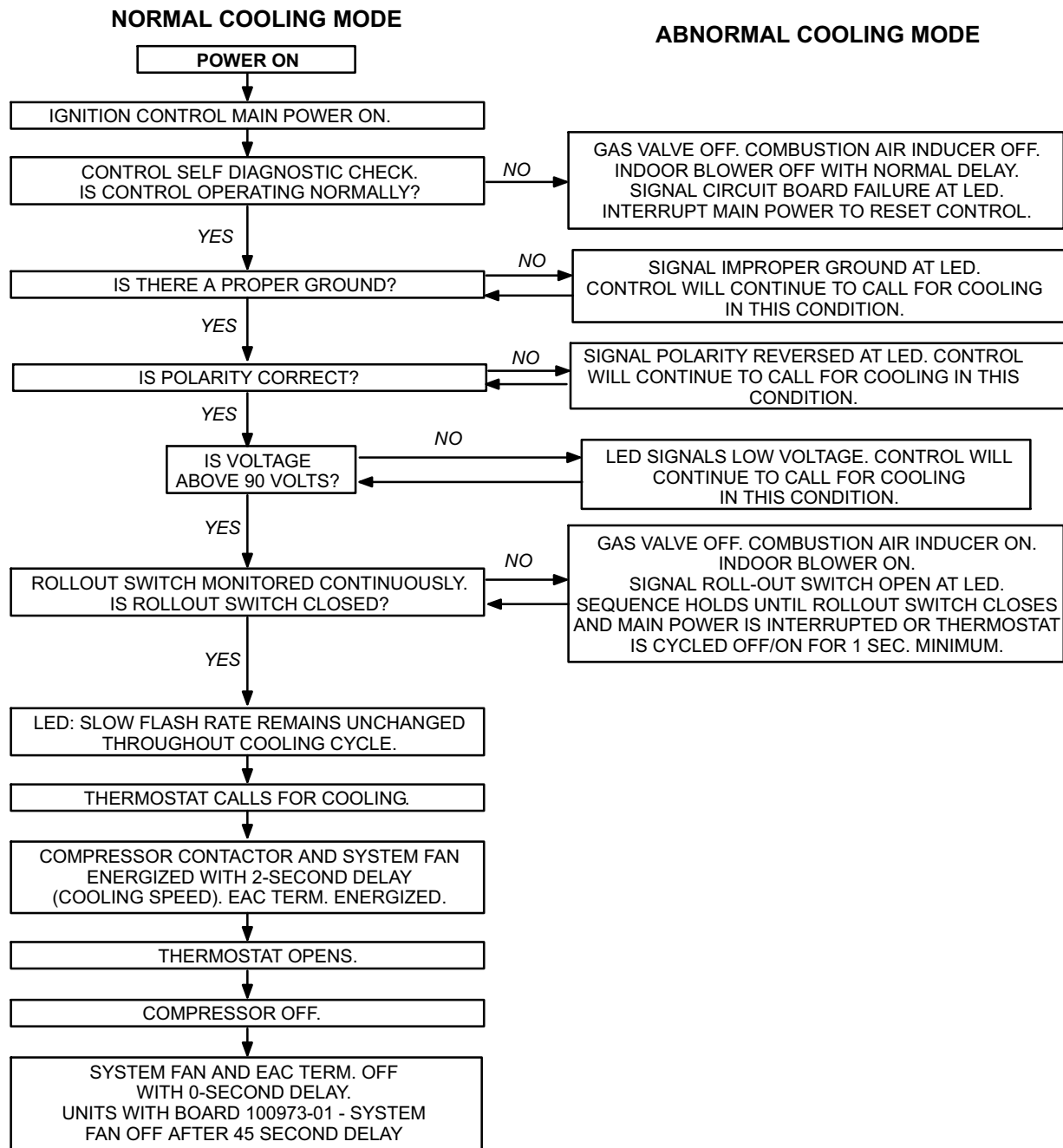
### Ignition Control 78M47 / 100973-01

#### NORMAL HEATING MODE

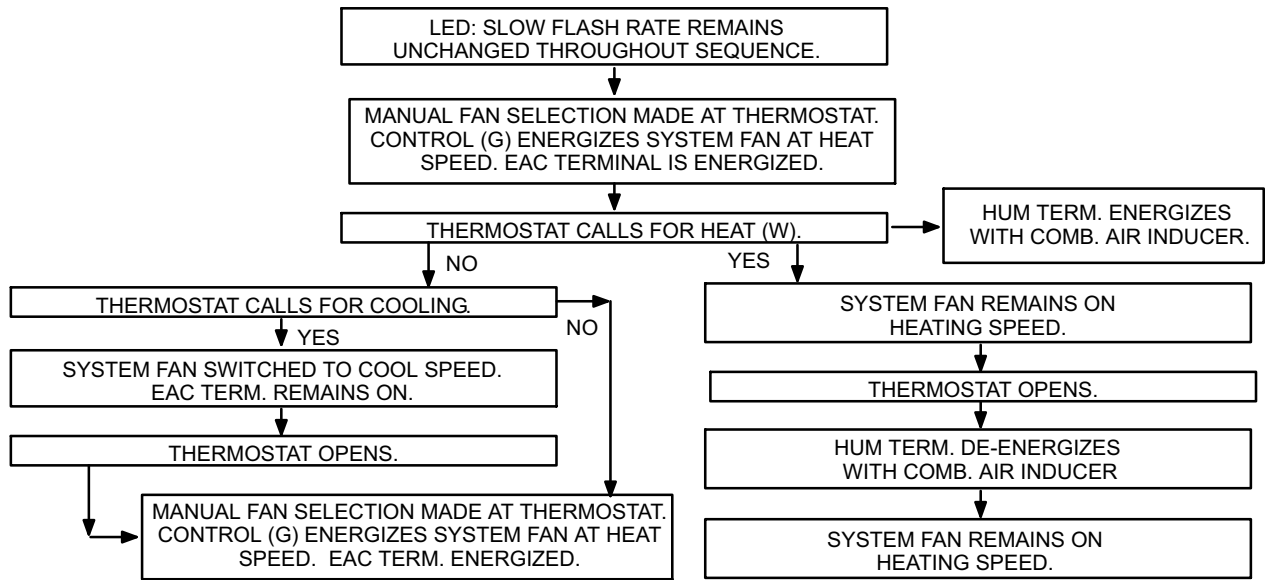
#### ABNORMAL HEATING MODE



**COOLING SEQUENCE OF OPERATION**  
*Ignition Control 78M47 / 100973-01*



**CONTINUOUS HEAT SPEED FAN SEQUENCE OF OPERATION**  
*Ignition Control 78M47 / 100973-01*



## VIII-Ignition Control Board Troubleshooting Chart

UPON INITIAL POWER UP, REMOVE ALL THERMOSTAT DEMANDS TO THE UNIT

<b>PROBLEM: 1 UNIT FAILS TO OPERATE IN THE COOLING, HEATING, OR CONTINUOUS FAN MODE</b>		
<b>Condition</b>	<b>Possible Cause</b>	<b>Corrective Action / Comments</b>
<b>1.1</b> - Both diagnostic lights fail to light up.  LED#1-Off LED#2-Off	<b>1.1.1</b> Main voltage 120V not supplied to unit.	<b>ACTION 1</b> - Check 120V main voltage. Determine cause of main power failure.
	<b>1.1.2</b> Miswiring of furnace or improper connections.	<b>ACTION 1</b> - Check for correct wiring of 120V to power make up box and transformer. <b>ACTION 2</b> - Check 24V wiring to control board.
	<b>1.1.3</b> Blown fuse	<b>ACTION 1</b> - Replace fuse. <b>ACTION 2</b> - If fuse still blows, check for short.
	<b>1.1.4</b> Door interlock switch failure.	<b>ACTION 1</b> - Check that door switch is activated when door is closed. <b>ACTION 2</b> - Check wire connections to switch, replace loose connectors. <b>ACTION 3</b> - Check continuity of switch in closed position. Replace if defective.
	<b>1.1.5</b> Transformer Failure.	<b>ACTION 1</b> - Check that transformer output is 24V. Replace if defective.
	<b>1.1.6</b> Failed control board.	<b>ACTION 1</b> - If all the above items have been checked, replace board.
<b>1.2</b> - Diagnostic lights flash the roll-out code.  LED#1-On, LED#2-Slow Flash	<b>1.2.1</b> Roll-out switch open.	<b>ACTION 1</b> - Manually reset the roll-out switch by pushing the top button. <b>ACTION 2</b> - Determine the cause of the roll-out switch activation before leaving furnace.
	<b>1.2.2</b> Roll-out switch failure.	<b>ACTION 1</b> - Check continuity across roll-out switch. Replace roll-out switch if switch is reset but does not have continuity.
	<b>1.2.3</b> Miswiring or improper connections at roll-out switch.	<b>ACTION 1</b> - Check wiring connections to switch.
	<b>1.2.4</b> 12 pin connector failure	<b>ACTION 1</b> - Check 12-pin connector for proper connection to control board. <b>ACTION 2</b> - Check continuity of the multi plug pin.
<b>1.3</b>  LED#1-Fast Flash, LED#2-Slow Flash.	<b>1.3.1</b> 120V main power polarity reversed.	<b>ACTION 1</b> - Check the 120V has line and neutral correctly input into control. <b>ACTION 2</b> - Reverse the line and neutral at the 120V field connection.
<b>1.4</b>  LED#1-Slow Flash LED#2-Slow Flash	<b>1.4.1</b> Open combustion air inducer motor circuit.	<b>ACTION 1</b> - Check for 120V to combustion air inducer. If no power, check wire and connections.
	<b>1.4.2</b> Failed combustion air inducer motor.	<b>ACTION 1</b> - If power is present at blower, replace blower.

<b>PROBLEM 1: UNIT FAILS TO OPERATE IN THE COOLING, HEATING, OR CONTINUOUS FAN MODE</b>		
<b>Condition</b>	<b>Possible Cause</b>	<b>Corrective Action / Comments</b>
<p><b>1.5</b></p> <p>- Diagnostic lights flash the improper main ground.</p> <p>LED#1-Alternating Fast Flash* LED#2-Alternating Fast Flash*</p>	<p><b>1.5.1</b></p> <p>Improper ground to the unit.</p>	<p><b>ACTION 1</b> - Check that the unit is properly ground.</p> <p><b>ACTION 2</b> - Install a proper main ground to the unit</p>
	<p><b>1.5.2</b></p> <p>4-Pin connector is improperly attached to the circuit board.</p>	<p><b>ACTION 1</b> - Check 4-pin connector for proper installation. Correctly insert connector into control.</p>
	<p><b>1.5.3</b></p> <p>Line voltage is below 75V <i>Board 32M88</i> Line voltage is below 90V <i>Board 78M47, 100973-01</i></p>	<p><b>ACTION 1</b> - Check that the line voltage is correct. Determine cause of voltage drop and supply correct voltage to the control.</p>
	<p><b>1.5.4</b></p> <p>Open ignitor circuit. <i>Board 32M88</i></p>	<p><b>ACTION 1</b> - Check for correct wiring and loose connections in the ignitor circuit. Check multi-plug connections for correct installation.</p>
	<p><b>1.5.5</b></p> <p>Broken or failed ignitor. <i>Board 32M88</i></p>	<p><b>ACTION 1</b> - Unplug ignitor and read resistance across ignitor. If resistance does not read between 10.9 and 19.7 ohms, replace the ignitor.</p>
<b>PROBLEM 2: UNIT FAILS TO FIRE IN THE HEATING MODE, COMBUSTION AIR BLOWER DOES NOT ENERGIZE</b>		
<b>Condition</b>	<b>Possible Cause</b>	<b>Corrective Action / Comments</b>
<p><b>2.1</b></p> <p>- Unit operates with a cooling or continuous fan demand.</p> <p>- Combustion air inducer will not start with a Heating demand.</p> <p>- Diagnostic lights flash the limit failure mode.</p> <p>LED#1-Slow Flash, LED#2-On</p>	<p><b>2.1.1</b></p> <p>Primary or secondary (if equipped ) limit open.</p>	<p><b>ACTION 1</b> - Check continuity across switch(es). Switches reset automatically upon cool down.</p> <p><b>ACTION 2</b> - Check for restrictions on blower inlet air (including filter) and outlet air. Determine cause for limit activation before placing unit back in operation.</p>
	<p><b>2.1.2</b></p> <p>Miswiring of furnace or improper connections at limit switch(es).</p>	<p><b>ACTION 1</b> - Check for correct wiring and loose connections. Correct wiring and/or replace any loose connections.</p>
<p><b>2.2</b></p> <p>- Unit operates with a cooling and continuous fan demand.</p> <p>- Combustion air inducer will not start with a Heating demand.</p> <p>- Diagnostic lights flash the pressure switch failure code.</p> <p>LED#1-Off, LED#2-Slow Flash</p>	<p><b>2.2.1</b></p> <p>Miswiring of furnace or improper connections to combustion air inducer.</p>	<p><b>ACTION 1</b> - Check for correct wiring and loose connections. Correct wiring and/or replace any loose connections.</p>
	<p><b>2.2.2</b></p> <p>Prove switch stuck closed.</p>	<p><b>ACTION 1</b> - Check that the prove switch is open without the combustion air inducer operating. Replace if defective.</p>

**PROBLEM 2: UNIT FAILS TO FIRE IN THE HEATING MODE, COMBUSTION AIR INDUCER DOES NOT ENERGIZE (CONT.).**

Condition	Possible Cause	Corrective Action/Comments
<b>2.3</b>	<b>2.3.1</b>	<p><b>ACTION 1</b> - Check for correct wiring and loose connections. Correct wiring and/or replace any loose connections.</p> <p><b>ACTION 1</b> - If there is 120V to combustion air inducer and it does not operate, replace combustion air inducer.</p>
<p>- Unit operates with a cooling and continuous fan demand.</p> <p>- Combustion air inducer will not start with a Heating demand.</p> <p>- Diagnostic lights flash the pressure switch failure code 2.5 minutes after heating demand.</p> <p>LED#1-Off, LED#2-Slow Flash</p>	<p>Miswiring of furnace or improper connections to combustion air inducer.</p>	
		<b>2.3.2</b>
	<p>Combustion air inducer failure.</p>	

**PROBLEM 3: UNIT FAILS TO FIRE IN THE HEATING MODE, COMBUSTION AIR INDUCER ENERGIZES, IGNITOR IS NOT ENERGIZED.**

Condition	Possible Cause	Corrective Action/Comments	
<b>3.1</b>	<b>3.1.1</b>	<p><b>ACTION 1</b> - Check that the prove switch lines are correctly routed. Correctly route pressure switch lines.</p> <p><b>ACTION 1</b> - Remove any obstructions from the the pressure lines and/or taps.</p> <p><b>ACTION 1</b> - Check prove switch lines for leaks. Replace any broken lines.</p> <p><b>ACTION 1</b> - Check prove switch lines for condensate. Remove condensate from lines.</p> <p><b>ACTION 1</b> - Check the differential pressure across the prove switch. This pressure should exceed the set point listed on the switch.</p> <p><b>ACTION 2</b> - Check for restricted inlet vent. Remove all blockage.</p> <p><b>ACTION 3</b> - Check for proper vent sizing and run length.</p> <p><b>ACTION 1</b> - Check that the proper prove switch is installed in the unit. Replace prove switch if necessary.</p> <p><b>ACTION 1</b> - Check for correct wiring and loose connections. Correct wiring and/or replace any loose connections.</p> <p><b>ACTION 1</b> - If all the above modes of failure have been checked, the prove switch may have failed. Replace prove switch and determine if unit will operate.</p>	
<p>- Unit operates with a cooling and continuous fan demand.</p> <p>- Combustion air inducer energizes with a heating demand.</p> <p>- Diagnostic lights flash the pressure switch failure code 2.5 minutes after heating demand.</p> <p>LED#1-Off LED#2-Slow Flash</p>	<p>Prove switch does not close due to incorrect routing of the pressure switch lines.</p>		
	<b>3.1.2</b>		<p>Prove switch does not close due to obstructions in the pressure lines.</p>
	<b>3.1.3</b>		<p>Prove switch lines damaged</p>
	<b>3.1.4</b>		<p>Condensate in prove switch line.</p>
	<b>3.1.5</b>		<p>Prove switch does not close due to a low differential pressure across the prove switch.</p>
	<b>3.1.6</b>		<p>Wrong prove switch installed in the unit, or prove switch is out of calibration.</p>
	<b>3.1.7</b>		<p>Miswiring of furnace or improper connections at prove switch.</p>
<b>3.1.8</b>	<p>Prove switch failure.</p>		

<b>PROBLEM 4: UNIT FAILS TO FIRE IN THE HEATING MODE, COMBUSTION AIR BLOWER ENERGIZES, IGNITOR IS ENERGIZED.</b>		
<b>Condition</b>	<b>Possible Cause</b>	<b>Corrective Action/Comments</b>
<p><b>4.1</b></p> <ul style="list-style-type: none"> <li>- Unit operates with a cooling and continuous fan demand.</li> <li>- Combustion air inducer energizes with Heating demand.</li> <li>- Ignitor is energized but unit fails to light.</li> </ul> <p>LED#1-Alternating Slow Flash LED#2-Alternating Slow Flash</p>	<p><b>4.1.1</b></p> <p>Check that gas is being supplied to the unit.</p>	<p><b>ACTION 1</b> - Check line pressure at the gas valve. Pressure should not exceed 13" WC for both natural and propane. Line pressure should read a minimum 4.5" WC for natural and 8.0"WC for propane.</p>
	<p><b>4.1.2</b></p> <p>Miswiring of gas valve or loose connections at multi-pin control amp plugs or valve.</p>	<p><b>ACTION 1</b> - Check for correct wiring and loose connections. Correct wiring and/or replace any loose connections.</p>
	<p><b>4.1.3</b></p> <p>Defective gas valve or ignition control.</p>	<p><b>ACTION 1</b> - Check that 24V is supplied to the gas valve approximately 35 seconds after heat demand is initiated. <b>ACTION 2</b> - Replace the valve if 24V is supplied but valve does not open. <b>ACTION 3</b> - Replace the control board if 24V is not supplied to valve.</p>
<b>PROBLEM 5: BURNERS LIGHT WITH A HEATING DEMAND BUT UNIT SHUTS DOWN PREMATURELY</b>		
<b>Condition</b>	<b>Possible Cause</b>	<b>Corrective Action/Comments</b>
<p><b>5.1</b></p> <ul style="list-style-type: none"> <li>- Burners fire with a heating demand.</li> <li>- Burners light but unit shuts off prior to satisfying T-stat demand.</li> <li>- Diagnostic lights flash the pressure switch code.</li> </ul> <p>LED#1-Off LED#2-Slow Flash</p>	<p><b>5.1.1</b></p> <p>Low pressure differential at the prove switch.</p>	<p><b>ACTION 1</b> - Check for restricted exhaust vent. Remove all blockage. <b>ACTION 2:</b> Check for proper vent sizing. See installation instructions.</p>
	<p><b>5.1.2</b></p> <p>Wrong concentric vent kit used for terminating the unit.</p>	<p><b>ACTION 1</b> - Check vent termination kit installed. See Placement and Installation section.</p>
	<p><b>5.1.3</b></p> <p>Condensate drain line is not draining properly.</p>	<p><b>ACTION 1</b> - Check condensate line for proper vent slope, and any blockage. Condensate should flow freely during operation of furnace. Repair or replace any improperly installed condensate lines.</p>
	<p><b>5.1.4</b></p> <p>Low pressure differential at the prove switch.</p>	<p><b>ACTION 1</b> - Check for restricted exhaust. Remove all blockage. <b>ACTION 2:</b> Check for proper vent sizing. See installation instructions.</p>
<p><b>5.2</b></p> <ul style="list-style-type: none"> <li>- Combustion air inducer energizes with a heating demand.</li> <li>- Burners light but fail to stay lit.</li> <li>- After 5 tries the control diagnostics flash the watchguard burners failed to ignite code.</li> </ul> <p>LED#1-Alternating Slow Flash LED#2-Alternating Slow Flash</p>	<p><b>5.2.1</b></p> <p>Sensor or sense wire is improperly installed.</p>	<p><b>ACTION 1</b> - Check that sensor is properly located and that the sense wire is properly attached to both the sensor and the control.</p>
	<p><b>5.2.2</b></p> <p>Sensor or sense wire is broken.</p>	<p><b>ACTION 1</b> - Check for a broken sensor. <b>ACTION 2</b> - Test continuity across the sense wire. If wire or sensor are damaged replace the component.</p>
	<p><b>5.2.3</b></p> <p>Sensor or sensor wire is grounded to the unit.</p>	<p><b>ACTION 1</b> - Check for resistance between the sensor rod and the unit ground. <b>ACTION 2</b> - Check for resistance between the sensor wire and the unit ground. <b>ACTION 3</b> - Correct any shorts found in circuit.</p>
	<p><b>5.2.4</b></p> <p>Control does not sense flame.</p>	<p><b>ACTION 1</b> - Check the microamp signal from the burner flame. If the microamp signal is below normal, check the sense rod for proper location or contamination. <b>ACTION 2</b> - Replace, clean, or relocate flame sense rod. If rod is to be cleaned, use steel wool or replace sensor. <b>DO NOT CLEAN ROD WITH SAND PAPER. SAND PAPER WILL CONTRIBUTE TO THE CONTAMINATION PROBLEM. NOTE:</b> Do not attempt to bend sense rod.</p>

**PROBLEM 5: BURNERS LIGHT WITH HEATING DEMAND BUT UNIT SHUTS DOWN  
PREMATURELY (CONT.)**

Condition	Possible Cause	Corrective Action/Comments
<p align="center"><b>5.3</b></p> <ul style="list-style-type: none"> <li>- Combustion air inducer energizes with a heating demand.</li> <li>- Burners light.</li> <li>- Roll-out switch trips during the heating demand.</li> <li>- Diagnostic lights flash roll-out failure.</li> </ul> <p>LED#1-On LED#2-Slow Flash</p>	<p align="center"><b>5.3.1</b></p> <p align="center">Unit is firing above 100% of the nameplate input.</p>	<p><b>ACTION 1</b> - Check that the manifold pressure matches value listed on nameplate. See installation instructions for proper procedure.</p> <p><b>ACTION 2</b> - Verify that the installed orifice size match the size listed on the nameplate or installation instructions.</p> <p><b>ACTION 3</b> - Check gas valve sensing hose to insure no leaks are present.</p> <p><b>ACTION 4</b> - Check the input rate to verify rate matches value listed on nameplate.</p>
	<p align="center"><b>5.3.2</b></p> <p align="center">Gas orifices leak at the manifold connection.</p>	<p><b>ACTION 1</b> - Tighten orifice until leak is sealed.</p> <p><b>NOTE:</b> Be careful not to strip orifice threads.</p> <p><b>ACTION 2</b> - Check for gas leakage at the threaded orifice connection. Use approved method for leak detection (see unit instructions).</p>
	<p align="center"><b>5.3.3</b></p> <p align="center">Air leakage at the connections between the primary heat exchanger, secondary heat exchanger, and combustion air blower.</p>	<p><b>ACTION 1</b> - Check for air leakage at all joints in the heat exchanger assembly. Condition will cause high CO<sub>2</sub> with high CO.</p> <p><b>ACTION 2</b> - Seal leakage if possible, replace heat exchanger if necessary, tag and return heat exchanger to proper Lennox personnel.</p>
	<p align="center"><b>5.3.4</b></p> <p align="center">Insufficient flow through the heat exchanger caused by a sooted or restricted heat exchanger.</p>	<p><b>ACTION 1</b> - Check for sooting deposits or other restrictions in the heat exchanger assembly. Clean assembly as outlined in instruction manual.</p> <p><b>ACTION 2</b> - Check for proper combustion.</p>
	<p align="center"><b>5.3.5</b></p> <p align="center">Burners are not properly located in the burner box.</p>	<p><b>ACTION 1</b> - Check that the burners are firing into the center of the heat exchanger openings. Correct the location of the burners if necessary.</p>
<p align="center"><b>5.4</b></p> <ul style="list-style-type: none"> <li>- Combustion air inducer energizes with a heating demand.</li> <li>- Burners light roughly and the unit fails to stay lit.</li> <li>- Diagnostic lights flash watchguard flame failure.</li> </ul> <p>LED#1-Alternating Slow Flash LED#2-Alternating Slow Flash</p>	<p align="center"><b>5.4.1</b></p> <p align="center">Recirculation of flue gases. This condition causes rough ignitions and operation. Problem is characterized by nuisance flame failures.</p>	<p><b>ACTION 1</b> - Check for proper flow of exhaust gases away from intake vent. Remove any obstacles in front of the intake and exhaust vent which would cause recirculation.</p> <p><b>ACTION 2</b> - Check for correct intake and exhaust vent installation. See instructions</p>
	<p align="center"><b>5.4.2</b></p> <p align="center">Improper burner cross-overs</p>	<p><b>ACTION 1</b> - Remove burner and inspect the cross-overs for burrs, or any restriction or if crossover is warped. Remove restriction or replace burners.</p>
	<p align="center"><b>5.4.3</b></p> <p align="center">Prove Switch opens 5 times during a single demand</p>	<p><b>ACTION 1</b> - Inspect vent pipe installation and for any restriction. Remove restriction.</p> <p><b>ACTION 2</b> - Check prove switch reliability.</p>

<b>PROBLEM 6: CONTROL SIGNALS LOW FLAME SENSE DURING HEATING MODE</b>		
<b>Condition</b>	<b>Possible Cause</b>	<b>Corrective Action/Comments</b>
<p><b>6.0</b></p> <p>- Unit operates correctly but the diagnostic lights flash low flame sense code.</p> <p>LED#1-Slow Flash LED#2-Fast Flash</p>	<p><b>6.1.1</b></p> <p>Sensor rod is improperly located on the burner.</p>	<p><b>ACTION 1</b> - Check the sensor rod for proper location on the burner. Properly locate the sensor rod or replace if rod cannot be located correctly.</p>
	<p><b>6.1.2</b></p> <p>Sensor rod is contaminated.</p>	<p><b>ACTION 1</b> - Check sensor rod for contamination or coated surface. Clean the sensor rod with steel wool or replace sensor. DO NOT USE SAND PAPER TO CLEAN ROD. SAND PAPER WILL CONTRIBUTE TO THE CONTAMINATION PROBLEM.</p>
<b>PROBLEM 7: INDOOR BLOWER FAILS TO OPERATE IN COOLING, HEATING, OR CONTINUOUS FAN MODE</b>		
<b>Condition</b>	<b>Possible Cause</b>	<b>Corrective Action/Comments</b>
<p><b>7.0</b></p> <p>- Indoor blower fails to operate in continuous fan, cooling, or heating mode.</p>	<p><b>7.1.1</b></p> <p>Miswiring of furnace or improper connections at control or indoor blower motor.</p>	<p><b>ACTION 1</b> - Correct wiring and/or replace any loose connections. Check for correct wiring and loose connections.</p>
	<p><b>7.1.2</b></p> <p>120V is not being supplied to the indoor air blower or blower motor failure.</p>	<p><b>ACTION 1</b> - Check for 120V at the various calls for indoor blower by energizing "Y", "G", and "W" individually on the low voltage terminal strip. Note that when "W" is energized, the blower is delayed 45 seconds. If there is 120V to each motor tap but the blower does not operate, replace the motor.</p>
	<p><b>7.1.3</b></p> <p>Defective control board</p>	<p><b>ACTION 1</b> - If there is not 120V when "Y", "G", or "W" is energized, replace the control.</p>
	<p><b>7.1.4</b></p> <p>Defective run capacitor</p>	<p><b>ACTION 1</b> - Replace capacitor</p>
<b>PROBLEM 8: RF STATIC DURING TIME FOR IGNITION</b>		
<b>Condition</b>	<b>Possible Cause</b>	<b>Corrective Action/Comments</b>
<p><b>8.0</b></p> <p>- AM radio interference.</p>	<p><b>8.1.2</b></p> <p>Ignitor operation</p>	<p><b>ACTION 1</b> - Call Technical Support, Dallas.</p>