

AC13 SERIES UNITS

The AC13 is a high efficiency residential split-system condensing unit, which features a scroll compressor. AC13 units are available in sizes ranging from 1-1/2 through 5 tons. The series is designed for use with an expansion valve or RFC (approved for use with R-22) in the indoor unit. This manual is divided into sections which discuss the major components, refrigerant system, charging procedure, maintenance and operation sequence.

Information contained in this manual is intended for use by qualified service technicians only. All specifications are subject to change.



⚠ WARNING

Improper installation, adjustment, alteration, service or maintenance can cause property damage, personal injury or loss of life. Installation and service must be performed by a qualified installer or service agency.

⚠ WARNING

Warranty will be voided if covered equipment is removed from original installation site. Warranty will not cover damage or defect resulting from: Flood, wind, lightning, or installation and operation in a corrosive atmosphere (chlorine, fluorine, salt, recycled waste water, urine, fertilizers, or other damaging chemicals).

⚠ DANGER



Shock Hazard
Remove all power at disconnect before removing access panel. Single phase AC13 units use single-pole contactors. Potential exists for electrical shock resulting in injury or death. Line voltage exists at all components (even when unit is not in operation).

TABLE OF CONTENTS

General Page 1
 Specifications / Electrical Data Page 2
 I Application Page 3
 II Unit Components Page 3
 III Refrigeration System Page 7
 IV Charging Page 8
 VI Maintenance Page 15
 VII Wiring and Sequence of Operation . Page 16

SPECIFICATIONS

General Data		Model No.	AC13-018	AC13-024	AC13-030	AC13-036	AC13-042	AC13-048-4 -1 / -3 units	AC13-060
Nominal Tonnage (kW)			1.5 (5.3)	2 (7.0)	2.5 (8.8)	3 (10.6)	3.5 (12.3)	4 (14.1)	5 (17.6)
Connections (sweat)	Liquid line o.d. - in. (mm)		3/8 (9.5)	3/8 (9.5)	3/8 (9.5)	3/8 (9.5)	3/8 (9.5)	3/8 (9.5)	3/8 (9.5)
	Suction line o.d. - in. (mm)		3/4 (19.1)	3/4 (19.1)	3/4 (19.1)	7/8 (22.2)	7/8 (22.2)	7/8 (22.2)	1-1/8 (28.6)
¹ Refrigerant (R-22) furnished			4 lbs. 0 oz. (1.81 kg)	4 lbs. 8 oz. (2.04 kg)	5 lbs. 5 oz. (2.41 kg)	6 lbs. 15 oz. (3.15 kg)	6 lbs. 15 oz. (3.15 kg)	9 lbs 8 oz (4.31) 9 lbs. 12 oz. (4.42 kg)	13 lbs. 6 oz. (6.07 kg)
Outdoor Coil	Net face area - sq. ft. (m ²)	Outer coil	13.22 (1.23)	15.11 (1.40)	13.22 (1.23)	13.22 (1.23)	15.11 (1.40)	18.67 (1.73) 21.00 (1.95)	24.50 (2.28)
		Inner coil	---	---	12.60 (1.17)	12.60 (1.17)	14.40 (1.34)	18.0 (1.67) 20.27 (1.88)	23.56 (2.19)
Tube diameter - in. (mm)			5/16 (8)	5/16 (8)	5/16 (8)	5/16 (8)	5/16 (8)	5/16 (8)	5/16 (8)
Number of rows			1	1	2	2	2	2	2
Fins per inch (m)			22 (866)	22 (866)	22 (866)	22 (866)	22 (866)	22 (866)	22 (866)
Outdoor Fan	Diameter - in. (mm)		18 (457)	18 (457)	18 (457)	18 (457)	18 (457)	22 (559)	22 (559)
	Number of blades		3	3	4	4	4	4	4
	Motor hp (W)		1/5 (149)	1/5 (149)	1/5 (149)	1/5 (149)	1/3 (249)	1/4 (186)	1/4 (186)
	Cfm (L/s)		2500 (1180)	2500 (1180)	2450 (1155)	2450 (1155)	2930 (1385)	3830 (1805)	3830 (1805)
	Rpm		1100	1100	1100	1100	1100	825	825
	Watts		200	200	200	200	310	330	330
Shipping Data - lbs. (kg) 1 package			154 (55)	164 (59)	179 (68)	180 (68)	210 (80)	260 (106)	287 (107)

ELECTRICAL DATA

Line voltage data - 60 hz - 1ph		208/230V	208/230V	208/230V	208/230V	208/230V	208/230V	208/230V
² Maximum overcurrent protection (amps)		15	20	30	30	45	40	60
³ Minimum circuit ampacity		10.7	14.1	18.7	19.1	25.9	25.7	33.3
Compressor	Rated load amps	7.7	10.4	14.1	14.4	19.2	19.2	26.1
	Power factor	.98	.96	.96	.96	.98	.94	.96
	Locked rotor amps	40.3	54.0	67.0	77.0	104.0	97.0	141.0
Condenser Fan Motor	Full load amps	1.0	1.0	1.0	1.0	1.9	1.7	1.7
	Locked rotor amps	1.9	1.9	1.9	1.9	4.1	3.1	3.1

OPTIONAL ACCESSORIES - must be ordered extra

Compressor Crankcase Heater	93M04 93M05	•	•	•	•			
Compressor Hard Start Kit	10J42 88M91	•						
Compressor Low Ambient Cut-Off	45F08	•	•	•	•	•	•	•
Compressor Sound Cover	69J03	•	•	•	•	•	•	•
Compressor Time-Off Control	47J27	•	•	•	•	•	•	•
Freezestat	3/8 in. tubing	93G35	•	•	•	•	•	•
	5/8 in. tubing	50A93	•	•	•	•	•	•
High Pressure Switch Kit	94J46	•	•	•	•	•	•	•
Loss of Charge Switch Kit	84M23	•	•	•	•	•	•	•
⁵ Low Ambient Kit	24H77	•	•	•	•	•	•	•
Refrigerant Line Sets	L15-41-20, L15-41-30, L15-41-40, L15-41-50	•	•	•				
	L15-65-30, L15-65-40, L15-65-50				•	•	•	
	Field Fabricate							•
Time Delay Relay Kit	58M81	•	•	•	•	•	•	•

NOTE — Extremes of operating range are plus 10% and minus 5% of line voltage.

¹ Refrigerant charge sufficient for 15 ft. (4.6 m) length of refrigerant lines.

² HACR type circuit breaker or fuse.

³ Refer to National or Canadian Electrical Code manual to determine wire, fuse and disconnect size requirements.

⁵ Crankcase Heater and Freezestat are recommended with Low Ambient Kit.

I - APPLICATION

AC13 condensing units are available in 1-1/2, 2, 2 -1/2, 3, 3 -1/2, 4 and 5 ton capacities. All major components (indoor blower and coil) must be matched according to Lennox recommendations for the compressor to be covered under warranty. Refer to the Engineering Handbook for approved system matchups.

II - UNIT COMPONENTS

Unit components are illustrated in figure 1.

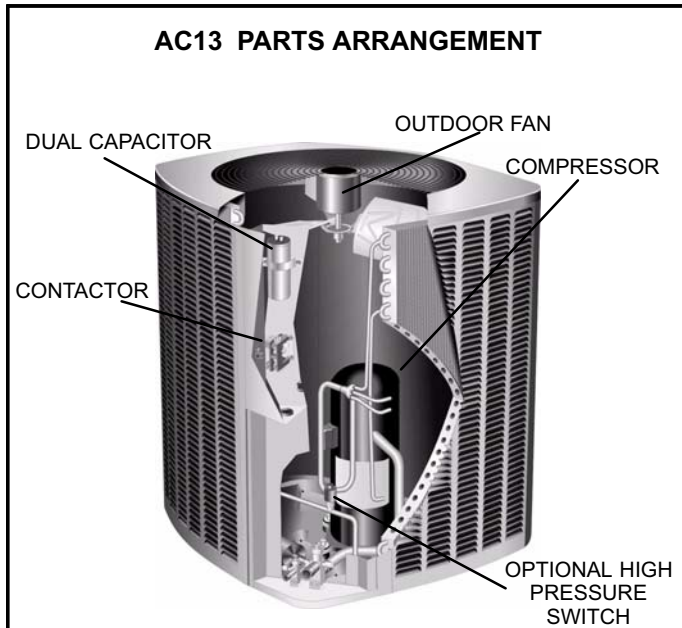

FIGURE 1

⚠ CAUTION

To prevent personal injury, or damage to panels, unit or structure, be sure to observe the following:

While installing or servicing this unit, carefully stow all removed panels out of the way, so that the panels will not cause injury to personnel, nor cause damage to objects or structures nearby, nor will the panels be subjected to damage (e.g., being bent or scratched).

While handling or stowing the panels, consider any weather conditions, especially windy conditions, that may cause panels to be blown around and battered.

Remove the louvered panels as follows:

- 1 - Remove 2 screws, allowing the panel to swing open slightly (see figure 2).
- 2 - **Hold the panel firmly throughout this procedure.** Rotate bottom corner of panel away from hinge corner post until lower 3 tabs clear the slots (see figure 2, Detail B).
- 3 - Move panel down until lip of upper tab clears the top slot in corner post (see figure 2, Detail A).

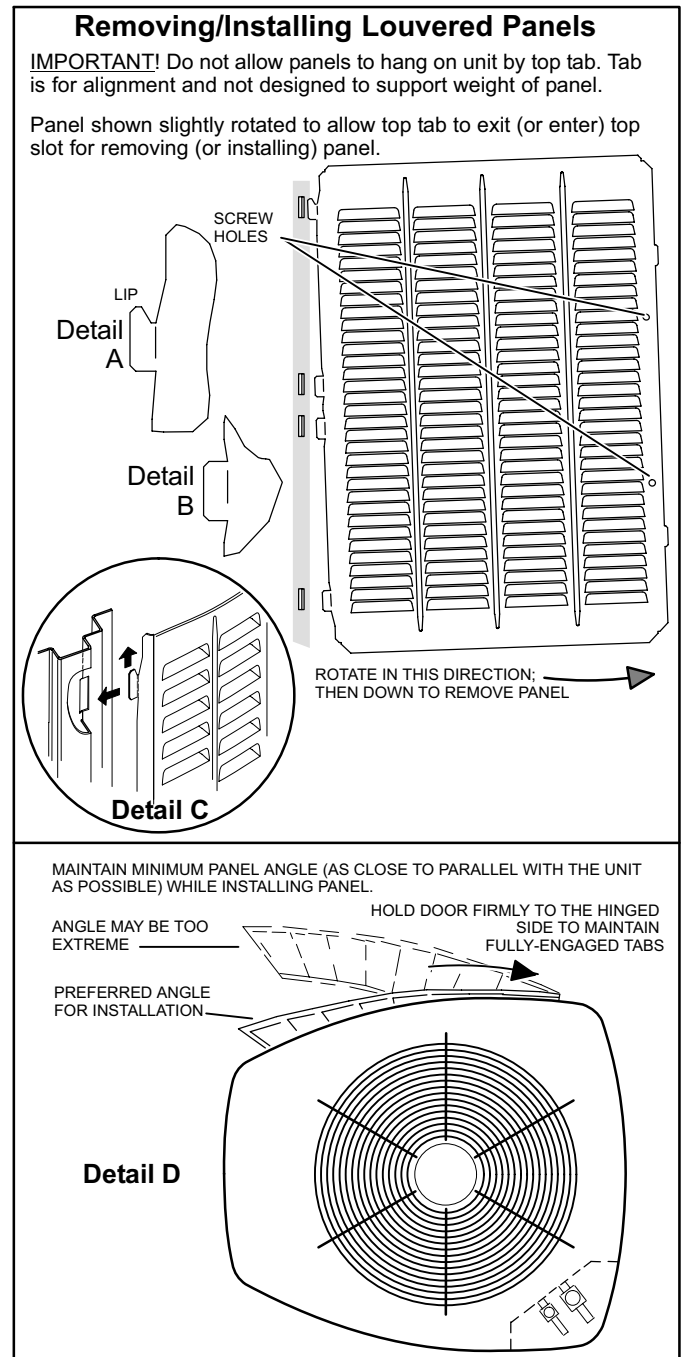

FIGURE 2

Position and Install Panel—Position the panel almost parallel with the unit (figure 2, Detail D) with the “screw side” as close to the unit as possible. Then, in a continuous motion:

- Slightly rotate and guide the lip of top tab inward (figure 2, Details A and C); then upward into the top slot of the hinge corner post.
- Rotate panel to vertical to fully engage all tabs.
- Holding the panel’s hinged side firmly in place, close the right-hand side of the panel, aligning the screw holes.

When panel is correctly positioned and aligned, insert the screws and tighten.

A - Control Box (Figure 3)

AC13 units are not equipped with a 24V transformer. All 24 VAC controls are powered by the indoor unit. Refer to wiring diagram.

Electrical openings are provided under the control box cover. Field thermostat wiring is made to color-coded pigtail connections.

ELECTROSTATIC DISCHARGE (ESD) Precautions and Procedures

⚠ CAUTION

Electrostatic discharge can affect electronic components. Take precautions during unit installation and service to protect the unit's electronic controls. Precautions will help to avoid control exposure to electrostatic discharge by putting the unit, the control and the technician at the same electrostatic potential. Neutralize electrostatic charge by touching hand and all tools on an unpainted unit surface before performing any service procedure.

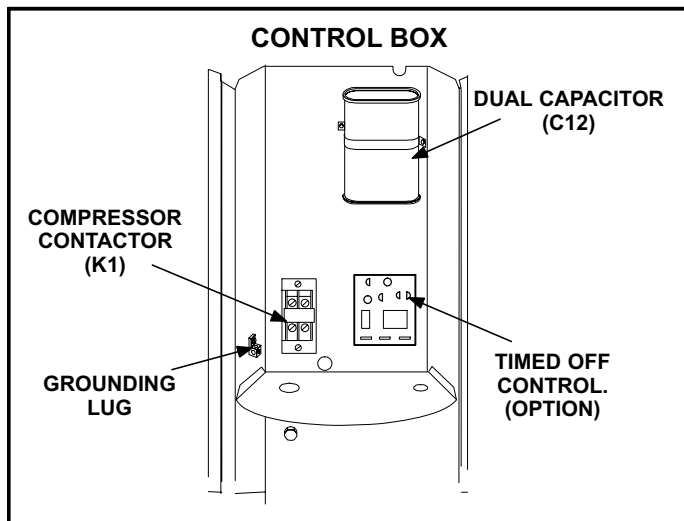

FIGURE 3

1 - Compressor Contactor K1

The compressor is energized by a single-pole contactor located in the control box. See figure 3. K1 is energized by the indoor thermostat terminal Y1 (24V) when thermostat demand is present.

2 - Dual Capacitor C12

The compressor and fan in AC13 series units use permanent split capacitor motors. The capacitor is located inside the unit control box (see figure 3). A single "dual" capacitor (C12) is used for both the fan motor and the compressor (see unit wiring diagram). The fan side and the compressor side of the capacitor have different MFD ratings. See side of capacitor for ratings.

3 - Timed Off Control TOC (option)

The time delay is electrically connected between thermostat terminal Y and the compressor contactor. Between cycles, the compressor contactor is delayed for 5 minutes \pm 2 minutes but may last as long as 8 minutes. At the end of the delay, the compressor is allowed to energize. When thermostat demand is satisfied, the time delay opens the circuit to the compressor contactor coil and the compressor is de-energized.

B - Compressor

The scroll compressor design is simple, efficient and requires few moving parts. A cutaway diagram of the scroll compressor is shown in figure 4. The scrolls are located in the top of the compressor can and the motor is located just below. The oil level is immediately below the motor.

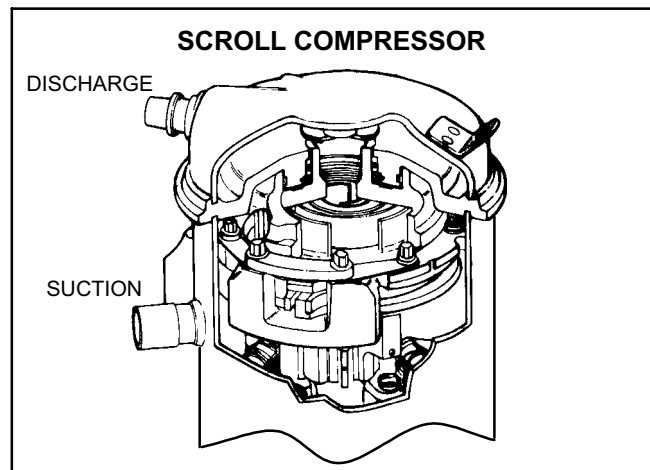

FIGURE 4

The scroll is a simple compression concept centered around the unique spiral shape of the scroll and its inherent properties. Figure 5 shows the basic scroll form. Two identical scrolls are mated together forming concentric spiral shapes (figure 6). One scroll remains stationary, while the other is allowed to "orbit" (figure 7). Note that the orbiting scroll does not rotate or turn but merely orbits the stationary scroll.

NOTE - During operation, the head of a scroll compressor may be hot since it is in constant contact with discharge gas.

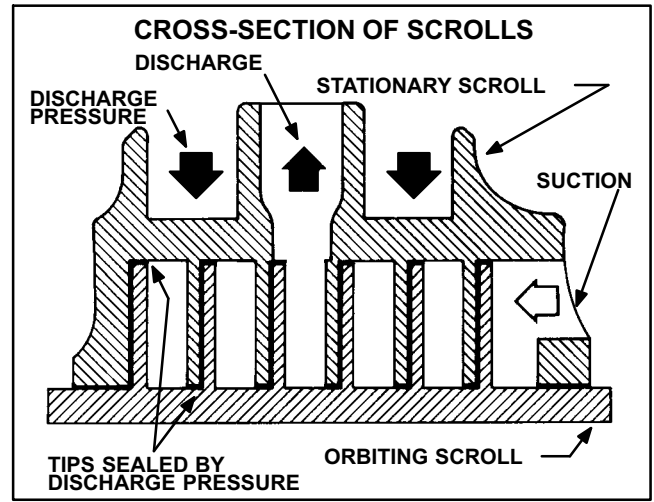

FIGURE 6

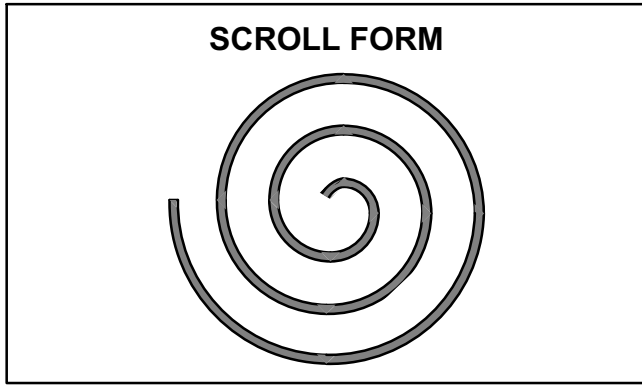

FIGURE 5

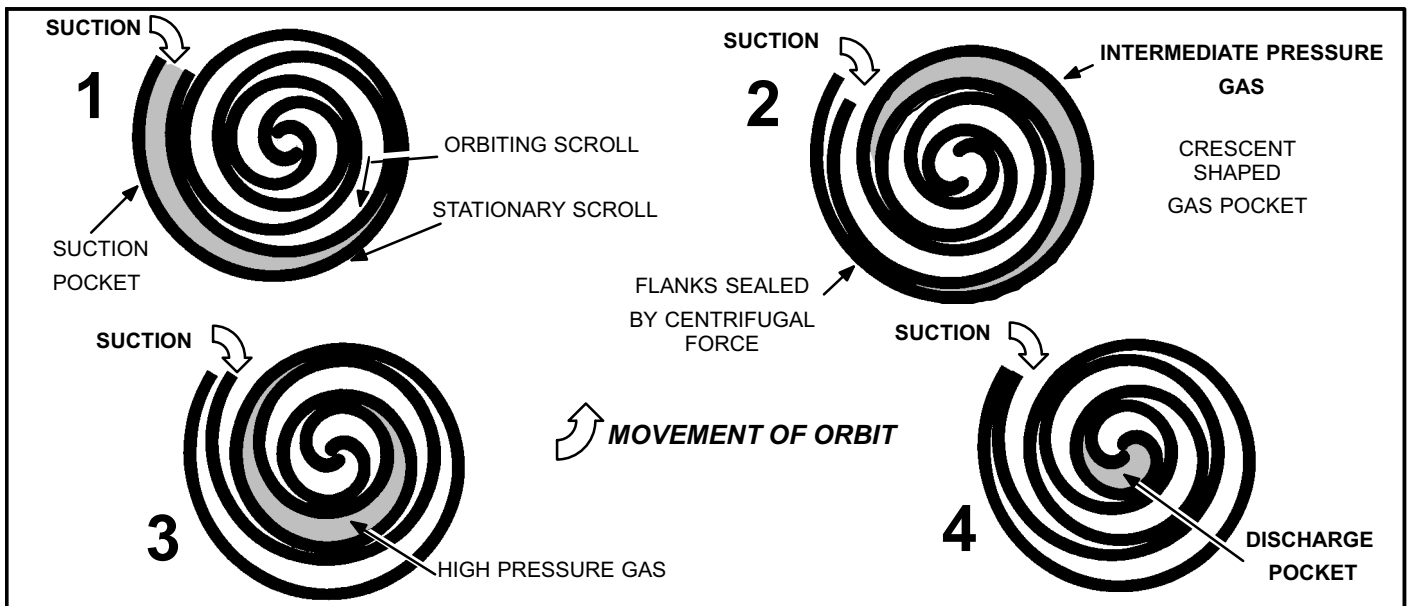

FIGURE 7

The counterclockwise orbiting scroll draws gas into the outer crescent shaped gas pocket created by the two scrolls (figure 7 - 1). The centrifugal action of the orbiting scroll seals off the flanks of the scrolls (figure 7 - 2). As the orbiting motion continues, the gas is forced toward the center of the scroll and the gas pocket becomes compressed (figure 7 - 3). When the compressed gas reaches the center, it is discharged vertically into a chamber and discharge port in the top of the compressor (figure 6). The discharge pressure forcing down on the top scroll helps seal off the upper and lower edges (tips) of the scrolls (figure 6). During a single orbit, several pockets of gas are compressed simultaneously providing smooth continuous compression.

The scroll compressor is tolerant to the effects of liquid return. If liquid enters the scrolls, the orbiting scroll is allowed to separate from the stationary scroll. The liquid is worked toward the center of the scroll and is discharged. If the compressor is replaced, conventional Lennox cleanup practices must be used.

Due to its efficiency, the scroll compressor is capable of drawing a much deeper vacuum than reciprocating compressors. Deep vacuum operation can cause internal fusite arcing resulting in damaged internal parts and will result in compressor failure. Never use a scroll compressor for evacuating or "pumping-down" the system. This type of damage can be detected and will result in denial of warranty claims.

The scroll compressor is quieter than a reciprocating compressor, however, the two compressors have much different sound characteristics. The sounds made by a scroll compressor do not affect system reliability, performance, or indicate damage.

C - Condenser Fan Motor

All units use single-phase PSC fan motors which require a run capacitor. In all units, the condenser fan is controlled by the compressor contactor.

ELECTRICAL DATA tables in this manual show specifications for condenser fans used in AC13 's.

Access to the condenser fan motor on all units is gained by removing the four screws securing the fan assembly. See figure 8. The grill fan assembly can be removed from the cabinet as one piece. See figure 9. The condenser fan motor is removed from the fan guard by removing the four nuts found on top of the grill. See figure 9 if condenser fan motor replacement is necessary.

⚠ DANGER

Make sure all power is disconnected before beginning electrical service procedures.

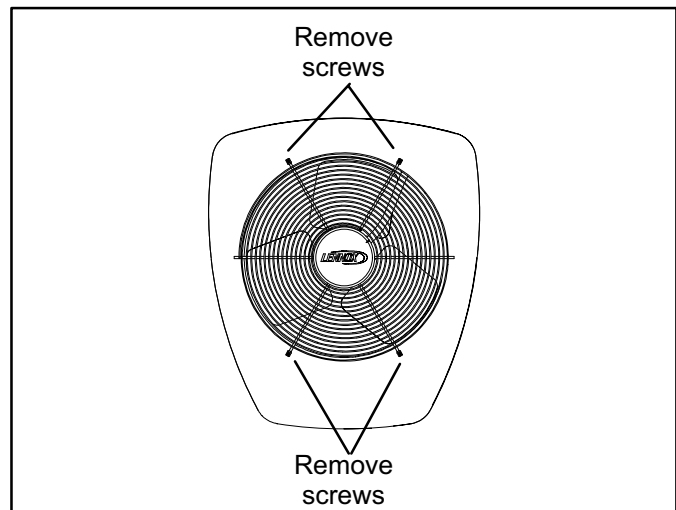

FIGURE 8

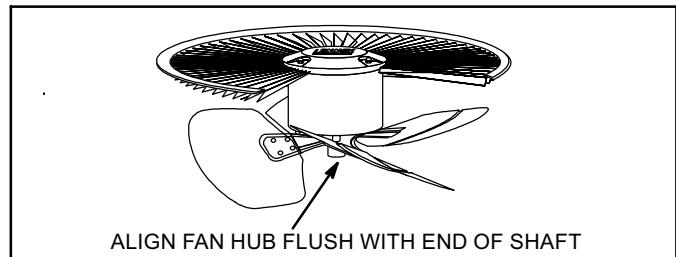

FIGURE 9

D - Loss of Charge Switch (option)

An auto-reset, single-pole/single-throw low loss of charge switch is located in the suction line. This switch shuts off the compressor when suction pressure drops below the factory setting. The switch is closed during normal operating pressure conditions and is permanently adjusted to trip (open) at 25 ± 5 psi. The switch automatically resets when suction line pressure rises above 55 ± 5 psi.

rises to 55 ± 5 psig.

E - High Pressure Switch (option)

AC13 units are equipped with a high pressure switch that is located in the liquid line. The switch (SPST, manual reset, normally closed) removes power from the compressor contactor control circuit when discharge pressure rises above factory setting at 410 ± 10 psi.

III - REFRIGERANT SYSTEM

A - Plumbing

Field refrigerant piping consists of liquid and suction lines from the condensing unit (sweat connections) to the indoor evaporator coil (sweat connections). Use Lennox L15 (sweat) series line sets as shown in table 1.

TABLE 1

Unit	Liquid Line	Suction Line	L15 Line Sets
-018 -024 -030	3/8 in. (10 mm)	3/4 in. (19 mm)	L15-41 15 ft. - 50 ft. (4.6 m - 15 m)
-036 -042 -048	3/8 in. (10 mm)	7/8 in. (22 mm)	L15-65 15 ft. - 50 ft. (4.6 m - 15 m)
-060	3/8 in. (10 mm)	1-1/8 in. (29 mm)	Field Fabricated

The liquid line and vapor line service valves (figures 10 and 11) and gauge ports are accessible from the outside of the unit. Use the service ports for leak testing, evacuating, charging and checking charge.

Each valve is equipped with a service port which has a factory-installed Schrader valve. A service port cap protects the Schrader valve from contamination and serves as the primary leak seal. *Service valves are not rebuildable. If a valve has failed, you must replace it.*

To Access Schrader Port:

- 1 - Remove service port cap with an adjustable wrench.
- 2 - Connect gauge to the service port.
- 3 - When testing is complete, replace service port cap. Tighten finger tight, then an additional 1/6 turn.

To Open Service Valve:

- 1 - Remove the stem cap with an adjustable wrench.
- 2 - Using the adjustable wrench to keep the valve stationary, use a service wrench with a hex-head extension to back the stem out counterclockwise as far as it will go.
NOTE - Use a 3/16" hex head extension for 3/8" line sizes or a 5/16" extension for large line sizes.
- 3 - Replace the stem cap. Tighten finger tight, then tighten an additional 1/6 turn.

To Close Service Valve:

- 1 - Remove the stem cap with an adjustable wrench.
- 2 - Using the adjustable wrench to keep the valve stationary, use a service wrench with a hex-head extension to turn the stem clockwise to seat the valve. Tighten the stem firmly.

NOTE - Use a 3/16" hex head extension for 3/8" line sizes or a 5/16" extension for large line sizes.

- 3 - Replace the stem cap. Tighten finger tight, then tighten an additional 1/6 turn.

NOTE - Stem cap must be replaced to help prevent valve leakage.

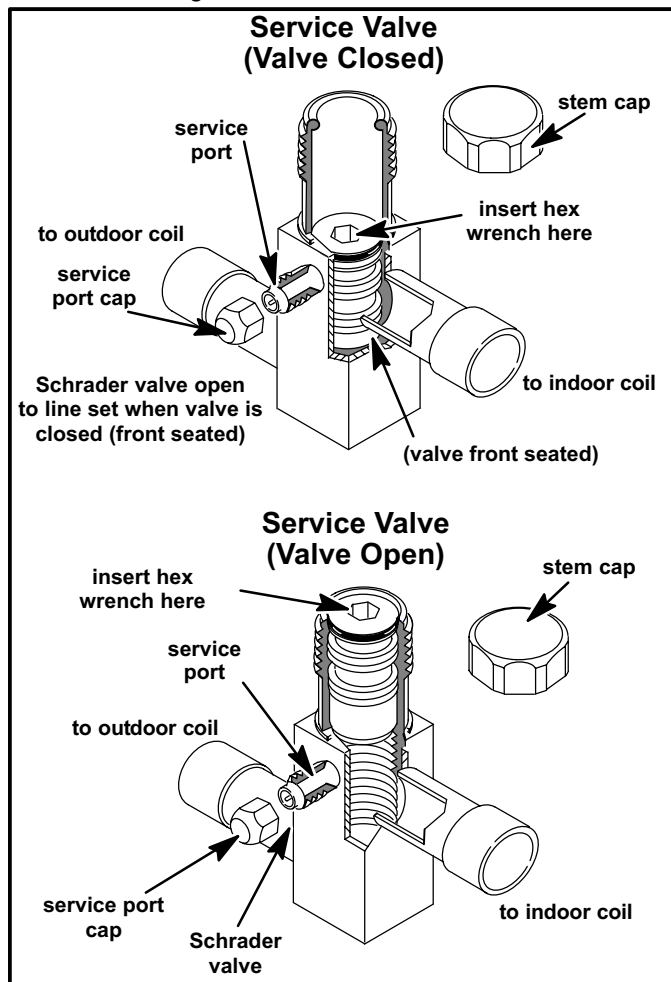

FIGURE 10

Vapor Line Ball Valve – 5 Ton Units Only

Vapor line service valves function the same way as the other valves, the difference is in the construction. A ball valve is illustrated in figure 11.

The ball valve is equipped with a service port with a factory-installed Schrader valve. A service port cap protects the Schrader valve from contamination and assures a leak-free seal.

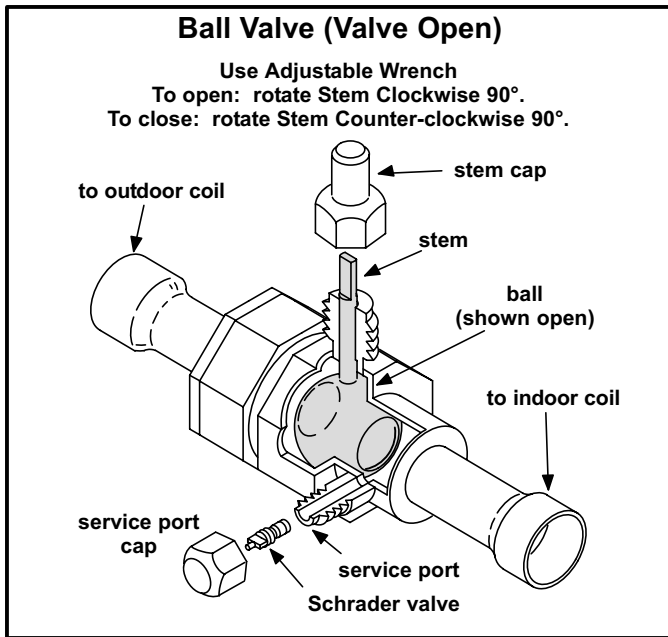

FIGURE 11

IV - CHARGING

⚠ WARNING

R-22 refrigerant can be harmful if it is inhaled. R-22 refrigerant must be used and recovered responsibly.

Failure to follow this warning may result in personal injury or death.

A - Leak Testing

After the line set has been connected to the indoor and outdoor units, check the line set connections and indoor unit for leaks.

⚠ IMPORTANT

The Clean Air Act of 1990 bans the intentional venting of (CFC's and HFC's) as of July 1, 1992. Approved methods of recovery, recycling or reclaiming must be followed. Fines and/or incarceration may be levied for noncompliance.

⚠ WARNING



Fire, Explosion and Personal Safety Hazard.

Failure to follow this warning could result in damage, personal injury or death.

Never use oxygen to pressurize or purge refrigeration lines. Oxygen, when exposed to a spark or open flame, can cause damage by fire and / or an explosion, that can result in personal injury or death.

⚠ WARNING



Danger of explosion!

When using a high pressure gas such as dry nitrogen to pressurize a refrigerant or air conditioning system, use a regulator that can control the pressure down to 1 or 2 psig (6.9 to 13.8 kPa).

Using an Electronic Leak Detector

- 1 - Connect a cylinder of R-22 to the center port of the manifold gauge set. Connect manifold gauge to service valve port.
- 2 - With both manifold valves closed, open the valve on the R-22 cylinder.
- 3 - Open the high pressure side of the manifold to allow the R-22 into the line set and indoor unit. Weigh in a trace amount of R-22. [A trace amount is a maximum of 2 ounces (57 g) or 3 pounds (31 kPa) pressure.] Close the valve on the R-22 cylinder and the valve on the high pressure side of the manifold gauge set. Disconnect the R-22 cylinder.
- 4 - Connect a cylinder of nitrogen with a pressure regulating valve to the center port of the manifold gauge set.
- 5 - Connect the manifold gauge set high pressure hose to the vapor valve service port. (Normally, the high pressure hose is connected to the liquid line port; however, connecting it to the vapor port better protects the manifold gauge set from high pressure damage.)
- 6 - Adjust the nitrogen pressure to 150 psig (1034 kPa). Open the valve on the high side of the manifold gauge set which will pressurize line set and indoor unit.
- 7 - After a few minutes, open a refrigerant port to ensure the refrigerant you added is adequate to be detected. (Amounts of refrigerant will vary with line lengths.) Check all joints for leaks. Purge nitrogen and R-22 mixture. Correct any leaks and recheck.

B - Evacuating

Evacuating the system of noncondensables is critical for proper operation of the unit. Noncondensables are defined as any gas that will not condense under temperatures and pressures present during operation of an air conditioning system. Noncondensables and water vapor combine with refrigerant to produce substances that corrode copper piping and compressor parts.

NOTE - This evacuation process is adequate for a new installation with clean and dry lines. If excessive moisture is present, the evacuation process may be required more than once.

⚠ IMPORTANT

Use a thermocouple or thermistor electronic vacuum gauge that is calibrated in microns. Use an instrument that reads from 50 microns to at least 10,000 microns.

- 1 - Connect manifold gauge set to the service valve ports :
 - low pressure gauge to *vapor* line service valve
 - high pressure gauge to *liquid* line service valve
- 2 - Connect micron gauge.
- 3 - Connect the vacuum pump (with vacuum gauge) to the center port of the manifold gauge set.
- 4 - Open both manifold valves and start the vacuum pump.
- 5 - Evacuate the line set and indoor unit to an **absolute pressure** of 23,000 microns (29.01 inches of mercury). During the early stages of evacuation, it is desirable to close the manifold gauge valve at least once to determine if there is a rapid rise in **absolute pressure**. A rapid rise in pressure indicates a relatively large leak. If this occurs, repeat the leak testing procedure.

*NOTE - The term **absolute pressure** means the total actual pressure within a given volume or system, above the absolute zero of pressure. Absolute pressure in a vacuum is equal to atmospheric pressure minus vacuum pressure.*
- 6 - When the absolute pressure reaches 23,000 microns (29.01 inches of mercury), close the manifold gauge valves, turn off the vacuum pump and disconnect the manifold gauge center port hose from vacuum pump. Attach the manifold center port hose to a nitrogen cylinder with pressure regulator set to 150 psig (1034 kPa) and purge the air from the hose with nitrogen. Open the manifold gauge valves to break the vacuum in the line set and indoor unit. Close the manifold gauge valves.



CAUTION

Danger of Equipment Damage.

Avoid deep vacuum operation. Do not use compressors to evacuate a system.

Extremely low vacuums can cause internal arcing and compressor failure.

Damage caused by deep vacuum operation will void warranty.

- 7 - Shut off the nitrogen cylinder and remove the manifold gauge hose from the cylinder. Open the manifold gauge valves to release the nitrogen from the line set and indoor unit.
- 8 - Reconnect the manifold gauge to the vacuum pump, turn the pump on, and continue to evacuate the line set and indoor unit until the absolute pressure does not rise above 500 microns (29.9 inches of mercury) within a 20-minute period after shutting off the vacuum pump and closing the manifold gauge valves.
- 9 - When the absolute pressure requirement above has been met, disconnect the manifold hose from the vacuum pump and connect it to an upright cylinder of R-22 refrigerant. Open the manifold gauge valves to break the vacuum from 1 to 2 psig positive pressure in the line set and indoor unit. Close manifold gauge valves and shut off the R-22 cylinder and remove the manifold gauge set.

C - Charging

Units are factory-charged with the amount of R-22 refrigerant indicated on the unit nameplate. This charge is based on a matching indoor coil and outdoor coil with 15 ft. (4.6 m) of line set. For varying lengths of line set, refer to table 3 on page 12 for refrigerant charge adjustment.

Check Indoor Airflow before Charging

NOTE - Be sure that filters and indoor and outdoor coils are clean before testing.

Check indoor airflow using the step procedures as illustrated in figure 12.

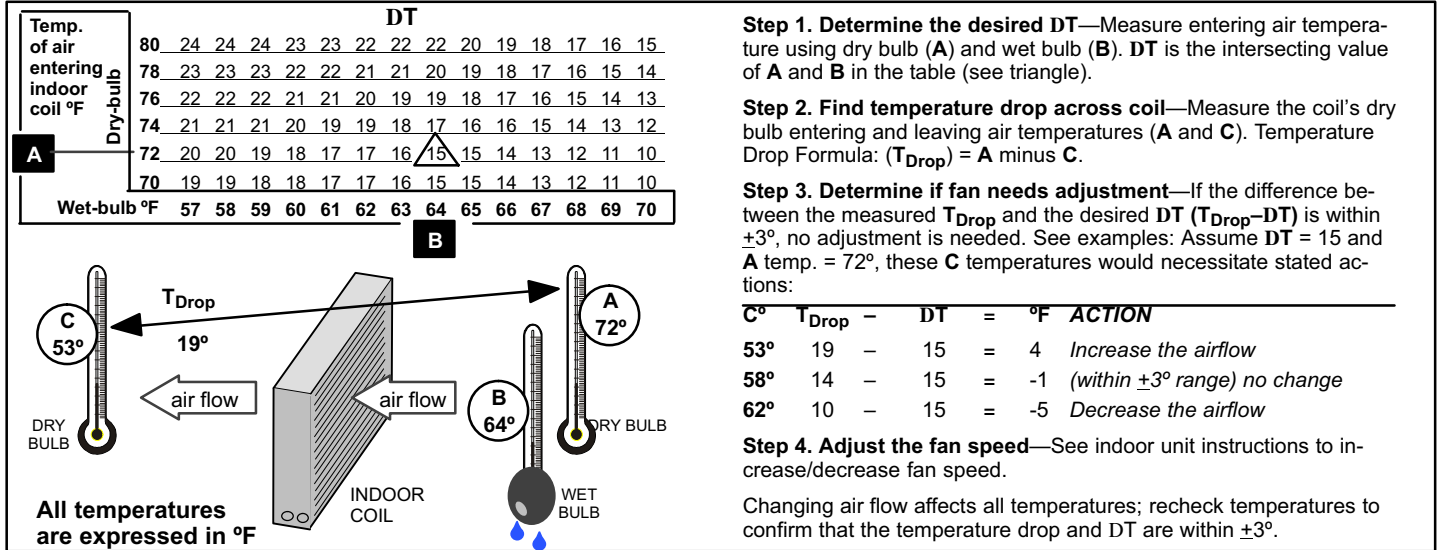

Step 1. Determine the desired DT—Measure entering air temperature using dry bulb (**A**) and wet bulb (**B**). **DT** is the intersecting value of **A** and **B** in the table (see triangle).

Step 2. Find temperature drop across coil—Measure the coil's dry bulb entering and leaving air temperatures (**A** and **C**). Temperature Drop Formula: (**T_{Drop}**) = **A** minus **C**.

Step 3. Determine if fan needs adjustment—If the difference between the measured **T_{Drop}** and the desired **DT** (**T_{Drop}**–**DT**) is within $\pm 3^\circ$, no adjustment is needed. See examples: Assume **DT** = 15 and **A** temp. = 72°, these **C** temperatures would necessitate stated actions:

C°	T _{Drop}	–	DT	=	°F	ACTION
53°	19	–	15	=	4	Increase the airflow
58°	14	–	15	=	-1	(within $\pm 3^\circ$ range) no change
62°	10	–	15	=	-5	Decrease the airflow

Step 4. Adjust the fan speed—See indoor unit instructions to increase/decrease fan speed.

Changing air flow affects all temperatures; recheck temperatures to confirm that the temperature drop and DT are within $\pm 3^\circ$.

FIGURE 12

Pre-Charge Maintenance Checks

TABLE 2
Normal Operating Pressures

▲ IMPORTANT

Use this table to perform maintenance checks; it is not a procedure for charging the system. Minor variations in these pressures may be due to differences in installations. Significant deviations could mean that the system is not properly charged or that a problem exists with some component in the system.

AC13	-018	-024	-030	-036	-042	-048-1 to -3	-048-4 and later	-060
°F (°C) * Normal Operating Pressures In psig (liquid +/- 10 and vapor +/- 5 PSIG)*								
Expansion Valve (TXV)								
65 (18)	141 / 80	147 / 79	141 / 76	145 / 74	143 / 78	145 / 80	140 / 77	151 / 76
70 (21)	154 / 81	159 / 79	154 / 76	157 / 75	153 / 79	157 / 81	152 / 77	164 / 77
75 (24)	166 / 81	173 / 80	167 / 77	170 / 76	167 / 80	170 / 81	165 / 77	177 / 78
80 (27)	180 / 82	187 / 81	181 / 78	186 / 76	182 / 80	184 / 82	179 / 78	192 / 78
85 (29)	195 / 82	218 / 82	195 / 78	201 / 77	198 / 81	198 / 82	192 / 78	207 / 79
90 (32)	209 / 83	202 / 81	210 / 79	217 / 77	215 / 81	214 / 83	209 / 80	223 / 80
95 (35)	222 / 83	234 / 82	227 / 80	234 / 78	231 / 82	230 / 84	227 / 81	240 / 80
100 (38)	244 / 84	251 / 83	249 / 81	251 / 79	249 / 83	247 / 84	243 / 81	259 / 81
105 (41)	258 / 85	267 / 84	260 / 81	268 / 79	268 / 84	265 / 85	261 / 82	277 / 81
110 (43)	276 / 85	287 / 84	278 / 82	288 / 80	287 / 84	283 / 85	279 / 83	297 / 82
115 (45)	294 / 86	307 / 85	299 / 83	309 / 81	308 / 85	303 / 86	296 / 83	318 / 83
Fixed Orifice (RFC)								
65 (18)	144 / 73	147 / 68	140 / 66	150 / 67	147 / 70	145 / 70	143 / 77	150 / 67
70 (21)	157 / 76	160 / 71	152 / 68	162 / 70	158 / 72	156 / 72	154 / 72	163 / 70
75 (24)	167 / 78	173 / 74	166 / 71	176 / 72	171 / 75	170 / 75	167 / 78	177 / 72
80 (27)	182 / 80	189 / 77	180 / 74	190 / 74	184 / 77	183 / 78	180 / 79	191 / 75
85 (29)	196 / 82	203 / 79	196 / 76	205 / 76	198 / 78	198 / 80	193 / 81	207 / 77
90 (32)	211 / 84	219 / 81	211 / 79	220 / 78	213 / 80	213 / 82	207 / 82	221 / 79
95 (35)	225 / 84	238 / 83	227 / 80	237 / 79	228 / 81	230 / 84	221 / 84	239 / 80
100 (38)	242 / 86	255 / 85	294 / 82	255 / 80	245 / 82	246 / 85	237 / 85	256 / 81
105 (41)	256 / 86	272 / 86	262 / 83	273 / 81	262 / 84	264 / 86	253 / 86	274 / 83
110 (43)	278 / 88	294 / 87	282 / 84	291 / 83	281 / 84	282 / 87	269 / 87	295 / 84
115 (45)	293 / 88	317 / 88	302 / 86	314 / 84	300 / 85	301 / 88	289 / 88	315 / 85

*Temperature of the air entering the outside coil.

**Typical pressures; indoor unit match up, indoor air quality equipment, and indoor load causes pressure variance

Determining Charge Method

START: Determine how refrigerant is metered

WHEN TO CHARGE?

- Warm weather best
- Can charge in colder weather

CHARGE METHOD? Determine by:

- Metering device type
- Outdoor ambient temperature

REQUIREMENTS:

- Sufficient heat load in structure
- Indoor temperature between 70-80°F (21-26°C)
- Manifold gauge set connected to unit
- Thermometers:
 - to measure outdoor ambient temperature
 - to measure liquid line temperature
 - to measure vapor line temperature

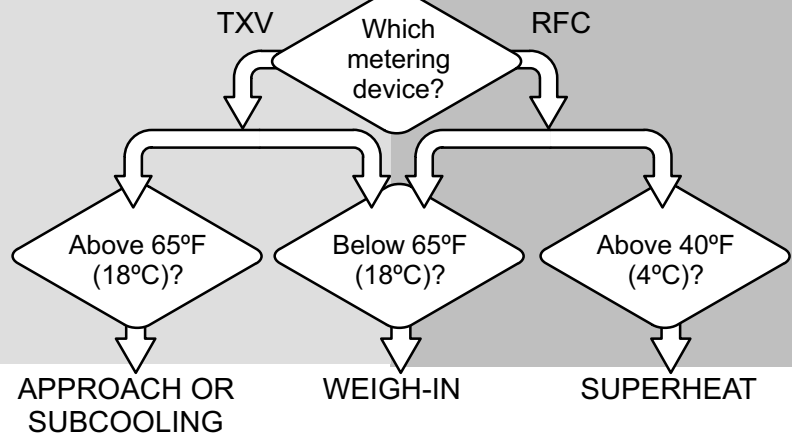

FIGURE 13

Weigh in Charge

1. Confirm proper airflow across coil per instructions as illustrated in figure 12 on page 10.
2. Check Liquid and Vapor line pressures and compare with Normal Operating Pressures listed in table 2 on page 11.

NOTE - Table 2 on page 11 is a general guide. Expect minor pressures variations. Significant differences may mean improper charge or other system problem.)

3. Recover the refrigerant from the unit.
4. Conduct leak check; evacuate as previously outlined.

5. Weigh in the unit nameplate charge plus any charge required for linesets differences from 15 feet and any extra indoor unit match-up amount. If weighing facilities are not available, use either Superheat or TXV subcooling method.

Table 3
Refrigerant Charge per Line Set Lengths

Liquid Line Set Diameter	Ounces per 5 feet (g per 1.5 m) adjust from 15 feet (4.6 m) line set*
3/8 in. (9.5 mm)	3 ounce per 5 ft. (85 g per 1.5 m)

*NOTE - *If line length is greater than 15 ft. (4.6 m), add this amount. If line length is less than 15 ft. (4.6 m), subtract this amount.*

Superheat RFC Charge

START: Measure outdoor ambient temperature

USE WEIGH-IN METHOD

Weigh-in or remove refrigerant based upon line length

BELOW

ABOVE

Outdoor ambient 40°F (4°C)?

- 1.. Confirm proper airflow across coil using figure 12 on page 10.
- 2.. Check liquid and vapor line pressures and compare unit pressures with Normal Operating Pressures listed in table 2 on page 11.
(Note: Table 2 is a general guide. Expect minor pressures variations. Significant differences may mean improper charge or other system problem.)
- 3.. Use SUPERHEAT to correctly charge unit or to verify the charge is correct.

SUPERHEAT RFC

If refrigerant added or removed, retest to confirm that unit is properly charged

If value is greater than shown, add refrigerant; if less than shown, remove refrigerant.

SH° (Superheat) Values (+/-5°F)

°F*	Wet Bulb (air entering indoor coil)													
	50	52	54	56	58	60	62	64	66	68	70	72	74	76
40	15	18	20	23	26	29	32	34	38	41	43	46	48	51
45	13	16	18	21	24	27	30	33	36	39	41	44	46	49
50	11	14	16	19	22	25	28	31	34	37	39	42	44	47
55	9	12	14	17	20	23	27	30	33	36	38	40	42	44
60	7	10	12	15	18	21	24	27	30	33	35	38	40	43
65	-	6	10	13	16	19	21	24	27	30	33	36	38	41
70	-	-	7	10	13	16	19	21	24	27	30	33	36	39
75	-	-	-	6	9	12	15	18	21	24	28	31	34	37
80	-	-	-	-	5	8	12	15	18	21	25	28	31	35
85	-	-	-	-	-	-	8	11	15	19	22	26	30	33
90	-	-	-	-	-	-	5	9	13	16	20	24	27	31
95	-	-	-	-	-	-	-	6	10	14	18	22	25	29
100	-	-	-	-	-	-	-	-	8	12	16	21	24	28
105	-	-	-	-	-	-	-	-	5	9	13	17	22	26
110	-	-	-	-	-	-	-	-	-	6	11	15	20	25
115	-	-	-	-	-	-	-	-	-	-	8	14	18	24

* Dry-bulb temperature (°F) of entering outdoor ambient air.

NOTE - Do not attempt to charge system where a dash appears, system could be overcharged. Superheat is taken at vapor line service port. Vapor line superheat must never be less than 5°F at the vapor line service port.

SUPERHEAT METHOD

- 4.. Set thermostat to call for heat (must have a cooling load between 70-80°F (21-26°C))
- 5.. Connect gauge set
- 6.. When heat demand is satisfied, set thermostat to call for cooling
- 7.. Allow temperatures and pressures to stabilize
- 8.. Measure the vapor line pressure and use the use value to determine saturation temperature SAT° = _____
- 9.. Record vapor line temperature VAP° = _____
- 10.. Subtract to determine superheat (SH°):
- 11.. VAP° - SAT° = SH°
- 12.. Record the wet bulb temperature (air entering indoor coil) WB = _____
- 13.. Record outdoor ambient temperature
- 14.. Compare results with table to the left

Approach TXV Charge

START: Measure outdoor ambient temperature

USE WEIGH-IN METHOD

Weigh-in or remove refrigerant based upon line length

BELOW

ABOVE

Outdoor Ambient 65°F (18°C)?

- 1.. Confirm proper airflow across coil using figure 12 on page 10.
- 2.. Check liquid and vapor line pressures and compare unit pressures with Normal Operating Pressures listed in table 2 on page 11.
(Table 6 is a general guide. Expect minor pressures variations. Significant differences may mean improper charge or other system problem.)
- 3.. Use APPROACH to correctly charge unit or to verify the charge is correct.

APPROACH TXV

If value is greater than shown (high approach), add refrigerant; if less than shown (liquid temp too close to ambient temp, low approach), remove refrigerant.

If refrigerant added or removed, retest to confirm that unit is properly charged

APP° (Approach) Values(F: +/-1.0°; [C: +/-0.5°])

°F (°C)*	-018	-024	-030	-036	-042	-048	-048-4	-060
Any	6 (3.3)	10 (5.6)	11 (6.0)	9 (5.0)	6 (3.3)	5 (2.8)	6 (3.3)	8 (4.4)

*Temperature of air entering outdoor coil

APPROACH METHOD

- 4.. Set thermostat to call for heat (must have a cooling load between 70-80°F (21-26°C))
- 5.. Connect gauge set
- 6.. When heat demand is satisfied, set thermostat to call for cooling
- 7.. Allow temperatures and pressures to stabilize
- 8.. Record outdoor ambient temperature AMB° = _____
- 9.. Record line temp. LIQ° = _____
- 10.. Subtract to determine approach (APP°):
- 11.. LIQ° - AMB° = APP°
- 12.. Compare results with table to the left

Subcooling TXV Charge

START: Measure outdoor ambient temperature

USE WEIGH-IN METHOD
Weigh-in or remove refrigerant based upon line length

ABOVE
Below or
above 65°F
(18°C)?

BELOW

- 1.. Confirm proper airflow across coil using figure 12 on page 10.
- 2.. Check liquid and vapor line pressures and compare unit pressures with Normal Operating Pressures listed in table 2 on page 11. (Table 2 is a general guide. Expect minor pressures variations. Significant differences may mean improper charge or other system problem.)
- 3.. Use SUBCOOLING to correctly charge unit or to verify the charge is correct.

SUBCOOLING TXV

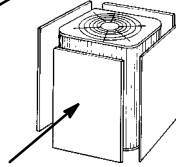

If refrigerant added or removed, verify charge using the approach method

If value is greater than shown, remove refrigerant; if less than shown, add refrigerant

BLOCK OUTDOOR COIL - Sometimes necessary with lower temperatures] Use cardboard or plastic sheet to restrict the airflow through the outdoor coil to achieve pressures from 200-250 psig . Higher pressures are needed to check charge. Block equal sections of air intake panels and move coverings sideways until the liquid pressure is in the above noted ranges.

SC° (Subcooling) Values (F: +/-1.0°; [C: +/-0.5°])

°F (°C)*	-018	-024	-030	-036	-042	-048	048-4	060
Any	7.5 (4.1)	8 (4.4)	4 (2.2)	7 (3.8)	10.1(5.6)	9.8 (5.4)	9 (5)	13.7 (7.6)

*Temperature of air entering outdoor coil

SUBCOOLING METHOD

- 4.. Set thermostat to call for heat (must have a cooling load between 70-80°F (21-26°C)
- 5.. Connect gauge set
- 6.. Measure outdoor ambient temperature
- 7.. When heat demand is satisfied, set thermostat to call for cooling
- 8.. Allow temperatures and pressures to stabilize [NOTE - IF NECESSARY, block outdoor coil to maintain 325 - 375 psig]
- 9.. Record line temp. LIQ° = _____
- 10.. Measure liquid line pressure and use the value to determine saturation temperature SAT° = _____
- 11.. Subtract to determine subcooling (SC°):
- 12.. SAT° _____ - LIQ° _____ = SC° _____
- 13.. Compare results with table to the left.

V - MAINTENANCE

WARNING



Electric shock hazard. Can cause injury or death. Before attempting to perform any service or maintenance, turn the electrical power to unit OFF at disconnect switch(es). Unit may have multiple power supplies.

At the beginning of each cooling season, the system should be serviced. In addition, the system should be cleaned as follows:

A - Outdoor Unit

- 1 - Clean and inspect the outdoor coil. The coil may be flushed with a water hose. Ensure the power is turned off before you clean the coil.
- 2 - Condenser fan motor is prelubricated and sealed. No further lubrication is needed.
- 3 - Visually inspect connecting lines and coils for evidence of oil leaks.
- 4 - Check wiring for loose connections.
- 5 - Check for correct voltage at unit (unit operating).
- 6 - Check amp-draw condenser fan motor.

Unit nameplate _____ Actual _____ .

NOTE - If owner complains of insufficient cooling, the unit should be gauged and refrigerant charge checked. Refer to section on refrigerant charging in this instruction.

B - Indoor Coil

- 1 - Clean coil, if necessary.
- 2 - Check connecting lines and coils for evidence of oil leaks.
- 3 - Check the condensate line and clean it if necessary.

C - Indoor Unit

- 1 - Clean or change filters.
- 2 - Adjust blower speed for cooling. Measure the pressure drop over the coil to determine the correct blower CFM. Refer to the unit information service manual for pressure drop tables and procedure.
- 3 - *Belt Drive Blowers* - Check belt for wear and proper tension.
- 4 - Check all wiring for loose connections
- 5 - Check for correct voltage at unit (blower operating).
- 6 - Check amp-draw on blower motor
Unit nameplate _____ Actual _____ .

VI - WIRING DIAGRAMS AND SEQUENCE OF OPERATION

AC13

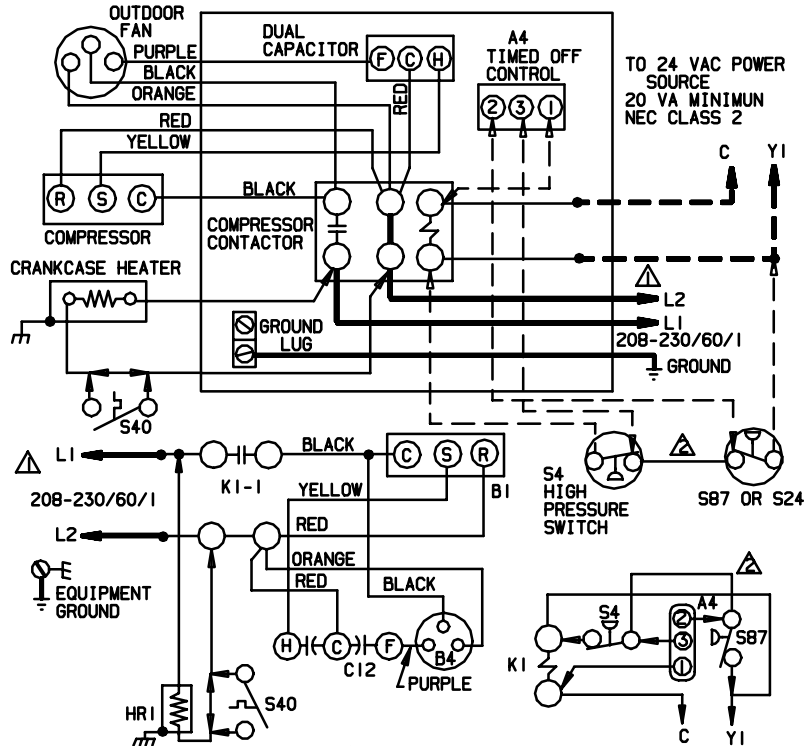

KEY	DESCRIPTION
A4	CONTROL-TIMED OFF
B1	COMPRESSOR
B4	MOTOR-OUTDOOR FAN
C12	CAPACITOR-DUAL
HR1	HEATER-COMPRESSOR
K1-1	CONTACTOR-COMPRESSOR
S4	SWITCH-HIGH PRESSURE
S24	SWITCH-LOSS OF CHARGE
S40	THERMOSTAT-CRANKCASE
S87	SWITCH-LOW PRESS. COMP I

▲ FOR USE WITH COPPER CONDUCTORS ONLY. REFER TO UNIT RATING PLATE FOR MINIMUM CIRCUIT AMPACITY AND MAXIMUM OVERCURRENT PROTECTION SIZE.

▲ JUMPER IS USED WHEN TOC IS NOT USED

TO 24 VAC POWER SOURCE
20 VA MINIMUM
NEC CLASS 2

WARNING-
ELECTRIC SHOCK HAZARD, CAN CAUSE INJURY OR DEATH. UNIT MUST BE GROUNDED IN ACCORDANCE WITH NATIONAL AND LOCAL CODES.

← INDICATES OPTIONAL COMPONENTS

———— LINE VOLTAGE FIELD INSTALLED
- - - - CLASS 11 VOLTAGE FIELD INSTALLED

09/05	Supersedes Form No.
	New Form No.
	534,773W

© 2005

Litho U.S.A.

NOTE- The thermostat used may be electromechanical or electronic.

NOTE- Transformer in indoor unit supplies power (24 VAC) to the thermostat and outdoor unit controls.

COOLING:

- 1- Cooling demand initiates at Y1 in the thermostat.
- 2- 24VAC from indoor unit (Y1) energizes the TOC timed off control (if used) which energizes contactor K1.
- 3- K1-1 N.O. closes, energizing compressor (B1) and outdoor fan motor (B4).
- 4- Compressor (B1) and outdoor fan motor (B4) begin immediate operation..

END OF COOLING DEMAND:

- 5- Cooling demand is satisfied. Terminal Y1 is de-energized and the TOC(if used) begins its off cycle timing.
- 6- Compressor contactor K1 is de-energized.
- 7- K1-1 opens and compressor (B1) and outdoor fan motor (B4) are de-energized and stop immediately.