

14ACX SERIES UNITS

The 14ACX is a high efficiency residential split-system condensing unit, which features a scroll compressor and designed for R-410A refrigerant. 14ACX units are available in sizes ranging from 1-1/2 through 5 tons. The series is designed for use with an expansion valve (TXV) or fixed orifice system (RFC) in the indoor unit. This manual is divided into sections which discuss the major components, refrigerant system, charging procedure, maintenance and operation sequence.

Information contained in this manual is intended for use by qualified service technicians only. All specifications are subject to change.

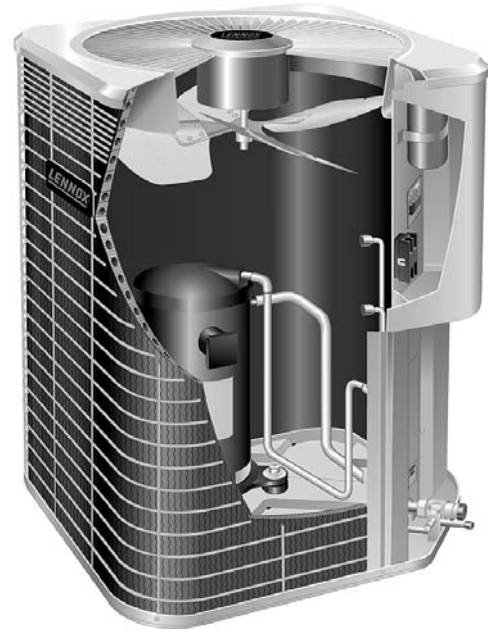

! IMPORTANT

Operating pressures of this R-410A unit are higher than pressures in R-22 units. Always use service equipment rated for R-410A.

! WARNING

Improper installation, adjustment, alteration, service or maintenance can cause property damage, personal injury or loss of life. Installation and service must be performed by a qualified installer or service agency.

! WARNING

Warranty will be voided if covered equipment is removed from original installation site. Warranty will not cover damage or defect resulting from: Flood, wind, lightning, or installation and operation in a corrosive atmosphere (chlorine, fluorine, salt, recycled waste water, urine, fertilizers, or other damaging chemicals).

TABLE OF CONTENTS

General Page 1
Specifications / Electrical Data Page 2
I Application Page 3
II Unit Components Page 3
III Refrigeration System Page 6
IV Charging Page 7
VI Maintenance Page 13
VII Wiring and Sequence of Operation . Page 14

SPECIFICATIONS

General Data		Model No. Nominal Tonnage	14ACX-018	14ACX-024	14ACX-030	14ACX-036	14ACX-042	14ACX-048	14ACX-060
			1.5	2	2.5	3	3.5	4	5
Connections (sweat)	Liquid line o.d. - in.		3/8	3/8	3/8	3/8	3/8	3/8	3/8
	Suction line o.d. - in.		3/4	3/4	3/4	7/8	7/8	7/8	1-1/8
¹ Refrigerant (R-410A) furnished			6 lbs. 12 oz.	7 lbs. 10 oz.	8 lbs. 0 oz.	8 lbs. 9 oz.	8 lbs. 10 oz.	10 lbs. 0 oz.	12 lbs. 0 oz.
Outdoor Coil	Net face area - sq. ft.	Outer coil	13.22	13.22	16.33	16.33	16.33	21.00	22.00
		Inner coil	12.60	12.60	15.71	15.71	15.71	20.25	21.33
	Tube diameter - in.		5/16	5/16	5/16	5/16	5/16	5/16	5/16
	Number of rows		2	2	2	2	2	2	2
	Fins per inch		22	22	22	22	22	22	22
Outdoor Fan	Diameter - in.		18	18	22	22	22	22	26
	Number of blades		4	4	4	4	4	4	4
	Motor hp		1/5	1/5	1/6	1/6	1/4	1/4	1/3
	Cfm		2400	2400	2900	2900	3500	3600	4400
	Rpm		1100	1100	825	825	825	825	825
	Watts		200	200	220	220	310	310	310
Shipping Data - lbs. 1 package			146	148	169	172	198	221	238

ELECTRICAL DATA

Line voltage data - 60 hz - 1ph		208/230V	208/230V	208/230V	208/230V	208/230V	208/230V	208/230V
² Maximum overcurrent protection (amps)		20	30	30	30	40	50	60
³ Minimum circuit ampacity		12.3	17.9	17.2	18.7	24.1	29.0	34.8
Compressor	Rated load amps	9.0	13.4	12.9	14.1	17.9	21.8	26.4
	Power factor	.96	.97	.98	.98	.94	.95	.98
	Locked rotor amps	48	58	64	77	112	117	134
Condenser Fan Motor	Full load amps	1.0	1.0	1.1	1.1	1.7	1.7	1.8
	Locked rotor amps	1.9	1.9	2.1	2.1	3.1	3.1	2.9

OPTIONAL ACcESSORIES - must be ordered extra

Compressor Crankcase Heater	93M05	•	•	•	•			
	93M06					•	Factory	Factory
Compressor Hard Start Kit	10J42	•						
	88M91		•	•	•	•	•	•
Compressor Low Ambient Cut-Off	45F08	•	•	•	•	•	•	•
Compressor Sound Cover	69J03	•	•	•	•	•	•	•
Compressor Time-Off Control	47J27	•	•	•	•	•	•	•
Freezestat	3/8 in. tubing	93G35	•	•	•	•	•	•
	5/8 in. tubing	50A93	•	•	•	•	•	•
Hail Guards	92M88	•	•					
	45M56			•	•	•		
	92M90						•	
	27W35							•
Loss of Charge Switch Kit	84M23	•	•	•	•	•	•	•
Low Ambient Kit	34M72	•	•	•	•	•	•	•
Mounting Base	69J06	•	•					
	69J07			•	•	•	•	•
Refrigerant Line Sets	L15-41-20, L15-41-30, L15-41-40, L15-41-50	•	•	•				
	L15-65-30, L15-65-40, L15-65-50				•	•	•	
	Field Fabricate							•
Time Delay Relay Kit	58M81	•	•	•	•	•	•	•
Unit Stand-Off Kit	94J45	•	•	•	•	•	•	•

NOTE — Extremes of operating range are plus 10% and minus 5% of line voltage.

¹ Refrigerant charge sufficient for 15 ft. length of refrigerant lines.

² HACR type circuit breaker or fuse.

³ Refer to National or Canadian Electrical Code manual to determine wire, fuse and disconnect size requirements.

I - APPLICATION

14ACX condensing units are available in 1-1/2, 2, 2 -1/2, 3, 3 -1/2, 4 and 5 ton capacities. All major components (indoor blower and coil) must be matched according to Lennox recommendations for the compressor to be covered under warranty. Refer to the Engineering Handbook for approved system matchups.

II - UNIT COMPONENTS

Unit components are illustrated in figure 1.

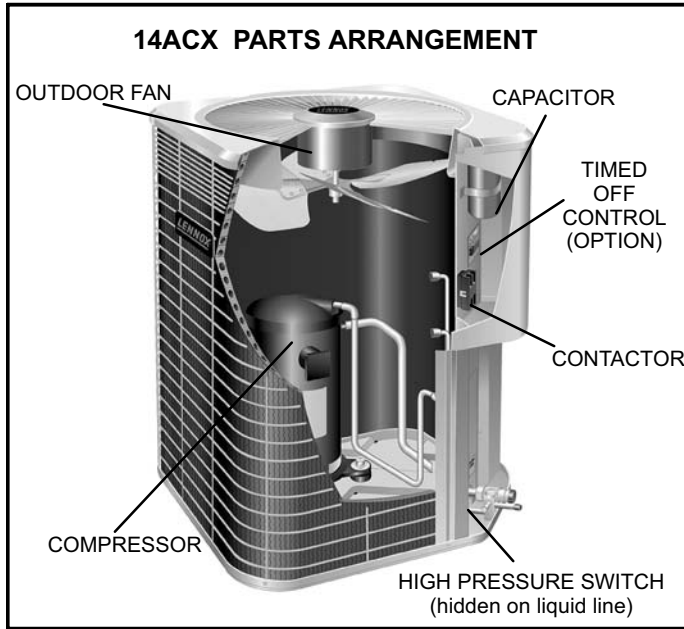

FIGURE 1

A - Control Box (Figure 2)

14ACX units are not equipped with a 24V transformer. All 24 VAC controls are powered by the indoor unit. Refer to wiring diagram.

Electrical openings are provided under the control box cover. Field thermostat wiring is made to color-coded pigtail connections.

ELECTROSTATIC DISCHARGE (ESD)

Precautions and Procedures

⚠ CAUTION

Electrostatic discharge can affect electronic components. Take precautions during unit installation and service to protect the unit's electronic controls. Precautions will help to avoid control exposure to electrostatic discharge by putting the unit, the control and the technician at the same electrostatic potential. Neutralize electrostatic charge by touching hand and all tools on an unpainted unit surface before performing any service procedure.

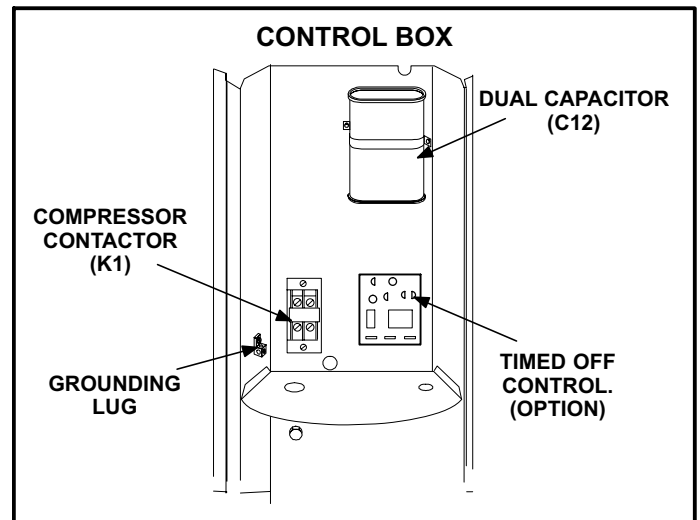

FIGURE 2

1 - Compressor Contactor K1

⚠ DANGER



Shock Hazard

Remove all power at disconnect before removing access panel. Single phase 14ACX units use single-pole contactors. Potential exists for electrical shock resulting in injury or death. Line voltage exists at all components (even when unit is not in operation).

The compressor is energized by a single-pole contactor located in the control box. See figure 2. K1 is energized by the indoor thermostat terminal Y1 (24V) when thermostat demand is present.

2 - Dual Capacitor C12

The compressor and fan in 14ACX series units use permanent split capacitor motors. The capacitor is located inside the unit control box (see figure 2). A single "dual" capacitor (C12) is used for both the fan motor and the compressor (see unit wiring diagram). The fan side and the compressor side of the capacitor have different MFD ratings. See side of capacitor for ratings.

3 - Timed Off Control TOC (option)

The time delay is electrically connected between thermostat terminal Y and the compressor contactor. Between cycles, the compressor contactor is delayed for 5 minutes \pm 2 minutes but may last as long as 8 minutes. At the end of the delay, the compressor is allowed to energize. When thermostat demand is satisfied, the time delay opens the circuit to the compressor contactor coil and the compressor is de-energized.

B - Compressor

The scroll compressor design is simple, efficient and requires few moving parts. A cutaway diagram of the scroll compressor is shown in figure 3. The scrolls are located in the top of the compressor can and the motor is located just below. The oil level is immediately below the motor.

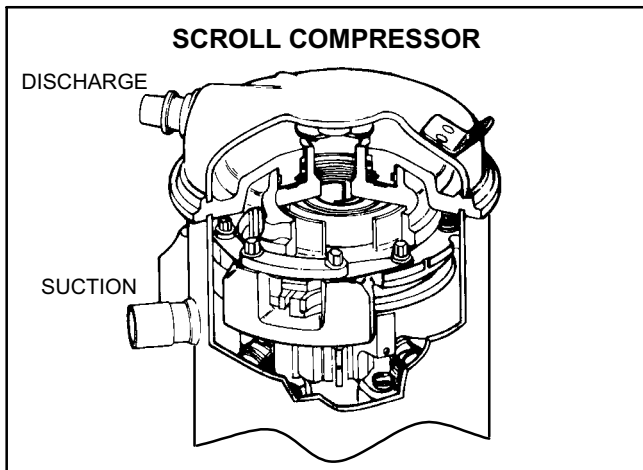

FIGURE 3

The scroll is a simple compression concept centered around the unique spiral shape of the scroll and its inherent properties. Figure 4 shows the basic scroll form. Two identical scrolls are mated together forming concentric spiral shapes (figure 5). One scroll remains stationary, while the other is allowed to "orbit" (figure 6). Note that the orbiting scroll does not rotate or turn but merely orbits the stationary scroll.

The counterclockwise orbiting scroll draws gas into the outer crescent shaped gas pocket created by the two scrolls (figure 6 - 1). The centrifugal action of the orbiting scroll seals off the flanks of the scrolls (figure 6 - 2). As the orbiting motion continues, the gas is forced toward the center of the scroll and the gas pocket becomes compressed (figure 6 - 3). When the compressed gas reaches the center, it is discharged vertically into a chamber and discharge port in the top of the compressor (figure 5). The discharge pressure forcing down on the top scroll helps seal off the upper and lower edges (tips) of the scrolls (figure 5). During a single orbit, several pockets of gas are compressed simultaneously providing smooth continuous compression.

The scroll compressor is tolerant to the effects of liquid return. If liquid enters the scrolls, the orbiting scroll is allowed to separate from the stationary scroll. The liquid is worked toward the center of the scroll and is discharged. If the compressor is replaced, conventional Lennox cleanup practices must be used.

Due to its efficiency, the scroll compressor is capable of drawing a much deeper vacuum than reciprocating compressors. Deep vacuum operation can cause internal fuse arcing resulting in damaged internal parts and will result in compressor failure. Never use a scroll compressor for evacuating or "pumping-down" the system. This type of damage can be detected and will result in denial of warranty claims.

The scroll compressor is quieter than a reciprocating compressor, however, the two compressors have much different sound characteristics. The sounds made by a scroll compressor do not affect system reliability, performance, or indicate damage.

NOTE - During operation, the head of a scroll compressor may be hot since it is in constant contact with discharge gas.

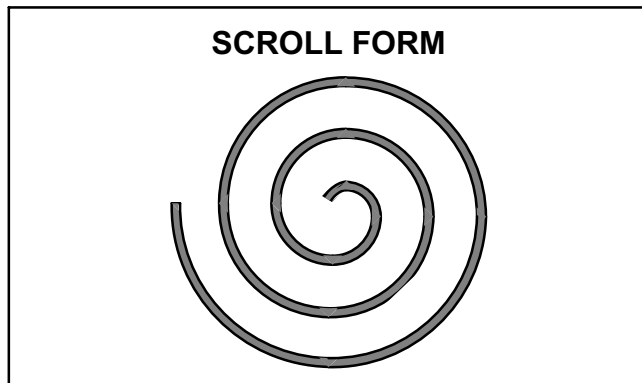

FIGURE 4

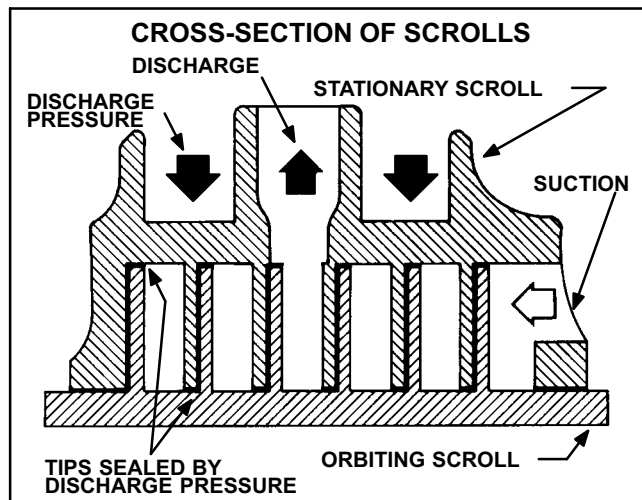

FIGURE 5

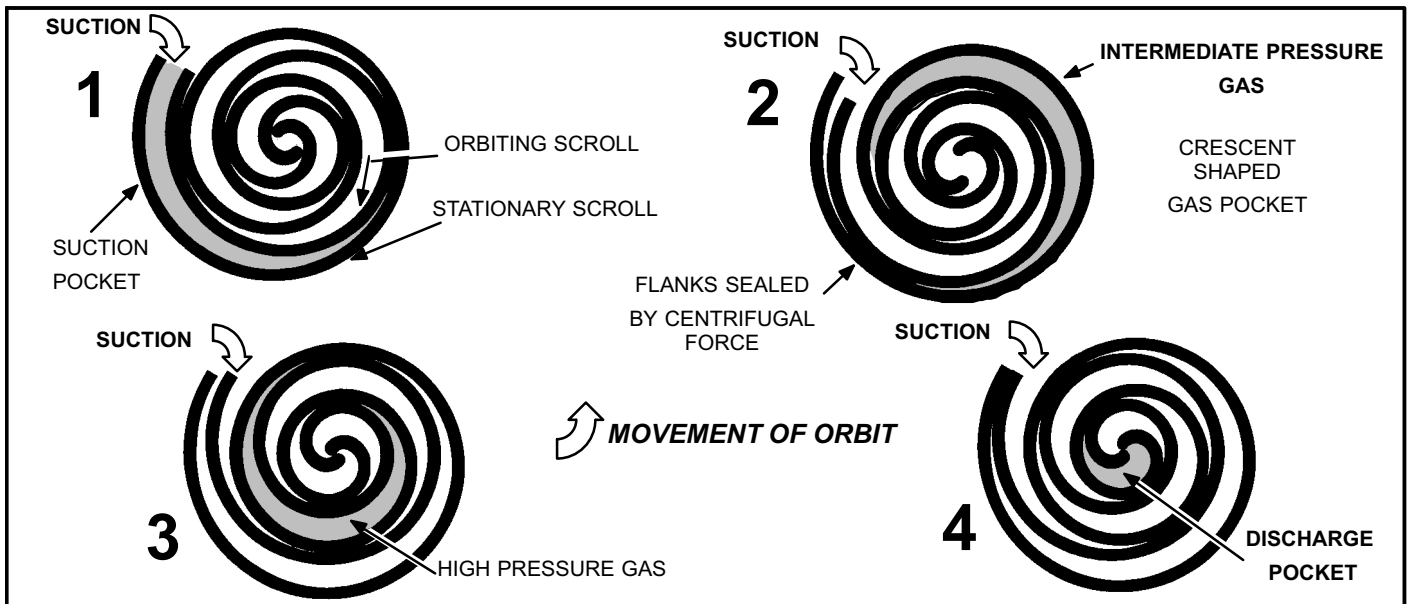

FIGURE 6

C - Condenser Fan Motor

All units use single-phase PSC fan motors which require a run capacitor. In all units, the condenser fan is controlled by the compressor contactor.

ELECTRICAL DATA tables in this manual show specifications for condenser fans used in 14ACX 's.

Access to the condenser fan motor on all units is gained by removing the seven screws securing the fan assembly. See figure 7. The condenser fan motor is removed from the fan guard by removing the four nuts found on the top panel. Drip loops (to prevent moisture from entering the motor) should be used in wiring when servicing motor. See figure 8 if condenser fan motor replacement is necessary.

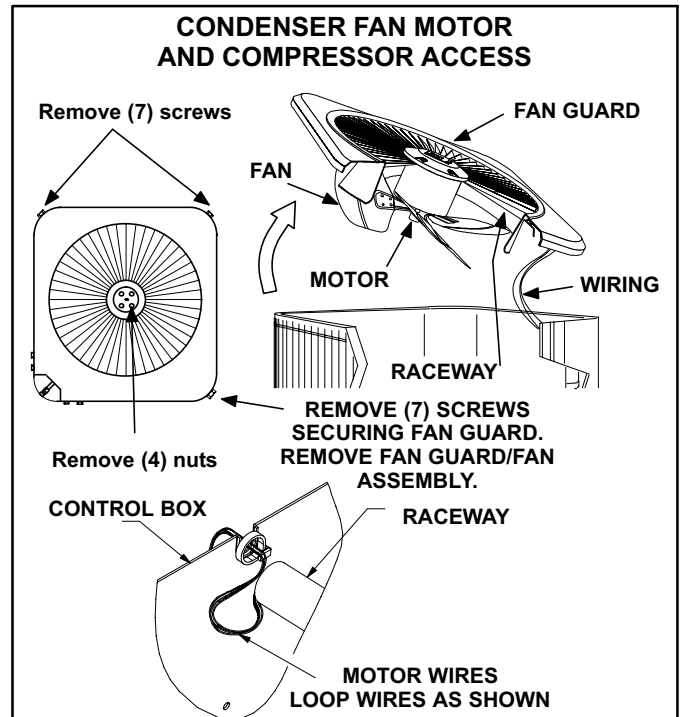

FIGURE 7

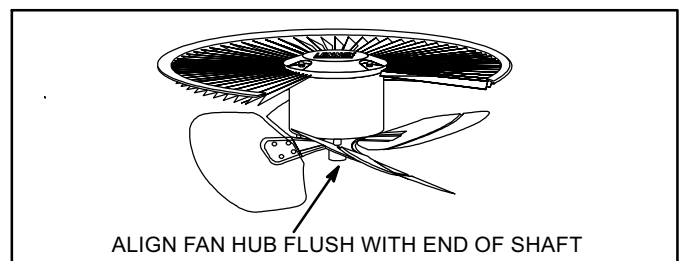

FIGURE 8

⚠ DANGER

Make sure all power is disconnected before beginning electrical service procedures.

D - Loss of Charge Switch (option)

An auto-reset, single-pole/single-throw low loss of charge switch is located in the suction line. This switch shuts off the compressor when suction pressure drops below the factory setting. The switch is closed during normal operating pressure conditions and is permanently adjusted to trip (open) at 25 ± 5 psi. The switch automatically resets when suction line pressure rises to 55 ± 5 psi.

rises to 55 ± 5 psig.

E - High Pressure Switch

14ACX units are equipped with a high pressure switch that is located in the liquid line. The switch (SPST, manual reset, normally closed) removes power from the compressor contactor control circuit when liquid line pressure rises above factory setting at 590 ± 10 psi.

F - Crankcase Heater (HR1) & Thermostat (S40) 4 and 5 ton only

14ACX-048 and -060 units are equipped with a 70 watt belly band type crankcase heater. HR1 prevents liquid from accumulating in the compressor. HR1 is controlled by S40 located on the liquid line. When liquid line temperature drops below 50° F S40 closes energizing HR1. S40 will open, de-energizing HR1 once liquid line temperature reaches 70° F.

G - Drier

A filter drier is factory provided and should be installed in the liquid line. The drier is designed to remove moisture, which can lead to compressor failure. **Any time the unit is exposed to air due to service, drier must be replaced. All replacement driers must be approved for R-410A refrigerant.**

III - REFRIGERANT SYSTEM

A - Plumbing

Field refrigerant piping consists of liquid and suction lines from the condensing unit (sweat connections) to the indoor evaporator coil (sweat connections). Use Lennox L15 (sweat) series line sets as shown in table 1.

TABLE 1

Unit	Liquid Line	Suction Line	L15 Line Sets
-018 -024 -030	3/8 in. (10 mm)	3/4 in. (19 mm)	L15-41 15 ft. - 50 ft. (4.6 m - 15 m)
-036 -042 -048	3/8 in. (10 mm)	7/8 in. (22 mm)	L15-65 15 ft. - 50 ft. (4.6 m - 15 m)
-060	3/8 in. (10 mm)	1-1/8 in. (29 mm)	Field Fabricated

The liquid line and vapor line service valves (figures 9 and 10) and gauge ports are accessible from the outside of the unit. Use the service ports for leak testing, evacuating, charging and checking charge.

Each valve is equipped with a service port which has a factory-installed Schrader valve. A service port cap protects the Schrader valve from contamination and serves as the primary leak seal. *Service valves are not rebuildable. If a valve has failed, you must replace it.*

IMPORTANT

Only use Allen wrenches of sufficient hardness (50Rc - Rockwell Hardness Scale min). Fully insert the wrench into the valve stem recess. Service valve stems are factory-torque (from 9 ft-lbs for small valves, to 25 ft-lbs for large valves) to prevent refrigerant loss during shipping and handling. Using an Allen wrench rated at less than 50Rc risks rounding or breaking off the wrench, or stripping the valve stem recess.

To Access Schrader Port:

- 1 - Remove service port cap with an adjustable wrench.
- 2 - Connect gauge to the service port.
- 3 - When testing is complete, replace service port cap. Tighten finger tight, then an additional 1/6 turn.

To Open Service Valve:

- 1 - Remove the stem cap with an adjustable wrench.
- 2 - Using the adjustable wrench to keep the valve stationary, use a service wrench with a hex-head extension to back the stem out counterclockwise as far as it will go.
NOTE - Use a 3/16" hex head extension for 3/8" line sizes or a 5/16" extension for large line sizes.
- 3 - Replace the stem cap. Tighten finger tight, then tighten an additional 1/6 turn.

To Close Service Valve:

- 1 - Remove the stem cap with an adjustable wrench.
- 2 - Using the adjustable wrench to keep the valve stationary, use a service wrench with a hex-head extension to turn the stem clockwise to seat the valve. Tighten the stem firmly.
NOTE - Use a 3/16" hex head extension for 3/8" line sizes or a 5/16" extension for large line sizes.
- 3 - Replace the stem cap. Tighten finger tight, then tighten an additional 1/6 turn.
NOTE - Stem cap must be replaced to help prevent valve leakage.

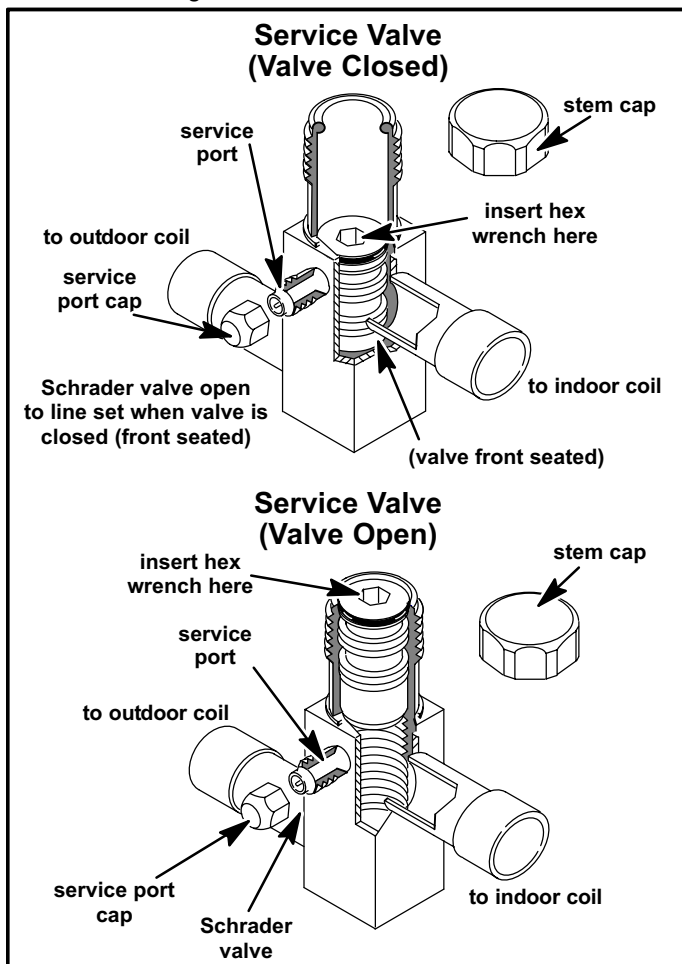

FIGURE 9

Vapor Line Ball Valve

Vapor line ball valves function the same way as the other valves, the difference is in the construction. A ball valve is illustrated in figure 10.

The ball valve is equipped with a service port with a factory-installed Schrader valve. A service port cap protects the Schrader valve from contamination and assures a leak-free seal.

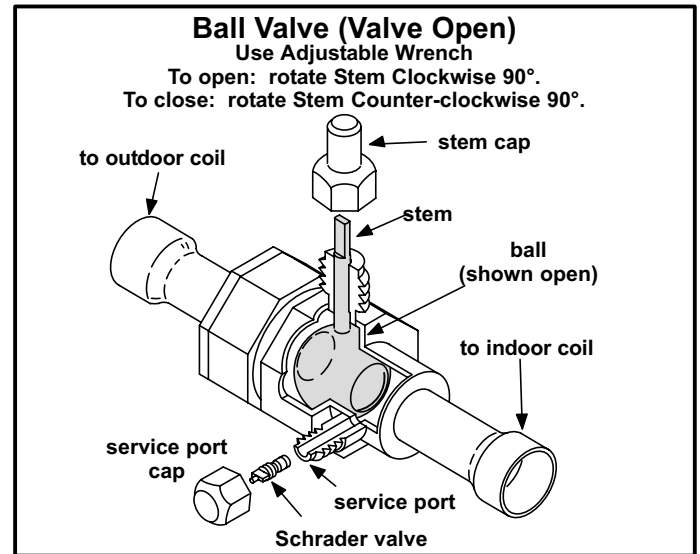

FIGURE 10

IV - CHARGING

⚠ WARNING

R-410A refrigerant can be harmful if it is inhaled. R-410A refrigerant must be used and recovered responsibly.

Failure to follow this warning may result in personal injury or death.

A - Leak Testing

After the line set has been connected to the indoor and outdoor units, check the line set connections and indoor unit for leaks.

⚠ IMPORTANT

The Clean Air Act of 1990 bans the intentional venting of (CFC's and HFC's) as of July 1, 1992. Approved methods of recovery, recycling or reclaiming must be followed. Fines and/or incarceration may be levied for noncompliance.

⚠ WARNING



Danger of explosion!

When using a high pressure gas such as dry nitrogen to pressurize a refrigerant or air conditioning system, use a regulator that can control the pressure down to 1 or 2 psig (6.9 to 13.8 kPa).

⚠ WARNING



Fire, Explosion and Personal Safety Hazard.

Failure to follow this warning could result in damage, personal injury or death.

Never use oxygen to pressurize or purge refrigeration lines. Oxygen, when exposed to a spark or open flame, can cause damage by fire and / or an explosion, that can result in personal injury or death.

Using an Electronic Leak Detector

- 1 - Connect a cylinder of R-410A to the center port of the manifold gauge set. Connect manifold gauge to service valve port.
- 2 - With both manifold valves closed, open the valve on the R-410A cylinder.
- 3 - Open the high pressure side of the manifold to allow the R-410A into the line set and indoor unit. Weigh in a trace amount of R-410A. [A trace amount is a maximum of 2 ounces (57 g) or 3 pounds (31 kPa) pressure.] Close the valve on the R-410A cylinder and the valve on the high pressure side of the manifold gauge set. Disconnect the R-410A cylinder.
- 4 - Connect a cylinder of nitrogen with a pressure regulating valve to the center port of the manifold gauge set.
- 5 - Connect the manifold gauge set high pressure hose to the vapor valve service port. (Normally, the high pressure hose is connected to the liquid line port; however, connecting it to the vapor port better protects the manifold gauge set from high pressure damage.)
- 6 - Adjust the nitrogen pressure to 150 psig (1034 kPa). Open the valve on the high side of the manifold gauge set which will pressurize line set and indoor unit.
- 7 - After a few minutes, open a refrigerant port to ensure the refrigerant you added is adequate to be detected. (Amounts of refrigerant will vary with line lengths.) Check all joints for leaks. Purge nitrogen and R-410A mixture. Correct any leaks and recheck.

B - Evacuating

Evacuating the system of noncondensables is critical for proper operation of the unit. Noncondensables are defined as any gas that will not condense under temperatures and pressures present during operation of an air conditioning system. Noncondensables and water vapor combine with refrigerant to produce substances that corrode copper piping and compressor parts.

NOTE - This evacuation process is adequate for a new installation with clean and dry lines. If excessive moisture is present, the evacuation process may be required more than once.

⚠ IMPORTANT

Use a thermocouple or thermistor electronic vacuum gauge that is calibrated in microns. Use an instrument that reads from 50 microns to at least 20,000 microns.

- 1 - Connect manifold gauge set to the service valve ports :
 - low pressure gauge to *vapor* line service valve
 - high pressure gauge to *liquid* line service valve
- 2 - Connect micron gauge.
- 3 - Connect the vacuum pump (with vacuum gauge) to the center port of the manifold gauge set.
- 4 - Open both manifold valves and start the vacuum pump.
- 5 - Evacuate the line set and indoor unit to an **absolute pressure** of 23,000 microns (29.01 inches of mercury). During the early stages of evacuation, it is desirable to close the manifold gauge valve at least once to determine if there is a rapid rise in **absolute pressure**. A rapid rise in pressure indicates a relatively large leak. If this occurs, repeat the leak testing procedure.

*NOTE - The term **absolute pressure** means the total actual pressure within a given volume or system, above the absolute zero of pressure. Absolute pressure in a vacuum is equal to atmospheric pressure minus vacuum pressure.*
- 6 - When the absolute pressure reaches 23,000 microns (29.01 inches of mercury), close the manifold gauge valves, turn off the vacuum pump and disconnect the manifold gauge center port hose from vacuum pump. Attach the manifold center port hose to a nitrogen cylinder with pressure regulator set to 150 psig (1034 kPa) and purge the air from the hose with nitrogen. Open the manifold gauge valves to break the vacuum in the line set and indoor unit. Close the manifold gauge valves.

⚠ CAUTION

Danger of Equipment Damage.
Avoid deep vacuum operation. Do not use compressors to evacuate a system.
Extremely low vacuums can cause internal arcing and compressor failure.
Damage caused by deep vacuum operation will void warranty.

- 7 - Shut off the nitrogen cylinder and remove the manifold gauge hose from the cylinder. Open the manifold gauge valves to release the nitrogen from the line set and indoor unit.
- 8 - Reconnect the manifold gauge to the vacuum pump, turn the pump on, and continue to evacuate the line set and indoor unit until the absolute pressure does not rise above 500 microns (29.9 inches of mercury) within a 20-minute period after shutting off the vacuum pump and closing the manifold gauge valves.
- 9 - When the absolute pressure requirement above has been met, disconnect the manifold hose from the vacuum pump and connect it to an upright cylinder of R-410A refrigerant. Open the manifold gauge valves to break the vacuum from 1 to 2 psig positive pressure in the line set and indoor unit. Close manifold gauge valves and shut off the R-410A cylinder and remove the manifold gauge set.

C - Charging

This system uses R-410A refrigerant which operates at much higher pressures than R-22. The provided liquid line filter drier is approved for use with R-410A. Do not replace it with components designed for use with R-22. This unit is NOT approved for use with coils which use capillary tubes as a refrigerant metering device.

Factory Charge

Units are factory-charged with the amount of R-410A refrigerant indicated on the unit rating plate. This charge is based on a matching indoor coil and outdoor coil with 15 ft. (4.6 m) line set. For varying lengths of line set, refer to table 2 for refrigerant charge adjustment.

TABLE 2

Refrigerant Charge per Line Set Lengths	
Liquid Line Set Diameter	Oz. per 5 ft. (g per 1.5 m) adjust from 15 ft. (4.6 m) line set*
3/8 in. (9.5 mm)	3 ounce per 5 ft. (85 g per 1.5 m)
NOTE - *If line length is greater than 15 ft. (4.6 m), add this amount. If line length is less than 15 ft. (4.6 m), subtract this amount.	

⚠ IMPORTANT

Mineral oils are not compatible with R-410A. If oil must be added, it must be a polyol ester oil.

NOTE - The compressor is charged with sufficient polyol ester oil. If oil must be added to the compressor in the field, use Mobil EAL™ Arctic 22CC or ICI EMKARATE™ RL32CF.

Pre-charge Airflow Check of Temperature Drop across Evaporator Coil (Delta-T)

NOTE - Be sure that filters and indoor and outdoor coils are clean before testing

Measure the entering air dry bulb (DB) and wet bulb (WB) temperatures at the indoor coil. Find Delta-T in table 3. Measure evaporator coil's leaving air DB and subtract that value from the entering air DB. The measured difference should be within + 3°F (1.8°C) of table value. If Delta-T is too low, decrease the indoor fan speed (refer to indoor unit for information). If the Delta-T is high, increase the indoor fan speed. Repeat charging procedure and Delta-T (air flow adjustment) procedure until both are correct.

Example:

Assume entering air DB - 72, WB - 64, leaving DB - 53. Delta-T should be 15 (per table); delta across coil is 19 (72 minus 53) which is 4°F higher than table value; therefore, increase fan speed.

Checking Charge

The outdoor unit should be charged during warm weather. However, applications arise in which charging must occur in the colder months. *The method of charging is determined by the unit's refrigerant metering device and the outdoor ambient temperature.*

TABLE 3

Dry bulb temperature of air entering indoor coil	80	24	24	24	23	23	22	22	22	20	19	18	17	16	15
	78	23	23	23	22	22	21	21	20	19	18	17	16	15	14
	76	22	22	22	21	21	20	19	19	18	17	16	15	14	13
	74	21	21	21	20	19	19	18	17	16	16	15	14	13	12
	72	20	20	19	18	17	17	16	15	15	14	13	12	11	10
	70	19	19	18	18	17	17	16	15	15	14	13	12	11	10
	57	58	59	60	61	62	63	64	65	66	67	68	69	70	
Wet bulb temperature of air entering indoor coil															

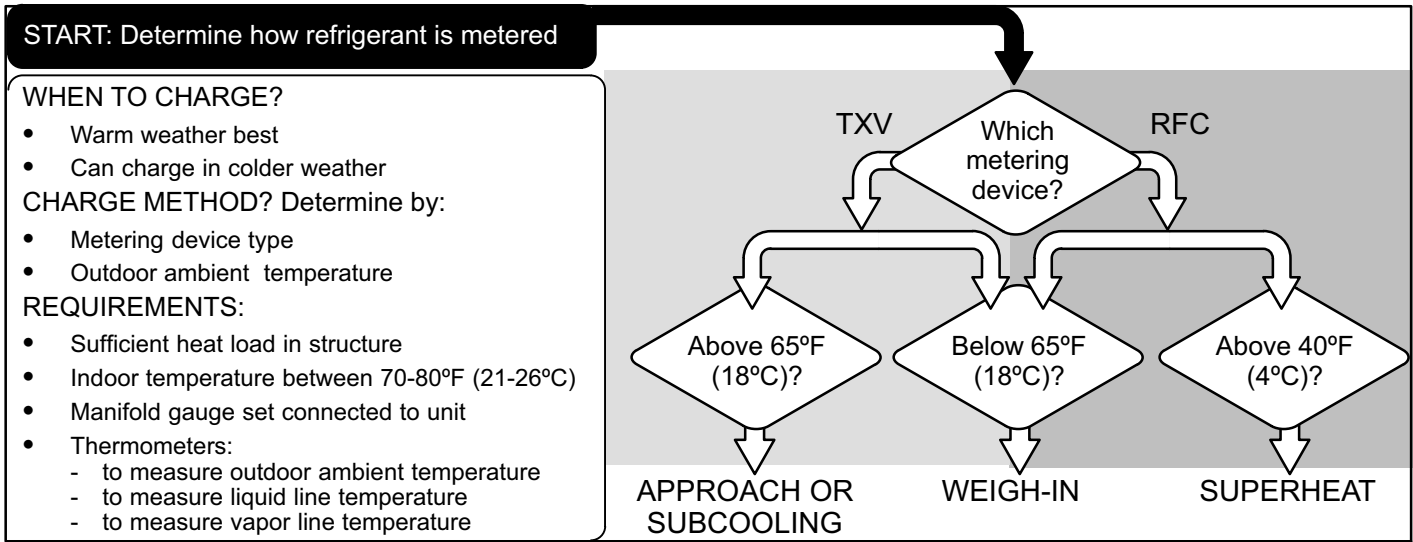

FIGURE 11. When to charge, method to use, conditions & equipment required

⚠ IMPORTANT Before attempting to charge any system, confirm proper airflow across the indoor coil. Airflow over the indoor coil can be determined by measuring the static pressure drop across the coil and comparing it with the factory table provided in the indoor coil installation instructions.

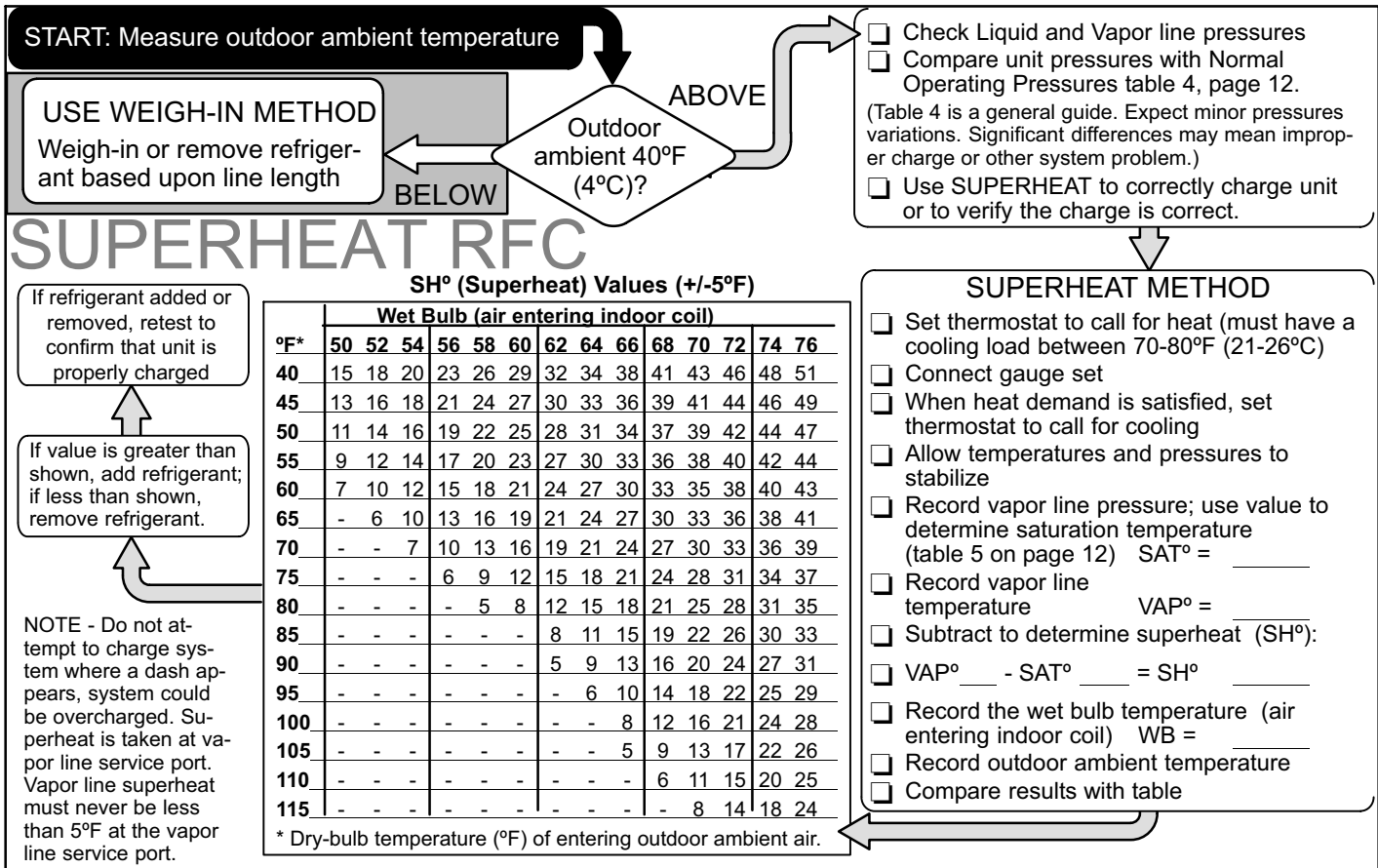

FIGURE 12. Charging RFC units with SUPERHEAT Method

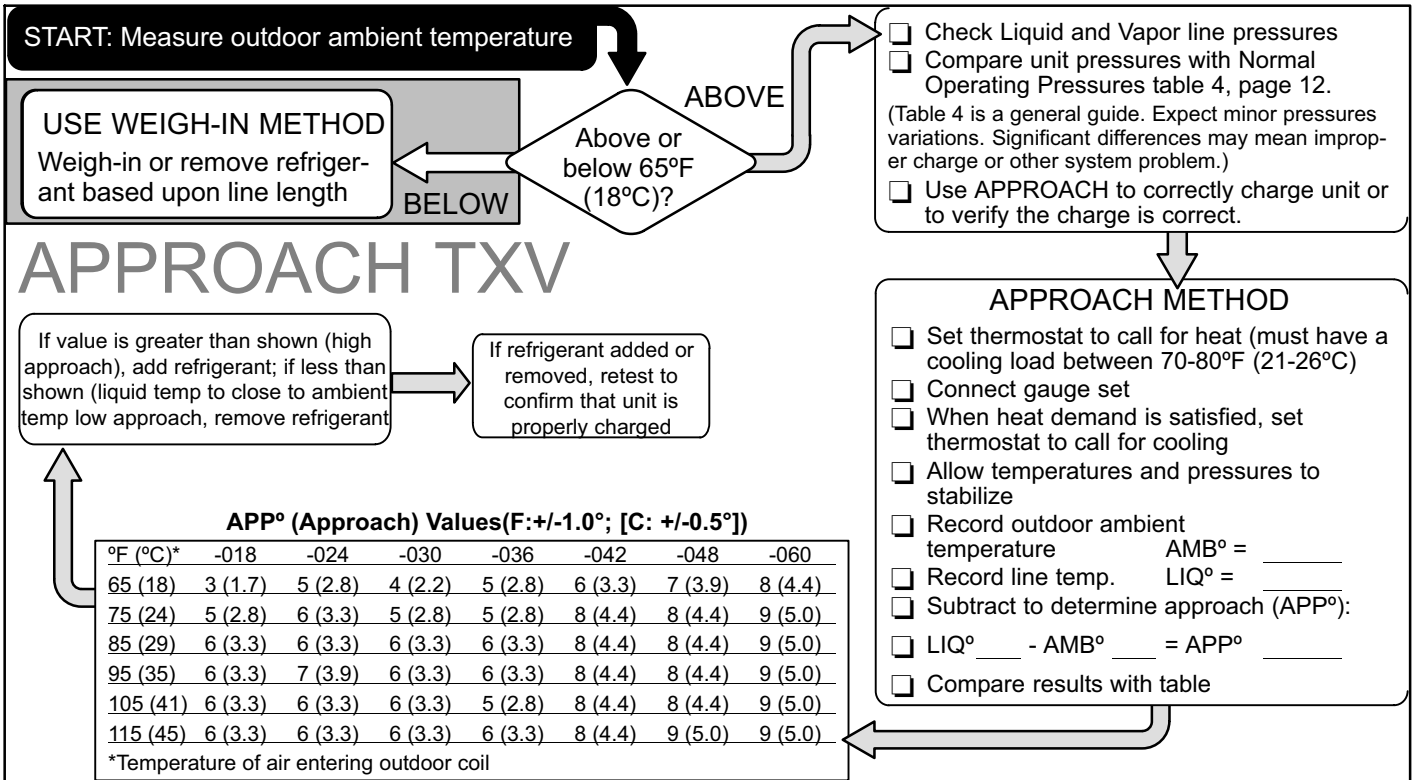

FIGURE 13 Charging TXV units with Approach Method

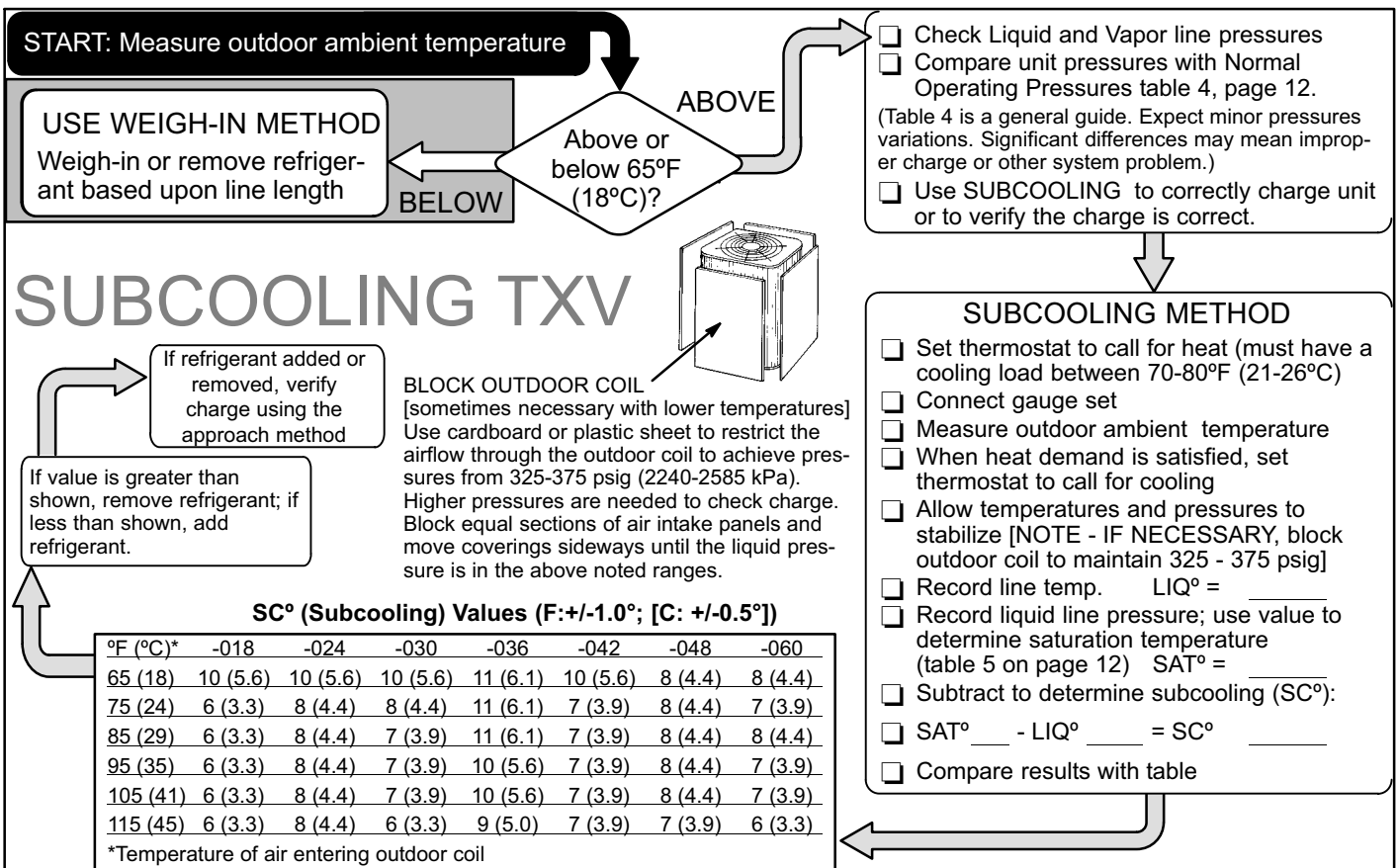

FIGURE 14 Charging TXV units with SUBCOOLING Method

TABLE 4
Normal Operating Pressures

⚠ IMPORTANT	Use this table to perform maintenance checks; it is not a procedure for charging the system. Minor variations in these pressures may be due to differences in installations. Significant deviations could mean that the system is not properly charged or that a problem exists with some component in the system.
--------------------	--

Model	-018	-024	-030	-036	-042	-048	-060
**Temp. °F (°C)	*Liquid Line Pressure / Vapor Line Pressure						
	Liquid / Vapor	Liquid / Vapor	Liquid / Vapor	Liquid / Vapor	Liquid / Vapor	Liquid / Vapor	Liquid / Vapor
Expansion Valve (TXV)							
65 (18)	222 / 140	233 / 138	230 / 136	240 / 137	236 / 138	238 / 136	239 / 133
70 (21)	241 / 141	250 / 138	247 / 137	259 / 138	253 / 140	256 / 138	258 / 135
75 (24)	259 / 143	271 / 140	265 / 139	278 / 139	273 / 141	277 / 139	278 / 136
80 (27)	279 / 144	291 / 141	287 / 140	299 / 139	296 / 142	299 / 140	300 / 137
85 (29)	301 / 145	313 / 143	308 / 141	321 / 140	318 / 143	320 / 139	323 / 138
90 (32)	319 / 145	335 / 143	331 / 142	344 / 141	341 / 144	343 / 140	346 / 139
95 (35)	346 / 146	361 / 145	355 / 144	368 / 142	366 / 146	369 / 141	370 / 140
100 (38)	370 / 147	384 / 146	380 / 145	393 / 143	392 / 147	395 / 142	396 / 142
105 (41)	396 / 148	412 / 147	405 / 146	419 / 144	417 / 148	422 / 144	415 / 143
110 (43)	422 / 150	436 / 148	432 / 147	446 / 145	445 / 149	450 / 146	449 / 145
115 (45)	451 / 151	468 / 149	461 / 148	477 / 146	475 / 151	481 / 148	476 / 147
Fixed Orifice (RFC)							
65 (18)	223 / 123	230 / 121	231 / 123	234 / 130	248 / 135	240 / 126	244 / 125
70 (21)	239 / 127	251 / 128	249 / 127	247 / 134	266 / 138	260 / 129	263 / 128
75 (24)	253 / 131	272 / 133	270 / 132	270 / 136	285 / 141	281 / 133	281 / 131
80 (27)	278 / 136	289 / 135	291 / 136	290 / 138	305 / 143	301 / 135	303 / 134
85 (29)	299 / 139	312 / 140	314 / 140	313 / 141	327 / 145	324 / 138	324 / 136
90 (32)	320 / 142	335 / 142	337 / 142	336 / 143	349 / 147	346 / 140	347 / 139
95 (35)	343 / 145	361 / 144	359 / 144	358 / 145	372 / 149	371 / 142	370 / 141
100 (38)	367 / 147	383 / 147	383 / 146	361 / 148	396 / 150	395 / 144	394 / 143
105 (41)	392 / 149	409 / 149	408 / 147	409 / 150	421 / 152	420 / 146	418 / 145
110 (43)	417 / 152	441 / 151	433 / 149	430 / 151	447 / 153	447 / 148	444 / 146
115 (46)	445 / 154	467 / 152	467 / 151	463 / 152	476 / 154	473 / 150	471 / 147

*Values shown are typical pressures; indoor unit match up, indoor air quality equipment, and indoor load will cause the pressures to vary.

**Temperature of the air entering the outside coil.

Table 5
HFC-410A Temperature (°F) - Pressure (Psig)

°F	Psig	°F	Psig	°F	Psig	°F	Psig	°F	Psig	°F	Psig	°F	Psig	°F	Psig
32	100.8	48	137.1	63	178.5	79	231.6	94	290.8	110	365.0	125	445.9	141	545.6
33	102.9	49	139.6	64	181.6	80	235.3	95	295.1	111	370.0	126	451.8	142	552.3
34	105.0	50	142.2	65	184.3	81	239.0	96	299.4	112	375.1	127	457.6	143	559.1
35	107.1	51	144.8	66	187.7	82	242.7	97	303.8	113	380.2	128	463.5	144	565.9
36	109.2	52	147.4	67	190.9	83	246.5	98	308.2	114	385.4	129	469.5	145	572.8
37	111.4	53	150.1	68	194.1	84	250.3	99	312.7	115	390.7	130	475.6	146	579.8
38	113.6	54	152.8	69	197.3	85	254.1	100	317.2	116	396.0	131	481.6	147	586.8
39	115.8	55	155.5	70	200.6	86	258.0	101	321.8	117	401.3	132	487.8	148	593.8
40	118.0	56	158.2	71	203.9	87	262.0	102	326.4	118	406.7	133	494.0	149	601.0
41	120.3	57	161.0	72	207.2	88	266.0	103	331.0	119	412.2	134	500.2	150	608.1
42	122.6	58	163.9	73	210.6	89	270.0	104	335.7	120	417.7	135	506.5	151	615.4
43	125.0	59	166.7	74	214.0	90	274.1	105	340.5	121	423.2	136	512.9	152	622.7
44	127.3	60	169.6	75	217.4	91	278.2	106	345.3	122	428.8	137	519.3	153	630.1
45	129.7	61	172.6	76	220.9	92	282.3	107	350.1	123	434.5	138	525.8	154	637.5
46	132.2	62	175.4	77	224.4	93	286.5	108	355.0	124	440.2	139	532.4	155	645.0
47	134.6			78	228.0			109	360.0			140	539.0		

V - MAINTENANCE

⚠ WARNING



Electric shock hazard. Can cause injury or death. Before attempting to perform any service or maintenance, turn the electrical power to unit OFF at disconnect switch(es). Unit may have multiple power supplies.

Maintenance and service must be performed by a qualified installer or service agency. At the beginning of each cooling season, the system should be checked as follows:

1. Make sure power is off before cleaning. Clean and inspect outdoor coil. The coil may be flushed with a water hose.

The outdoor coil is protected by an inner mesh screen and a wire cage (see figure 15). If debris has collected between the mesh screen and the coil and cannot be dislodged by spraying unpressurized water from inside coil surface to the outside, the mesh may be removed by first removing the top of the unit which will allow for removal of the wire cage.

Then, using pliers to grip the head of the push pins, pull straight out to extract the push pins along one side of the coil. If necessary, remove the push pins along the back of the unit; it is usually unnecessary to fully remove the inner mesh screen.

Drape the mesh screen back and wash the coil. When all the debris has been removed from the coil, reinstall the mesh screen by positioning it in its original position and reinserting the push pin. No tool is required to push the pin back into the same slot in the fins.

If the push pin is loose and tends not to stay in place, brush the fins with a fin brush (22 fins/in). Line up the push pin a couple fins to the right or left of the original hole and re-insert the pin.

2. Outdoor fan motor is prelubricated and sealed. No further lubrication is needed.
3. Visually inspect connecting lines and coils for evidence of oil leaks.
4. Check wiring for loose connections.

5. Check for correct voltage at unit (unit operating).

6. Check amp-draw outdoor fan motor.

Unit nameplate _____ Actual _____ .

NOTE - If owner reports insufficient cooling, the unit should be gauged and refrigerant charge checked. See refrigerant charging section.

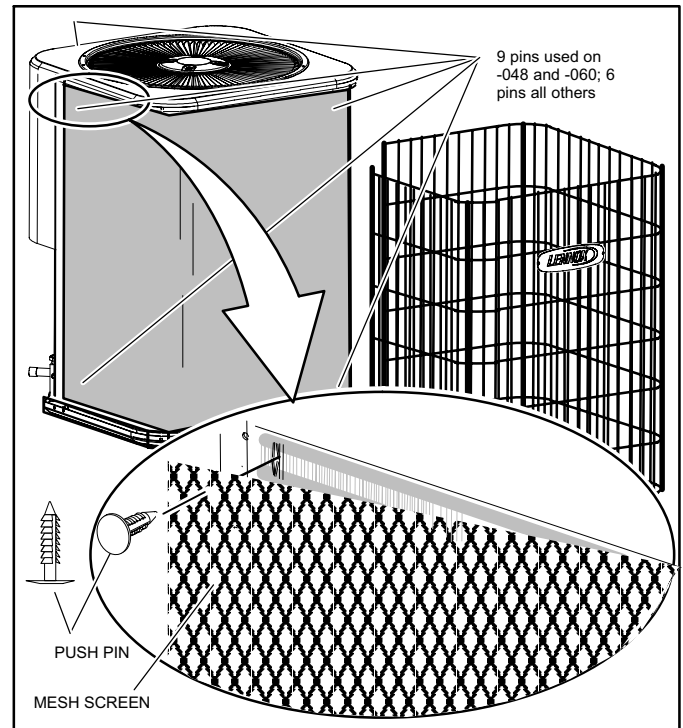

Figure 15

Indoor Coil

1. Clean coil, if necessary.
2. Check connecting lines and coils for signs of oil leaks.
3. Check the condensate pan line and clean if necessary.

Indoor Unit

1. Clean or change filters.
2. Adjust blower speed for cooling. The pressure drop over the coil should be measured to determine the correct blower CFM. Refer to the unit information service manual for pressure drop tables and procedure.
3. Check all wiring for loose connections
4. Check for correct voltage at unit (blower operating).
5. Check amp-draw on blower motor.

Unit nameplate _____ Actual _____ .

VI - 14ACX UNIT WIRING DIAGRAM AND SEQUENCE OF OPERATION

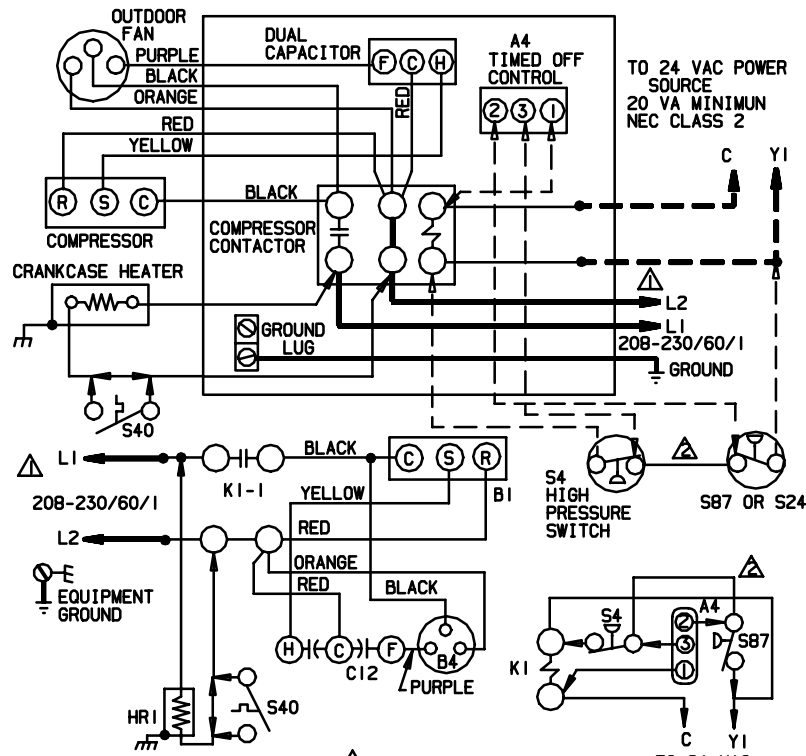

KEY	DESCRIPTION
	COMPONENT
A4	CONTROL-TIMED OFF
B1	COMPRESSOR
B4	MOTOR-OUTDOOR FAN
C12	CAPACITOR-DUAL
HR1	HEATER-COMPRESSOR
K1-1	CONTACTOR-COMPRESSOR
S4	SWITCH-HIGH PRESSURE
S24	SWITCH-LOSS OF CHARGE
S40	THERMOSTAT-CRANKCASE
S87	SWITCH-LOW PRESS. COMP I

▲ FOR USE WITH COPPER CONDUCTORS ONLY. REFER TO UNIT RATING PLATE FOR MINIMUM CIRCUIT AMPACITY AND MAXIMUM OVERCURRENT PROTECTION SIZE.

▲ JUMPER IS USED WHEN TOC IS NOT USED

TO 24 VAC POWER SOURCE
20 VA MINIMUM
NEC CLASS 2

WARNING-
ELECTRIC SHOCK HAZARD, CAN CAUSE INJURY OR DEATH. UNIT MUST BE GROUNDED IN ACCORDANCE WITH NATIONAL AND LOCAL CODES.

← INDICATES OPTIONAL COMPONENTS

———— LINE VOLTAGE FIELD INSTALLED
- - - - CLASS II VOLTAGE FIELD INSTALLED

09/05	Supersedes Form No.
New Form No.	
534,773W	

NOTE- The thermostat used may be electromechanical or electronic.
NOTE- Transformer in indoor unit supplies power (24 VAC) to the thermostat and outdoor unit controls.

COOLING:

- 1- Cooling demand initiates at Y1 in the thermostat.
- 2- 24VAC from indoor unit (Y1) energizes the TOC timed off control (if used) which energizes contactor K1 (provided S4 high pressure switch is closed).
- 3- K1-1 N.O. closes, energizing compressor (B1) and outdoor fan motor (B4).
- 4- Compressor (B1) and outdoor fan motor (B4) begin immediate operation..

END OF COOLING DEMAND:

- 5- Cooling demand is satisfied. Terminal Y1 is de-energized .
- 6- Compressor contactor K1 is de-energized.
- 7- K1-1 opens and compressor (B1) and outdoor fan motor (B4) are de-energized and stop immediately.